

LogiCORE IP AXI Video Direct Memory Access v5.04a

Product Guide

PG020 December 18, 2012

Table of Contents

SECTION I: SUMMARY

Chapter 1: Overview

Feature Summary	7
Applications	9
Unsupported Features	10
Licensing and Ordering Information	10

Chapter 2: Product Specification

Performance	11
Resource Utilization	14
Port Descriptions	19
Register Space	30

Chapter 3: Designing with the Core

General Design Guidelines	72
Clocking	72
Resets	75
Parameter Descriptions	75
Core Implementation	90
Programming Sequence	90
Triple Frame Buffer Example	113

SECTION II: VIVADO DESIGN SUITE

Chapter 4: Customizing and Generating the Core

Vivado IP Catalog GUI Options	118
Output Generation.....	125

Chapter 5: Constraining the Core

SECTION III: ISE DESIGN SUITE

Chapter 6: Customizing and Generating the Core

Generating the Core Using CORE Generator Tool	128
Generating the Core Using EDK.....	135
EDK pCore GUI	135
Output Generation.....	136

Chapter 7: Constraining the Core

Chapter 8: Detailed Example Design

SECTION IV: APPENDICES

Appendix A: HBlank and VBlank Periods for Standard Frames

Appendix B: Migrating

Appendix C: Debugging

Finding Help on Xilinx.com	145
Debug Tools	147
Hardware Debug	147

Appendix D: Additional Resources

Xilinx Resources	149
References	149
Technical Support	150
Ordering Information.....	150
Revision History	151
Notice of Disclaimer.....	152

SECTION I: SUMMARY

IP Facts

Overview

Product Specification

Designing with the Core

Introduction

The Advanced eXtensible Interface Video Direct Memory Access (AXI VDMA) core is a soft Xilinx Intellectual Property (IP) core providing high-bandwidth direct memory access between memory and AXI4-Stream video type target peripherals including peripherals which support AXI4-Stream Video Protocol as described in the Video IP: AXI Feature Adoption section of the *AXI Reference Guide* ([UG761](#)). Initialization, status, and management registers are accessed through an AXI4-Lite slave interface.

Features

- AXI4 Compliant
- Primary AXI4 Memory Map data width support of 32, 64, 128, 256, 512, and 1024 bits
- Primary AXI4-Stream data width support of multiples of 8 up to 1024 bits
- Register Direct Mode
- Optional independent Scatter Gather Direct Memory Access (DMA) support
- Optional Data Re-Alignment Engine
- Optional Genlock Synchronization
- Optional Line Buffers and Store-And-Forward
- Independent, asynchronous channel operation
- Dynamic clock frequency change of AXI4-Stream interface clocks
- Dynamic line buffer threshold
- Optional flush on frame sync
- Optional frame advancement on error
- Optional fsync crossbar, 32 fstores, and internal Genlock

LogiCORE™ IP Facts Table	
Core Specifics	
Supported Device Family ⁽¹⁾	Zynq™-7000 ⁽²⁾ , Virtex®-7, Kintex™-7, Artix™-7, Virtex-6, Spartan®-6
Supported User Interfaces	AXI4, AXI4-Lite, AXI4-Stream
Resources	See Table 2-4 and Table 2-5 .
Provided with Core	
Design Files ⁽³⁾	ISE®: VHDL Vivado™: VHDL
Example Design	XAPP739 , XAPP740 , XAPP741 , XAPP742
Test Bench	Not Provided
Constraints File	Not Provided
Simulation Model	Not Provided
Supported S/W Drivers ⁽⁴⁾	Standalone and Linux
Tested Design Flows⁽⁵⁾	
Design Entry	ISE Design Suite, Embedded Edition v14.4 ISE Design Suite v14.4 Vivado Design Suite v2012.4 ⁽⁶⁾
Simulation	ModelSim ISim, Vivado simulator
Synthesis	Xilinx Synthesis Technology (XST) Vivado Synthesis
Support	
Provided by Xilinx @ www.xilinx.com/support	

1. For a complete list of supported EDK derivative devices, see [Embedded Edition Derivative Device Support](#).
2. Supported in ISE Design Suite implementations only.
3. Contains few Verilog files. Top level is VHDL.
4. Standalone driver information can be found in the EDK or SDK installation directory.

See `xilinx_drivers.htm` in `<install_directory>/doc/usenglish`. Linux OS and driver support information is available from wiki.xilinx.com.
5. For the supported versions of the tools, see the [Xilinx Design Tools: Release Notes Guide](#).
6. Supports only 7 series devices.

Overview

Many video applications require frame buffers to handle frame rate changes, changes to the image dimensions (such as scaling). The AXI VDMA is designed to allow for efficient high-bandwidth access between AXI4-Stream video interface and AXI4 Memory Mapped interface.

Figure 1-1 illustrates the AXI VDMA Block Diagram.

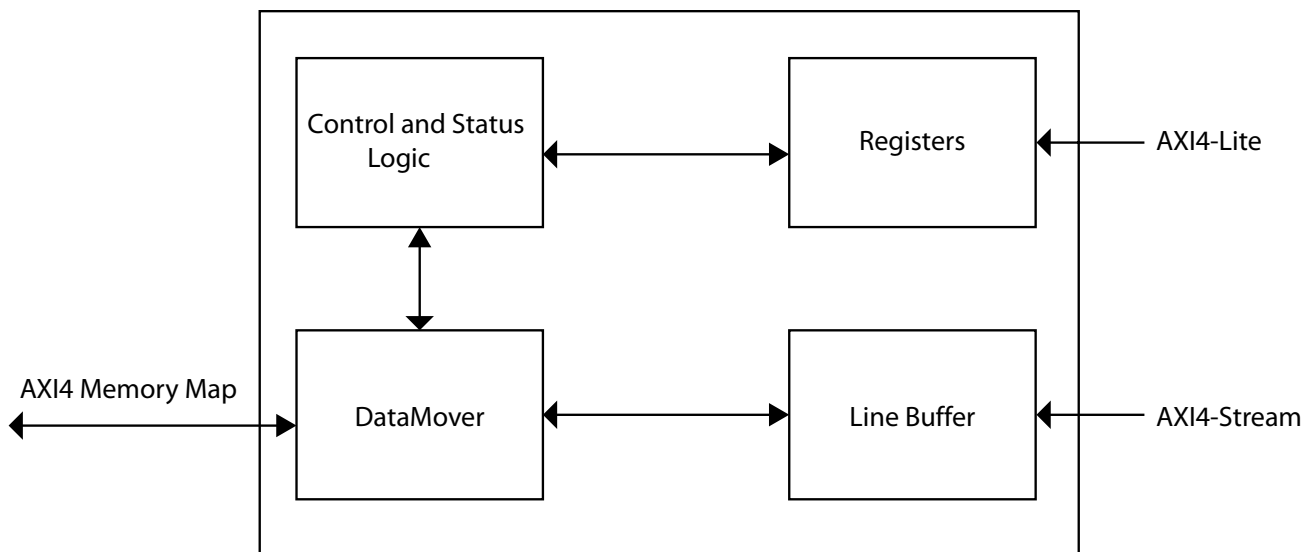

Figure 1-1: AXI4 Memory Map to AXI4-Stream Read

After registers are programmed through the AXI4-Lite interface, Control/ Status (Cntl/Sts) logic block generates appropriate commands to the Datamover to initiate Write and Read commands on the AXI4 Memory Map Master interface.

A configurable asynchronous line buffer is used to take care of frequency differences on both the Memory map and streaming side interfaces.

In the Write path, the AXI VDMA accepts frames on the AXI4-Stream Slave interface and writes it to system memory using the AXI4 Memory Map Master interface.

In the Read path, the AXI VDMA uses the AXI4 Memory Map Master interface for reading frames from system memory and outputs it on the AXI4-Stream Master interface.

Both write and read paths operate independently and in a full duplex like method. The AXI VDMA also provides an option to synchronize the incoming/outgoing frames with external synchronization signal.

Feature Summary

AXI4 Compliant

The AXI VDMA core is fully compliant with the AXI4 Memory Map interface, AXI4-Stream interface and AXI4-Lite interface. The AXI4-Stream also supports the Video Protocol as described in the "Video IP: AXI Feature Adoption" section of the *AXI Reference Guide* ([UG761](#)).

AXI4 Memory Map Data Width

The AXI VDMA core supports the primary AXI4 Memory Map data bus width of 32, 64, 128, 256, 512, and 1024 bits.

AXI4-Stream Data Width

The AXI VDMA core supports the primary AXI4-Stream data bus width of multiples of 8 bits up to 1024 bits. The AXI4-Stream data width must be less than or equal to the AXI4 Memory Map data width for the respective channel.

Register Direct Mode

The AXI VDMA core supports register direct mode in which the buffer start address and transfer size information are placed in the control register map along with the video-specific registers.

Scatter Gather Mode

The AXI VDMA core supports optional fetching and updating of transfer descriptors through the independent Scatter Gather AXI4-Memory Map bus. This allows descriptor placement to be in any memory-mapped location separate from data buffers. See [Scatter Gather Descriptor in Chapter 3](#) for details.

Data Realignment Engine

The AXI VDMA core supports the optional Data Realignment Engine (DRE). When the DRE is enabled, data reads/write can start from/to any start address byte offset, horizontal size and stride value. This feature is supported for the AXI4-Stream interface width up to 64 bits.

Genlock Synchronization

The AXI VDMA supports a mechanism to synchronize writing and reading of frames in the frame buffer through genlock synchronization. Each channel of the AXI VDMA can be designed to operate as either a Genlock Master/Slave or Dynamic Genlock Master/Slave. By using this feature, the master and slave are kept in sync by not allowing both to use the same buffer at the same time.

The AXI VDMA core supports an optional internal Genlock Bus. This eliminates the need for an external connection between the mm2s and s2mm channels. See [Genlock Synchronization in Chapter 3](#) for more details.

Line Buffers and Store and Forward

The AXI VDMA core supports an optional line buffer that can be utilized to prevent memory controller throttling from causing inner packet throttling on the stream interface. Line buffer parameters like empty and full signals are driven out of the AXI VDMA core for Video IP use.

The AXI VDMA core also supports the optional Store-And-Forward feature. On the read path (MM2S), this prevents the channel from requesting more read data than can be held in the Store-And-Forward buffer whereas on the write path (S2MM) Store and Forward option is always enabled as incoming data size is indeterminate.

Asynchronous Channels

The AXI VDMA core supports asynchronous clock domains for AXI4-Lite, AXI Scatter Gather (SG), S2MM AXI4-Stream interface, MM2S AXI4-Stream interface, S2MM AXI4 Memory Map interface and MM2S AXI4 Memory Map interface.

Frame Sync on TUSER0

The AXI VDMA supports an optional TUSER bus on both MM2S and S2MM AXIS interfaces with TUSER(0) being used for a Start of Frame (SOF) or external frame sync. When enabled (`C_MM2S_SOF_ENABLE=1`), MM2S channel will drive frame sync out on `m_axis_mm2s_tuser(0)`. When enabled (`C_S2MM_SOF_ENABLE=1`) and `S2MM_DMCCR[6:5] = 10`, S2MM channel will sync to frame sync in on `s_axis_s2mm_tuser(0)`. For more information, see the Video IP: AXI Feature Adoption section of the *AXI Reference Guide* ([UG761](#)).

Frame Sync Crossbar

This feature allows routing of various frame sync sources (`mm2s_fsync` or `s2mm_fsync` or `s_axis_s2mm_tuser(0)`) to both AXI VDMA channels. Control bits in DMACR (bits 5 and 6) of both channels select the respective channels frame sync source.

32 Frame Stores

AXI VDMA supports a maximum of 32 frame stores. `MM2S_REG_INDEX` and `S2MM_REG_INDEX` need to be set to access start addresses of 16 to 32 frame stores in read (MM2S) and write (S2MM) paths respectively. In this mode, `MM2S_REG_INDEX` and `S2MM_REG_INDEX` are added to create another set of register bank of 16 frame stores. This is done to keep it backward compatible with AXI VDMA previous versions.

Dynamic Clock Frequency Change on AXI4-Stream Interface

The AXI VDMA core allows you to change the primary datapath clocks dynamically to support different video resolutions without rebuilding the system.

Dynamic Line Buffer Threshold

This feature allows the almost empty and almost full threshold values to be dynamically changed by accessing new threshold registers.

Flush on Frame Sync

The flush on frame sync feature allows AXI VDMA to reset internal states and flush line buffer on frame sync for certain error conditions. This allows AXI VDMA to restart transfers at the beginning of the next new frame after DMA Internal error detection instead of halting the channel. This feature is added for both MM2S and S2MM channels independently.

Optional Frame Advancement on Error

When an error is detected in a particular frame, this optional feature allows the user to let the frame number advance on the next frame sync or not advance and reuse the errored frame's frame number.

Applications

The AXI VDMA core provides high-speed data movement between system memory and AXI4-Stream Video Protocol Video IP. See [Triple Frame Buffer Example in Chapter 3](#) for quick bring up of AXI VDMA.

Unsupported Features

The following AXI4 features are not supported by the AXI VDMA design.

- User signals on AXI4 Memory Map Interface
- Locked transfers
- Exclusive transfers
- FIXED and WRAP Burst transfers

Licensing and Ordering Information

This Xilinx LogiCORE™ IP module is provided at no additional cost with the Xilinx Vivado™ Design Suite and ISE® Design Suite tools under the terms of the [Xilinx End User License](#). Information about this and other Xilinx LogiCORE IP modules is available at the [Xilinx Intellectual Property](#) page. For information about pricing and availability of other Xilinx LogiCORE IP modules and tools, contact your [local Xilinx sales representative](#).

Product Specification

Performance

This section provides information about the performance of the AXI VDMA. Streaming side of AXI VDMA is looped back using shim logic. The block diagram shown in Figure 2-1 shows the configuration of the system that is used to report the frequency numbers in Table 2-1.

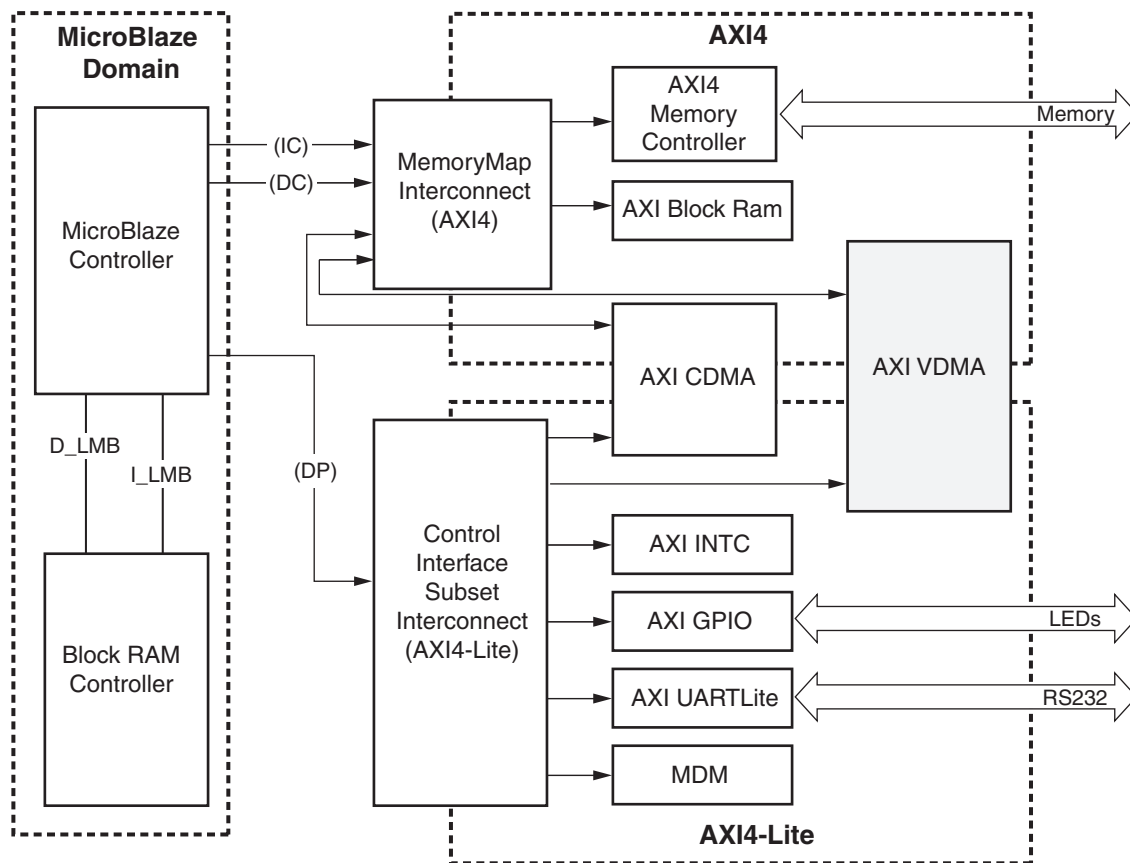

Figure 2-1: FPGA System Configuration Used for Generating System Performance Information

Maximum Frequencies

The target Field Programmable Gate Array (FPGA) was filled with logic to drive the Lookup Table (LUT) and block Random Access Memory (RAM) utilization to approximately 70% and the I/O utilization to approximately 80%. Using the default tool options and the slowest speed grade for the target FPGA, the resulting target FMAX numbers are shown in [Table 2-1](#).

Table 2-1: Maximum Frequencies

Family	Device	Speed Grade	Fmax ⁽¹⁾		
			AXI4	AXI4-Lite	AXI4-Stream
Spartan-6 ⁽²⁾	XC6SLX45T	-2	150 MHz	100 MHz	150 MHz
Virtex-6 ⁽³⁾	XC6VLX240T	-1	200 MHz	150 MHz	200 MHz
Virtex-7 ⁽³⁾	XC7VX485TFFG1761	-1	200 MHz	150 MHz	200 MHz
Kintex-7 ⁽³⁾	XC7K325TFFG900	-1	200 MHz	150 MHz	200 MHz
Zynq-7000 ⁽³⁾	XC7Z030FBG676	-1	200 MHz	150 MHz	200 MHz

Notes:

1. Fmax numbers represent both MM2S and S2MM channel clocks.
2. MicroBlaze™ processor frequency is 80 MHz.
3. MicroBlaze processor frequency is 150 MHz.
4. For better performance have AXI4 clock equal to greater than AXI4-Stream clock

Latency and Throughput

[Table 2-2](#) and [Table 2-3](#) describe the throughput and latency for the AXI VDMA. The tables provide performance information for a typical configuration. The throughput test consisted of eight video frames for each channel with each descriptor describing a 1000 lines at 1000 bytes per line per frame (~1 MB) and each channel operating simultaneously (full duplex). Throughput is measured from completion of descriptor fetches (DMACR.Idle = 1) to frame count interrupt assertion. Latency is measured on both the mm2s and s2mm path. [Table 2-3](#) shows the AXI VDMA core latency cycles only and does not include system dependent latency or throttling.

- AXI VDMA Configuration
 - C_USE_FSYNC = 0
 - C_NUM_FSTORES = 8
 - C_M_AXI_MM2S_DATA_WIDTH = 32 and C_M_AXI_S2MM_DATA_WIDTH = 32
 - C_M_AXIS_MM2S_TDATA_WIDTH = 32 and C_S_AXIS_S2MM_TDATA_WIDTH = 32
 - C_MM2S_MAX_BURST_LENGTH = 16 and C_S2MM_MAX_BURST_LENGTH = 16

- C_MM2S_GENLOCK_MODE = 0 and C_S2MM_GENLOCK_MODE = 0
- C_MM2S_LINEBUFFER_DEPTH = 0 and C_S2MM_LINEBUFFER_DEPTH = 0

Table 2-2: AXI VDMA Throughput (Synchronous Mode)

Channel	Clock Frequency (in MHz)	Frame Size (In Bytes)	Maximum Total Data Throughput (MBytes/sec)	Percent of Theoretical
MM2S	80	1 MB	287	89.68
	150	1 MB	539	89.83
S2MM	80	1 MB	290	90.6
	150	1 MB	542	90.3

Table 2-3: AXI VDMA Latency (Free Run Mode)

Description	Clocks
MM2S Channel	
mm2s_fsync_out to m_axi_mm2s_arvalid	14
m_axi_mm2s_rvalid to m_axis_mm2s_tvalid	4
last m_axis_mm2s_tlast to next mm2s_fsync_out	8
S2MM Channel	
s_axis_s2mm_tvalid to m_axi_s2mm_awvalid	14
m_axi_s2mm_awvalid and m_axi_s2mm_awready=1 to m_axi_s2mm_wvalid	2
last m_axi_s2mm_wlast to next s2mm_fsync_out	11

HSync Period

- HSync period is the time taken by the IP to process one line. Hsync period requirement for 1920x1080p frame = 14.81 us.
- HSync period achieved by AXI VDMA in 32-bit streaming data width (SOF - TLAST) = 9.59 us
- HSync period achieved by AXI VDMA in 24-bit streaming data width (SOF - TLAST) = 12.79 us. See [Appendix A, HBlank and VBlank Periods for Standard Frames](#) for more information.

Resource Utilization

Resources required for the AXI VDMA core have been estimated for Virtex®-7 and Kintex™-7, devices. These values were generated using Xilinx Vivado™ design tools 2012.4. The following parameters have been configured to static values throughout resource estimation.

- C_INCLUDE_MM2S_DRE = 0
- C_INCLUDE_S2MM_DRE = 0
- C_MM2S_LINEBUFFER_DEPTH = 2048
- C_S2MM_LINEBUFFER_DEPTH = 2048
- C_NUM_FSTORES = 3
- C_MM2S_GENLOCK_MODE = 1
- C_S2MM_GENLOCK_MODE = 0
- C_USE_FSYNC = 1
- C_INCLUDE_SG = 0
- C_ENABLE_VIDPRMTR_READS = 1
- C_PRMRY_IS_ACLK_ASYNC = 1
- C_INCLUDE_MM2S_SF = 1
- C_INCLUDE_S2MM_SF = 1
- C_FLUSH_ON_FSYNC = 1
- C_MM2S_SOF_ENABLE = 1
- C_S2MM_SOF_ENABLE = 1

[Table 2-4](#) shows resource estimation for Virtex-7 FPGAs and [Table 2-5](#) shows resource estimation for Kintex-7 FPGAs. [Table 2-6](#) and [Table 2-7](#) show resource estimation for Virtex-6 and Spartan®-6 respectively.

Note: Resource requirements for Artix™-7 and Zynq™-7000 devices are similar to Kintex-7 or Virtex-7 FPGAs as all 7 series devices are based on the same architecture.

Table 2-4: Resource Estimations for Virtex-7 FPGAs

C_INCLUDE_MM2S	C_INCLUDE_S2MM	C_M_AXI_MM2S_DATA_WIDTH	C_M_AXI_S2MM_DATA_WIDTH	C_M_AXIS_MM2S_TDATA_WIDTH	C_S_AXIS_S2MM_TDATA_WIDTH	C_MM2S_MAX_BURST_LENGTH	C_S2MM_MAX_BURST_LENGTH	Registers	LUTs	Slices	Block RAM
1	1	32	32	8	8	256	256	2871	3592	1330	6
1	1	64	64	16	16	256	256	2996	3782	1404	10
1	1	128	128	32	32	256	256	3202	4111	1465	18
1	1	256	256	32	32	128	128	3639	4756	1720	18
1	1	512	512	32	32	64	64	4563	6042	1934	18
1	1	512	512	64	64	64	64	4611	6220	2087	18
1	0	256	256	32	32	128	128	1315	1596	604	9
0	1	256	256	32	32	128	128	2431	3240	1182	9
1	1	256	256	256	256	128	128	3996	5867	1875	24
1	1	512	512	512	512	64	64	5268	8418	2926	32

Table 2-5: Resource Estimations for Kintex-7 FPGAs

C_INCLUDE_MM2S	C_INCLUDE_S2MM	C_M_AXI_MM2S_DATA_WIDTH	C_M_AXI_S2MM_DATA_WIDTH	C_M_AXIS_MM2S_TDATA_WIDTH	C_S_AXIS_S2MM_TDATA_WIDTH	C_MM2S_MAX_BURST_LENGTH	C_S2MM_MAX_BURST_LENGTH	Registers	LUTs	Slices	Block RAM
1	1	32	32	8	8	256	256	2869	3592	1270	6
1	1	64	64	16	16	256	256	2996	3782	1285	10
1	1	128	128	32	32	256	256	3201	4111	1414	18
1	1	256	256	32	32	128	128	3642	4756	1603	18
1	1	512	512	32	32	64	64	4565	6042	2057	18
1	1	512	512	64	64	64	64	4615	6220	2286	18
1	0	256	256	32	32	128	128	1315	1596	564	9
0	1	256	256	32	32	128	128	2432	3240	1033	9
1	1	256	256	256	256	128	128	3997	5867	2103	24
1	1	512	512	512	512	64	64	5271	8418	2783	32

Table 2-6: Resource Estimations for Virtex-6 FPGAs

C_INCLUDE_MM2S	C_INCLUDE_S2MM	C_M_AXI_MM2S_DATA_WIDTH	C_M_AXI_S2MM_DATA_WIDTH	C_M_AXIS_MM2S_TDATA_WIDTH	C_S_AXIS_S2MM_TDATA_WIDTH	C_MM2S_MAX_BURST_LENGTH	C_S2MM_MAX_BURST_LENGTH	Registers	LUTs	Slices	Block RAM
1	1	32	32	8	8	256	256	3533	3082	1096	6
1	1	64	64	16	16	256	256	3717	3161	1133	10
1	1	128	128	32	32	256	256	4112	3420	1311	18
1	1	256	256	32	32	128	128	4750	3550	1704	18
1	1	512	512	32	32	64	64	6014	3929	1740	18
1	1	512	512	64	64	64	64	6211	4630	1698	18
1	0	256	256	32	32	128	128	1584	1361	729	9
0	1	256	256	32	32	128	128	3180	2262	1143	9
1	1	256	256	256	256	128	128	5876	4007	1617	24
1	1	512	512	512	512	64	64	8426	4983	2214	32

Table 2-7: Resource Estimations for Spartan-6 FPGAs

C_INCLUDE_MM2S	C_INCLUDE_S2MM	C_M_AXI_MM2S_DATA_WIDTH	C_M_AXI_S2MM_DATA_WIDTH	C_M_AXIS_MM2S_TDATA_WIDTH	C_S_AXIS_S2MM_TDATA_WIDTH	C_MM2S_MAX_BURST_LENGTH	C_S2MM_MAX_BURST_LENGTH	Registers	LUTs	Slices	Block RAM
1	1	32	32	8	8	256	256	3567	3009	1233	11
1	1	64	64	16	16	256	256	3743	2928	1257	18
1	1	128	128	32	32	256	256	4135	3241	1377	32
1	1	256	256	32	32	128	128	4774	3645	1550	32
1	1	512	512	32	32	64	64	6058	3926	2081	32
1	1	512	512	64	64	64	64	6234	4014	2051	35
1	0	256	256	32	32	128	128	1600	1398	548	16
0	1	256	256	32	32	128	128	3192	2215	964	16
1	1	256	256	256	256	128	128	5898	3802	1885	46
1	1	512	512	512	512	64	64	8448	4702	2363	60

Port Descriptions

This section describes the details for each interface. In addition, detailed information about configuration and control registers is included.

The AXI VDMA signals are described in [Table 2-8](#).

Table 2-8: AXI VDMA I/O Signal Description

Signal Name	Interface	Signal Type	Init Status	Description
Clock, Reset and Interrupt Interface Signals				
Note: All aclk inputs must be tied to the same clock source when AXI VDMA is configured for synchronous clock mode (C_PRMRY_IS_ACLK_ASYNC=0).				
s_axi_lite_aclk	Clock	I		AXI VDMA AXI4-Lite interface clock
m_axi_sg_aclk	Clock	I		AXI VDMA Scatter Gather clock
m_axi_mm2s_aclk	Clock	I		AXI VDMA MM2S clock
m_axi_s2mm_aclk	Clock	I		AXI VDMA S2MM clock
m_axis_mm2s_aclk	Clock	I		AXI VDMA MM2S AXIS clock
s_axis_s2mm_aclk	Clock	I		AXI VDMA S2MM AXIS clock
axi_resetn	Reset	I		AXI VDMA Reset. Active-Low reset. When asserted low, resets entire AXI VDMA core. Must be synchronous to s_axi_lite_aclk and asserted for a minimum eight clock cycles.
mm2s_introut	Interrupt	O	0	Interrupt Out for Memory Map to Stream Channel
s2mm_introut	Interrupt	O	0	Interrupt Out for Stream to Memory Map Channel
Video Synchronization Interface Signals				
mm2s_fsync	Frame Sync	I		MM2S Frame Sync Input. When enabled, VDMA Operations begin on each falling edge of fsync. AXI VDMA expects this signal to be asserted for minimum of one m_axis_mm2s_aclk cycle. See C_USE_FSYNC in Parameter Descriptions for more details on different fsync modes.
mm2s_fsync_out	Frame Sync	O	0	MM2S Frame Sync Output. This signal asserts High for one m_axis_mm2s_aclk cycle with each frame boundary indicating start of frame on MM2S streaming interface.

Table 2-8: AXI VDMA I/O Signal Description (Cont'd)

Signal Name	Interface	Signal Type	Init Status	Description
mm2s_prmtr_update	Frame Sync	O	0	MM2S Parameter Update. This signal indicates that new mm2s video parameters take effect on next frame. This signal is asserted for one m_axis_mm2s_aclk cycle coincident with mm2s_fsync_out.
s2mm_fsync	Frame Sync	I		S2MM Frame Sync Input. When enabled, VDMA operations begin on each falling edge of fsync. AXI VDMA expects this signal to be asserted for a minimum of one s_axis_s2mm_aclk cycle. See C_USE_FSYNC in Parameter Descriptions for more details on different fsync modes.
s2mm_fsync_out	Frame Sync	O	0	S2MM Frame Sync Output. This signal asserts High for one s_axis_s2mm_aclk cycle with each frame boundary. Indicates when S2MM new frame data can be transferred to the S2MM channel by video IP.
s2mm_prmtr_update	Frame Sync	O	0	S2MM Parameter Update. This signal indicates that new s2mm video parameters take effect on next frame. This signal is asserted for one s_axis_s2mm_aclk cycle coincident with s2mm_fsync_out.

Table 2-8: AXI VDMA I/O Signal Description (Cont'd)

Signal Name	Interface	Signal Type	Init Status	Description
Genlock Interface Signals				
mm2s_frame_ptr_in((C_MM2S_GENLOCK_NUM_MASTERS*6)-1: 0)	Genlock	I		<p>MM2S Frame Pointer Input.</p> <ul style="list-style-type: none"> In Genlock Slave mode, it specifies the next frame for MM2S to operate on based on its FRMDLY setting. In Dynamic Genlock Slave mode, it specifies the next frame for MM2S to operate on. In Dynamic Genlock Master mode, it specifies the current frame that slave is operating on. <p>See Genlock Synchronization in Chapter 3 for more details on different Genlock modes.</p>
mm2s_frame_ptr_out(5:0)	Genlock	O	zeros	<p>MM2S Frame Pointer Output.</p> <ul style="list-style-type: none"> In Genlock Master mode, it specifies the next frame for the slave VDMA to operate on based on the slave VDMA FRMDLY setting. In Dynamic Genlock Master mode, it specifies the next frame for slave VDMA to operate on. In Dynamic Genlock Slave mode, it specifies the current frame that slave is operating on. <p>See Genlock Synchronization in Chapter 3 for more details on different Genlock modes.</p>
s2mm_frame_ptr_in((C_S2MM_GENLOCK_NUM_MASTERS*6)-1: 0)	Genlock	I		<p>S2MM Frame Pointer Input.</p> <ul style="list-style-type: none"> In Genlock Slave mode, it specifies the next frame for S2MM to operate on based on its FRMDLY setting. In Dynamic Genlock Slave mode, it specifies the next frame for S2MM to operate on. In Dynamic Genlock Master mode, it specifies the current frame that slave is operating on. <p>See Genlock Synchronization in Chapter 3 for more details on different Genlock modes.</p>

Table 2-8: AXI VDMA I/O Signal Description (Cont'd)

Signal Name	Interface	Signal Type	Init Status	Description
s2mm_frame_ptr_out(5:0)	Genlock	O	zeros	S2MM Frame Pointer Output. <ul style="list-style-type: none"> In Genlock Master mode, it specifies the next frame for the slave VDMA to operate on based on the slave VDMA FRMDLY setting. In Dynamic Genlock Master mode, it specifies the next frame for slave VDMA to operate on. In Dynamic Genlock Slave mode, it specifies the current frame that slave is operating on. See Genlock Synchronization in Chapter 3 for more details on different Genlock modes.
Line Buffer interface Signals				
mm2s_buffer_empty	LineBuffer	O	1	MM2S Line Buffer Empty. Indicates that the MM2S line buffer contains no stored data elements.
mm2s_buffer_almost_empty	LineBuffer	O	1	MM2S Line Buffer Almost Empty. Indicates that the MM2S line buffer has MM2S_THRESHOLD bytes or less stored. When mm2s_buffer_empty asserts, mm2s_buffer_almost_empty remains asserted.
s2mm_buffer_full	LineBuffer	O	0	S2MM Line Buffer Full. Indicates that the S2MM line buffer has no more room to store data elements.
s2mm_buffer_almost_full	LineBuffer	O	0	S2MM Line Buffer Almost Full. Indicates that the S2MM line buffer has S2MM_THRESHOLD bytes or more. When s2mm_buffer_full asserts, s2mm_buffer_almost_full remains asserted.

Table 2-8: AXI VDMA I/O Signal Description (Cont'd)

Signal Name	Interface	Signal Type	Init Status	Description
AXI4-Lite Interface Signals				
s_axi_lite_awvalid	S_AXI_LITE	I		AXI4-Lite Write Address Channel Write Address Valid. <ul style="list-style-type: none"> • 1 = Write address is valid. • 0 = Write address is not valid.
s_axi_lite_awready	S_AXI_LITE	O	0	AXI4-Lite Write Address Channel Write Address Ready. Indicates that DMA is ready to accept the write address. <ul style="list-style-type: none"> • 1 = Ready to accept address. • 0 = Not ready to accept address.
s_axi_lite_awaddr(31:0)	S_AXI_LITE	I		AXI4-Lite Write Address Bus.
s_axi_lite_wvalid	S_AXI_LITE	I		AXI4-Lite Write Data Channel Write Data Valid. <ul style="list-style-type: none"> • 1 = Write data is valid. • 0 = Write data is not valid.
s_axi_lite_wready	S_AXI_LITE	O	0	AXI4-Lite Write Data Channel Write Data Ready. Indicates DMA is ready to accept the write data. <ul style="list-style-type: none"> • 1 = Ready to accept data. • 0 = Not ready to accept data.
s_axi_lite_wdata(31:0)	S_AXI_LITE	I		AXI4-Lite Write Data Bus.
s_axi_lite_bresp(1:0)	S_AXI_LITE	O	Don't care	AXI4-Lite Write Response Channel. Indicates results of the write transfer. The AXI VDMA Lite interface always responds with OKAY. <ul style="list-style-type: none"> • 00b = OKAY — Normal access has been successful. • 01b = EXOKAY — Not supported. • 10b = SLVERR — Not supported. • 11b = DECERR — Not supported.
s_axi_lite_bvalid	S_AXI_LITE	O	0	AXI4-Lite Write Response Channel Response Valid. Indicates response is valid. <ul style="list-style-type: none"> • 1 = Response is valid. • 0 = Response is not valid.
s_axi_lite_bready	S_AXI_LITE	I		AXI4-Lite Write Response Channel Ready. Indicates target is ready to receive response. <ul style="list-style-type: none"> • 1 = Ready to receive response. • 0 = Not ready to receive response.
s_axi_lite_arvalid	S_AXI_LITE	I		AXI4-Lite Read Address Channel Read Address Valid. <ul style="list-style-type: none"> • 1 = Read address is valid. • 0 = Read address is not valid.

Table 2-8: AXI VDMA I/O Signal Description (Cont'd)

Signal Name	Interface	Signal Type	Init Status	Description
s_axi_lite_arready	S_AXI_LITE	O	0	AXI4-Lite Read Address Channel Read Address Ready. Indicates DMA is ready to accept the read address. <ul style="list-style-type: none"> • 1 = Ready to accept address. • 0 = Not ready to accept address.
s_axi_lite_araddr(31:0)	S_AXI_LITE	I		AXI4-Lite Read Address Bus.
s_axi_lite_rvalid	S_AXI_LITE	O	0	AXI4-Lite Read Data Channel Read Data Valid. <ul style="list-style-type: none"> • 1 = Read data is valid. • 0 = Read data is not valid.
s_axi_lite_rready	S_AXI_LITE	I		AXI4-Lite Read Data Channel Read Data Ready. Indicates target is ready to accept the read data. <ul style="list-style-type: none"> • 1 = Ready to accept data. • 0 = Not ready to accept data.
s_axi_lite_rdata(31:0)	S_AXI_LITE	O	Don't care	AXI4-Lite Read Data Bus
s_axi_lite_rresp(1:0)	S_AXI_LITE	O	Don't care	AXI4-Lite Read Response Channel Response. Indicates results of the read transfer. The AXI VDMA Lite interface always responds with OKAY. <ul style="list-style-type: none"> • 00b = OKAY — Normal access has been successful. • 01b = EXOKAY — Not supported. • 10b = SLVERR — Not supported. • 11b = DECERR — Not supported.
MM2S Memory Map Read Interface Signals				
m_axi_mm2s_araddr (C_M_AXI_MM2S_ADDR_WIDTH-1: 0)	M_AXI_MM2S	O	Don't care	Read Address Channel Address Bus
m_axi_mm2s_arlen(7:0)	M_AXI_MM2S	O	Don't care	Read Address Channel Burst Length. In data beats - 1.
m_axi_mm2s_arsize(2:0)	M_AXI_MM2S	O	Don't care	Read Address Channel Burst Size. Indicates width of burst transfer. <ul style="list-style-type: none"> • 000b = 1 byte (8-bit wide burst). • 001b = 2 bytes (16-bit wide burst). • 010b = 4 bytes (32-bit wide burst). • 011b = 8 bytes (64-bit wide burst). • 100b = 16 bytes (128-bit wide burst). • 101b = 32 bytes (256-bit wide burst). • 110b = 64 bytes (512 bit wide burst). • 111b = 128 bytes (1024 bit wide burst).

Table 2-8: AXI VDMA I/O Signal Description (Cont'd)

Signal Name	Interface	Signal Type	Init Status	Description
m_axi_mm2s_arburst(1:0)	M_AXI_MM2S	O	Don't care	Read Address Channel Burst Type. Indicates type burst. <ul style="list-style-type: none"> • 00b = FIXED — Not supported. • 01b = INCR — Incrementing address. • 10b = WRAP — Not supported. • 11b = Reserved.
m_axi_mm2s_arprot(2:0)	M_AXI_MM2S	O	000b	Read Address Channel Protection. Always driven with a constant output of 000b along with m_axi_mm2s_arvalid.
m_axi_mm2s_arcache(3:0)	M_AXI_MM2S	O	0011b	Read Address Channel Cache. Always driven with a constant output of 0011b along with m_axi_mm2s_arvalid.
m_axi_mm2s_arvalid	M_AXI_MM2S	O	0	Read Address Channel Read Address Valid. Indicates m_axi_mm2s_araddr is valid. <ul style="list-style-type: none"> • 1 = Read address is valid. • 0 = Read address is not valid.
m_axi_mm2s_arready	M_AXI_MM2S	I		Read Address Channel Read Address Ready. Indicates target is ready to accept the read address. <ul style="list-style-type: none"> • 1 = Target ready to accept address. • 0 = Target not ready to accept address.
m_axi_mm2s_rdata (C_M_AXI_MM2S_DATA_WIDTH-1: 0)	M_AXI_MM2S	I		Read Data Channel Read Data.
m_axi_mm2s_rresp(1:0)	M_AXI_MM2S	I		Read Data Channel Response. Indicates results of the read transfer. <ul style="list-style-type: none"> • 00b = OKAY — Normal access has been successful. • 01b = EXOKAY — Not supported. • 10b = SLVERR — Slave returned error on transfer. • 11b = DECERR — Decode error, transfer targeted unmapped address.
m_axi_mm2s_rlast	M_AXI_MM2S	I		Read Data Channel Last. Indicates the last data beat of a burst transfer. <ul style="list-style-type: none"> • 1 = Last data beat. • 0 = Not last data beat.
m_axi_mm2s_rvalid	M_AXI_MM2S	I		Read Data Channel Data Valid. Indicates m_axi_mm2s_rdata is valid. <ul style="list-style-type: none"> • 1 = Valid read data. • 0 = Not valid read data.

Table 2-8: AXI VDMA I/O Signal Description (Cont'd)

Signal Name	Interface	Signal Type	Init Status	Description
m_axi_mm2s_rready	M_AXI_MM2S	O		Read Data Channel Ready. Indicates the read channel is ready to accept read data. <ul style="list-style-type: none"> • 1 = Ready. • 0 = Not ready.
MM2S Master Stream Interface Signals				
mm2s_prmry_reset_out_n	M_AXIS_MM2S	O	0	Primary MM2S Reset Out.
m_axis_mm2s_tdata (C_M_AXIS_MM2S_TDATA_WIDTH-1: 0)	M_AXIS_MM2S	O	Don't care	AXI4-Stream Data Out.
m_axis_mm2s_tkeep (C_M_AXIS_MM2S_TDATA_WIDTH/8-1: 0)	M_AXIS_MM2S	O	Don't care	AXI4-Stream Write Keep. Indicates valid bytes on stream data. (For most use cases, all bytes will be valid.) <ul style="list-style-type: none"> • 1 = Byte is valid • 0 = Byte is not valid
m_axis_mm2s_tuser[C_M_AXIS_MM2S_TUSER_BITS-1:0]	M_AXIS_MM2S	O	Don't care	AXI4-Stream user bits. tuser(0) drives out mm2s start of frame (SOF). This signal is asserted for one clock period.
m_axis_mm2s_tvalid	M_AXIS_MM2S	O	0	AXI4-Stream Valid Out. Indicates stream data bus, m_axis_mm2s_tdata, is valid <ul style="list-style-type: none"> • 1 = Write data is valid. • 0 = Write data is not valid.
m_axis_mm2s_tready	M_AXIS_MM2S	I		AXI4-Stream Ready. Indicates to S2MM channel target is ready to receive stream data. <ul style="list-style-type: none"> • 1 = Ready to receive data. • 0 = Not ready to receive data.
m_axis_mm2s_tlast	M_AXIS_MM2S	O	Don't care	AXI4-Stream Last. Indicates last data beat of stream data. <ul style="list-style-type: none"> • 1 = Last data beat. • 0 = Not last data beat. See the Video IP: AXI Feature Adoption section of the <i>AXI Reference Guide</i> (UG76) for additional information.
S2MM Memory Map Write Interface Signals				
m_axi_s2mm_awaddr (C_M_AXI_S2MM_ADDR_WIDTH-1: 0)	M_AXI_S2MM	O	Don't care	Write Address Channel Address Bus.
m_axi_s2mm_awlen(7: 0)	M_AXI_S2MM	O	Don't care	Write Address Channel Burst Length. In data beats - 1.

Table 2-8: AXI VDMA I/O Signal Description (Cont'd)

Signal Name	Interface	Signal Type	Init Status	Description
m_axi_s2mm_awsiz(2: 0)	M_AXI_S2MM	O	Don't care	Write Address Channel Burst Size. Indicates width of burst transfer. <ul style="list-style-type: none"> • 000b = 1 byte (8 bit wide burst). • 001b = 2 bytes (16 bit wide burst). • 010b = 4 bytes (32 bit wide burst). • 011b = 8 bytes (64 bit wide burst). • 100b = 16 bytes (128 bit wide burst). • 101b = 32 bytes (256 bit wide burst). • 110b = 64 bytes (512 bit wide burst). • 111b = 128 bytes (1024 bit wide burst).
m_axi_s2mm_awburst(1:0)	M_AXI_S2MM	O	Don't care	Write Address Channel Burst Type. Indicates type burst. <ul style="list-style-type: none"> • 00b = FIXED — Not supported. • 01b = INCR — Incrementing address. • 10b = WRAP — Not supported. • 11b = Reserved.
m_axi_s2mm_awprot(2:0)	M_AXI_S2MM	O	000b	Write Address Channel Protection. Always driven with a constant output of 000b along with m_axi_s2mm_awvalid.
m_axi_s2mm_awcache(3:0)	M_AXI_S2MM	O	0011b	Write Address Channel Cache. Always driven with a constant output of 0011b along with m_axi_s2mm_awvalid.
m_axi_s2mm_awvalid	M_AXI_S2MM	O	0	Write Address Channel Write Address Valid. Indicates if m_axi_s2mm_awaddr is valid. <ul style="list-style-type: none"> • 1 = Write Address is valid. • 0 = Write Address is not valid.
m_axi_s2mm_awready	M_AXI_S2MM	I		Write Address Channel Write Address Ready. Indicates target is ready to accept the write address. <ul style="list-style-type: none"> • 1 = Target read to accept address. • 0 = Target not ready to accept address.
m_axi_s2mm_wdata (C_M_AXI_S2MM_DATA_WIDTH-1: 0)	M_AXI_S2MM	O	Don't care	Write Data Channel Write Data Bus.
m_axi_s2mm_wstrb (C_M_AXI_S2MM_DATA_WIDTH/8 - 1: 0)	M_AXI_S2MM	O	Don't care	Write Data Channel Write Strobe Bus. Indicates which bytes are valid in the write data bus. This value is passed from the stream side strobe bus.
m_axi_s2mm_wlast	M_AXI_S2MM	O	Don't care	Write Data Channel Last. Indicates the last data beat of a burst transfer. <ul style="list-style-type: none"> • 1 = Last data beat. • 0 = Not last data beat.

Table 2-8: AXI VDMA I/O Signal Description (Cont'd)

Signal Name	Interface	Signal Type	Init Status	Description
m_axi_s2mm_wvalid	M_AXI_S2MM	O	0	Write Data Channel Data Valid. Indicates m_axi_s2mm_wdata is valid. <ul style="list-style-type: none"> • 1 = Valid write data. • 0 = Not valid write data.
m_axi_s2mm_wready	M_AXI_S2MM	I		Write Data Channel Ready. Indicates the write channel target is ready to accept write data. <ul style="list-style-type: none"> • 1 = Target is ready • 0 = Target is not ready
m_axi_s2mm_bresp(1:0)	M_AXI_S2MM	I		Write Response Channel Response. Indicates results of the write transfer. <ul style="list-style-type: none"> • 00b = OKAY — Normal access has been successful. • 01b = EXOKAY — Not supported. • 10b = SLVERR — Slave returned error on transfer. • 11b = DECERR — Decode error, transfer targeted unmapped address.
m_axi_s2mm_bvalid	M_AXI_S2MM	I		Write Response Channel Response Valid. Indicates response, m_axi_s2mm_bresp, is valid. <ul style="list-style-type: none"> • 1 = Response is valid. • 0 = Response is not valid.
m_axi_s2mm_bready	M_AXI_S2MM	O	0	Write Response Channel Ready. Indicates MM2S write channel is ready to receive response. <ul style="list-style-type: none"> • 1 = Ready to receive response. • 0 = Not ready to receive response.
S2MM Slave Stream Interface Signals				
s2mm_prmry_reset_out_n	M_AXIS_S2MM	O	O	Primary S2MM Reset Out
s_axis_s2mm_tdata (C_S_AXIS_S2MM_TDATA_WIDTH-1: 0)	S_AXIS_S2MM	I		AXI4-Stream Data In
s_axis_s2mm_tkeep (C_S_AXIS_S2MM_TDATA_WIDTH/8-1: 0)	S_AXIS_S2MM	I		AXI4-Stream Write Keep. Indicates valid bytes on stream data. (For most use cases, all bytes are valid.) It needs to be tied High if stream master does not have this signal. <ul style="list-style-type: none"> • 1 = Byte is valid • 0 = Byte is not valid
s_axis_s2mm_tuser[C_S_AXIS_S2MM_TUSER_BITS-1: 0]	M_AXIS_S2MM	I	Don't care	AXI4-Stream user bits. The signal tuser(0) receives in s2mm start of frame (SOF). AXI VDMA expects this signal to be asserted for one clock period only.

Table 2-8: AXI VDMA I/O Signal Description (Cont'd)

Signal Name	Interface	Signal Type	Init Status	Description
s_axis_s2mm_tvalid	S_AXIS_S2MM	I		AXI4-Stream Valid In. Indicates stream data bus, s_axis_s2mm_tdata, is valid. <ul style="list-style-type: none"> • 1 = Write data is valid. • 0 = Write data is not valid.
s_axis_s2mm_tready	S_AXIS_S2MM	O	0	AXI4-Stream Ready. Indicates MM2S channel stream interface ready to receive stream data. <ul style="list-style-type: none"> • 1 = Ready to receive data. • 0 = Not ready to receive data.
s_axis_s2mm_tlast	S_AXIS_S2MM	I		AXI4-Stream Last. Indicates last data beat of stream data. <ul style="list-style-type: none"> • 1 = Last data beat. • 0 = Not last data beat. For additional information, see the Video IP: AXI Feature Adoption section of the UG76 <i>AXI Reference Guide</i> .
Scatter Gather Memory Map Read Interface Signals				
m_axi_sg_araddr (C_M_AXI_SG_ADDR_WIDTH-1: 0)	M_AXI_SG	O	Don't care	Scatter Gather Read Address Channel Address Bus.
m_axi_sg_arlen(7: 0)	M_AXI_SG	O	Don't care	Scatter Gather Read Address Channel Burst Length. Length in data beats - 1.
m_axi_sg_arsize(2: 0)	M_AXI_SG	O	Don't care	Scatter Gather Read Address Channel Burst Size. Indicates width of burst transfer. 010b = 4 bytes (32 bit wide burst). Other values not supported
m_axi_sg_arburst(1:0)	M_AXI_SG	O	Don't care	Scatter Gather Read Address Channel Burst Type. Indicates type burst. <ul style="list-style-type: none"> • 00b = FIXED — Not supported. • 01b = INCR — Incrementing address. • 10b = WRAP — Not supported. • 11b = Reserved.
m_axi_sg_arprot(2:0)	M_AXI_SG	O	000b	Scatter Gather Read Address Channel Protection. Always driven with a constant output of 000b along with m_axi_sg_arvalid.
m_axi_sg_arcache(3:0)	M_AXI_SG	O	0011b	Scatter Gather Read Address Channel Cache. Always driven with a constant output of 0011b along with m_axi_sg_arvalid.
m_axi_sg_arvalid	M_AXI_SG	O	0	Scatter Gather Read Address Channel Read Address Valid. Indicates if m_axi_sg_araddr is valid. <ul style="list-style-type: none"> • 1 = Read Address is valid. • 0 = Read Address is not valid.

Table 2-8: AXI VDMA I/O Signal Description (Cont'd)

Signal Name	Interface	Signal Type	Init Status	Description
m_axi_sg_arready	M_AXI_SG	I		Scatter Gather Read Address Channel Read Address Ready. Indicates target is ready to accept the read address. <ul style="list-style-type: none"> • 1 = Target ready to accept address. • 0 = Target not ready to accept address.
m_axi_sg_rdata (C_M_AXI_SG_DATA_WIDTH-1: 0)	M_AXI_SG	I		Scatter Gather Read Data Channel Read Data.
m_axi_sg_rresp(1:0)	M_AXI_SG	I		Scatter Gather Read Data Channel Response. Indicates results of the read transfer. <ul style="list-style-type: none"> • 00b = OKAY — Normal access has been successful. • 01b = EXOKAY — Not supported. • 10b = SLVERR — Slave returned error on transfer. • 11b = DECERR — Decode error, transfer targeted unmapped address.
m_axi_sg_rlast	M_AXI_SG	I		Scatter Gather Read Data Channel Last. Indicates the last data beat of a burst transfer. <ul style="list-style-type: none"> • 1 = Last data beat. • 0 = Not last data beat.
m_axi_sg_rvalid	M_AXI_SG	I		Scatter Gather Read Data Channel Data Valid. Indicates m_sg_aximry_rdata is valid. <ul style="list-style-type: none"> • 1 = Valid read data. • 0 = Not valid read data.
m_axi_sg_rready	M_AXI_SG	O	0	Scatter Gather Read Data Channel Ready. Indicates the read channel is ready to accept read data. <ul style="list-style-type: none"> • 1 = Is ready. • 0 = Is not ready.

Register Space

The AXI VDMA core register space for Register Direct mode is shown in [Table 2-9](#) and for Scatter Gather Mode is shown in [Table 2-10](#). The AXI VDMA Registers are memory-mapped into non-cacheable memory space. This memory space must be aligned on a AXI word (32-bit) boundary.

Endianess

All registers are in Little Endian format, as shown in Figure 2-2.

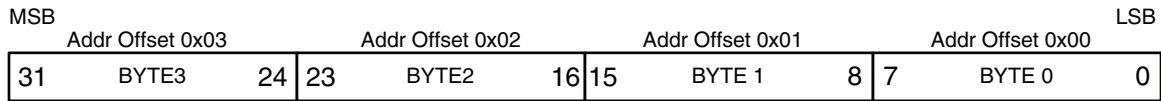

Figure 2-2: 32-bit Little Endian Example

AXI VDMA Register Address Mapping For Register Direct Mode

Table 2-9: Register Address Mapping for Register Direct Mode

Address Space Offset ⁽¹⁾	Name	Description
00h	MM2S_DMACR	MM2S DMA Control Register
04h	MM2S_DMASR	MM2S DMA Status Register
08 to 10h	Reserved	N/A
14h	MM2S_REG_INDEX	MM2S Register Index
18h	MM2S_FRMSTORE	MM2S Frame Store Register
1Ch	MM2S_THRESHOLD	MM2S Line Buffer Threshold Register
20h	Reserved	N/A
24h	FRMPTR_STS	MM2S and S2MM Current Frame Pointer Status
28h	PARK_PTR_REG	MM2S and S2MM Park Pointer Register
2Ch	VDMA_VERSION	Video DMA Version Register
30h	S2MM_DMACR	S2MM DMA Control Register
34h	S2MM_DMASR	S2MM DMA Status Register
38h to 40h	Reserved	N/A
44h	S2MM_REG_INDEX	S2MM Register Index
48h	S2MM_FRMSTORE	S2MM Frame Store Register
4Ch	S2MM_THRESHOLD	S2MM Line Buffer Threshold Register
50h	MM2S_VSIZE ⁽³⁾	MM2S Vertical Size Register
54h	MM2S_HSIZE ⁽³⁾	MM2S Horizontal Size Register
58h	MM2S_FRMDLY_STRIDE ⁽³⁾	MM2S Frame Delay and Stride Register
5Ch	MM2S_START_ADDRESS1 ⁽³⁾	MM2S Start Address 1
60h	MM2S_START_ADDRESS2 ^{(2) (3)}	MM2S Start Address 2
64h	MM2S_START_ADDRESS3 ^{(2) (3)}	MM2S Start Address 3
68h	MM2S_START_ADDRESS4 ^{(2) (3)}	MM2S Start Address 4
6Ch	MM2S_START_ADDRESS5 ⁽²⁾⁽³⁾	MM2S Start Address 5
70h	MM2S_START_ADDRESS6 ^{(2) (3)}	MM2S Start Address 6

Table 2-9: Register Address Mapping for Register Direct Mode (Cont'd)

Address Space Offset ⁽¹⁾	Name	Description
74h	MM2S_START_ADDRESS7 ^{(2) (3)}	MM2S Start Address 7
78h	MM2S_START_ADDRESS8 ^{(2) (3)}	MM2S Start Address 8
7Ch	MM2S_START_ADDRESS9 ^{(2) (3)}	MM2S Start Address 9
80h	MM2S_START_ADDRESS10 ^{(2) (3)}	MM2S Start Address 10
84h	MM2S_START_ADDRESS11 ^{(2) (3)}	MM2S Start Address 11
88h	MM2S_START_ADDRESS12 ^{(2) (3)}	MM2S Start Address 12
8Ch	MM2S_START_ADDRESS13 ^{(2) (3)}	MM2S Start Address 13
90h	MM2S_START_ADDRESS14 ^{(2) (3)}	MM2S Start Address 14
94h	MM2S_START_ADDRESS15 ^{(2) (3)}	MM2S Start Address 15
98h	MM2S_START_ADDRESS16 ^{(2) (3)}	MM2S Start Address 16
9Ch	Reserved	N/A
A0h	S2MM_VSIZE ⁽³⁾	S2MM Vertical Size Register
A4h	S2MM_HSIZE ⁽³⁾	S2MM Horizontal Size Register
A8h	S2MM_FRMDLY_STRIDE ⁽³⁾	S2MM Frame Delay and Stride Register
ACh	S2MM_START_ADDRESS1 ⁽³⁾	S2MM Start Address 1
B0h	S2MM_START_ADDRESS2 ^{(2) (3)}	S2MM Start Address 2
B4h	S2MM_START_ADDRESS3 ^{(2) (3)}	S2MM Start Address 3
B8h	S2MM_START_ADDRESS4 ^{(2) (3)}	S2MM Start Address 4
BCh	S2MM_START_ADDRESS5 ^{(2) (3)}	S2MM Start Address 5
C0h	S2MM_START_ADDRESS6 ^{(2) (3)}	S2MM Start Address 6
C4h	S2MM_START_ADDRESS7 ^{(2) (3)}	S2MM Start Address 7
C8h	S2MM_START_ADDRESS8 ^{(2) (3)}	S2MM Start Address 8
CCh	S2MM_START_ADDRESS9 ⁽²⁾⁽³⁾	S2MM Start Address 9
D0h	S2MM_START_ADDRESS10 ^{(2) (3)}	S2MM Start Address 10
D4h	S2MM_START_ADDRESS11 ⁽²⁾⁽³⁾	S2MM Start Address 11
D8h	S2MM_START_ADDRESS12 ^{(2) (3)}	S2MM Start Address 12
DCh	S2MM_START_ADDRESS13 ^{(2) (3)}	S2MM Start Address 13
E0h	S2MM_START_ADDRESS14 ⁽²⁾⁽³⁾	S2MM Start Address 14
E4h	S2MM_START_ADDRESS15 ^{(2) (3)}	S2MM Start Address 15
E8h	S2MM_START_ADDRESS16 ^{(2) (3)}	S2MM Start Address 16
ECh	Reserved	N/A
F0h	S2MM_HSIZE_STATUS	S2MM hsize status Register

Table 2-9: Register Address Mapping for Register Direct Mode (Cont'd)

Address Space Offset ⁽¹⁾	Name	Description
F4h	S2MM_VSIZE_STATUS	S2MM vsize status Register

1. Address Space Offset is relative to C_BASEADDR assignment.
2. Start Addresses 2 to 32 for MM2S and S2MM depend on C_NUM_FSTORES parameter. Start address registers greater than C_NUM_FSTORES setting are reserved. Only MM2S_FRMSTORE or S2MM_FRMSTORE start address registers for the respective channel are used for transfers. See the MM2S_REG_INDEX and S2MM_REG_INDEX register definitions for accessing 32 start address registers.
3. Video parameter and start address registers are Read/Writable when the video parameter reads are enabled. (C_ENABLE_VIDPRMTR_READS=1) and are Write Only when the video parameter reads are disabled. (C_ENABLE_VIDPRMTR_READS=0).

AXI VDMA Register Address Mapping For Scatter Gather Mode

Table 2-10: Register Address Mapping for Scatter Gather Mode

Address Space Offset ^a	Name	Description
00h	MM2S_DMOCR	MM2S DMA Control Register
04h	MM2S_DMASR	MM2S DMA Status Register
08h	MM2S_CURDESC	MM2S Current Descriptor Pointer
0Ch	Reserved	N/A
10h	MM2S_TAILDESC	MM2S Tail Descriptor Pointer
14h	Reserved	N/A
18h	MM2S_FRMSTORE	MM2S Frame Store Register
1Ch	MM2S_THRESHOLD	MM2S Line Buffer Threshold Register
20h	Reserved	N/A
24h	FRMPTR_STS	MM2S and S2MM Current Frame Pointer Status
28h	PARK_PTR_REG	MM2S and S2MM Park Pointer Register
2Ch	VDMA_VERSION	Video DMA Version Register
30h	S2MM_DMOCR	S2MM DMA Control Register
34h	S2MM_DMASR	S2MM DMA Status Register
38h	S2MM_CURDESC	S2MM Current Descriptor Pointer
3Ch	Reserved	N/A
40h	S2MM_TAILDESC	S2MM Tail Descriptor Pointer
44h	Reserved	N/A
48h	S2MM_FRMSTORE	S2MM Frame Store Register
4Ch	S2MM_THRESHOLD	S2MM Line Buffer Threshold Register
50h - EFh	Reserved	N/A
F0h	S2MM_HSIZE_STATUS	S2MM hsize status Register
F4h	S2MM_VSIZE_STATUS	S2MM vsize status Register

- a. Address Space Offset is relative to C_BASEADDR assignment. C_BASEADDR is defined in AXI VDMA mpd file and set by XPS.

Memory Map to Stream Register Details

Register Access Type Description

- RO = Read Only. Writing has no effect
- R/W = Read and Write Accessible
- R/WC = Read / Write to Clear

MM2S_DMCCR (MM2S DMA Control Register – Offset 00h) (C_INCLUDE_SG = 1/0)

This register provides control for the Memory Map to Stream DMA Channel for both Scatter Gather mode and Register Direct mode.

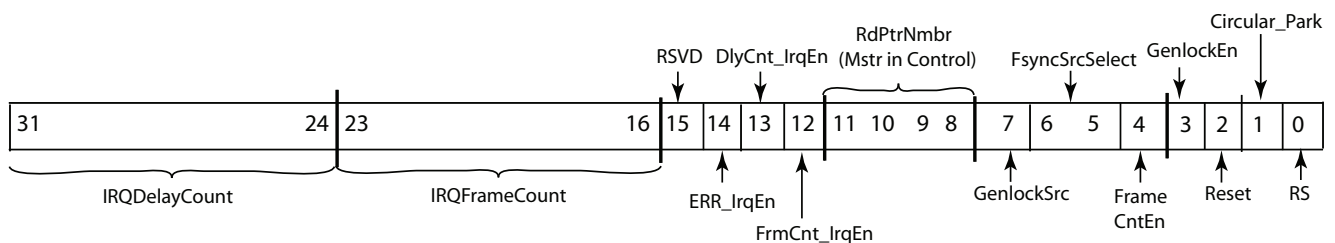

Figure 2-3: MM2S DMCCR Register

Table 2-11: MM2S_DMACR Register Details

Bits	Field Name	Default Value	Access Type	Description
31 downto 24	IRQDelayCount	00h	R/W	<p>This value is used for setting the interrupt delay count value. The delay count interrupt is a mechanism for causing the DMA engine to generate an interrupt after the delay period has expired. Timer begins counting either upon receipt of frame sync (if C_USE_FSYNC=1,2,3) or completion of vsize lines (if C_USE_FSYNC=0). It resets with subsequent start of packet (m_axis_mm2s_tvalid) assertion. When a value different than the current IRQDelayCount is written to this field, the internal delay counter is reset to the new value.</p> <p>Setting this value to zero disables the delay counter interrupt.</p>
23 downto 16	IRQFrameCount	01h	R/W	<p>This value is used for setting the interrupt threshold. When frame transfer interrupt events occur, an internal counter counts down from the Interrupt Frame Count setting. When the count reaches zero, an interrupt out is generated by the VDMA engine. When a value different than the current IRQFrameCount is written to this field, the internal frame counter is reset to the new value.</p> <p>The minimum setting for the count is 0x01. A write of 0x00 to this register sets the count to 0x01.</p> <p>When DMACR.FrameCntEn = 1, this value determines the number of frame buffers to process.</p>
15	Reserved	0	RO	Writing to this bit has no effect and it is always read as zeros.
14	Err_IrqEn	0	R/W	<p>Interrupt on Error Interrupt Enable. When set to 1, allows DMASR.Err_Irq to generate an interrupt out.</p> <p>0 = Error Interrupt disabled 1 = Error Interrupt enabled</p>
13	DlyCnt_IrqEn	0	R/W	<p>Interrupt on Delay Count Interrupt Enable. When set to 1, allows DMASR.DlyCnt_Irq to generate an interrupt out.</p> <p>0 = Delay Count Interrupt disabled 1 = Delay Count Interrupt enabled</p>
12	FrmCnt_IrqEn	0	R/W	<p>Frame Count Complete Interrupt Enable. When set to 1, allows DMASR.FrmCnt_Irq to generate an interrupt out when IRQFrameCount value reaches zero.</p> <p>0 = Frame Count Interrupt disabled 1 = Frame Count Interrupt enabled</p>

Table 2-11: MM2S_DMACR Register Details (Cont'd)

Bits	Field Name	Default Value	Access Type	Description
11 downto 8	RdPntrNum	zeros	R/W	<p>Indicates the master in control when MM2S channel is configured for Genlock slave/Dynamic Genlock Master/Dynamic Genlock Slave (C_MM2S_GENLOCK_MODE = 1,2,3) or reserved otherwise.</p> <p>0000b = Controlling entity is Entity 1 0001b = Controller entity is Entity 2 0010b = Controller entity is Entity 3 and so on.</p> <p>Maximum valid RdPntrNum is C_MM2S_GENLOCK_NUM_MASTER - 1. Setting to a value greater than C_MM2S_GENLOCK_NUM_MASTER - 1 has undefined results. See Genlock Synchronization in Chapter 3 for more details on different Genlock modes.</p>
7	GenlockSrc	0	R/W	<p>Selects internal or external genlock bus.</p> <ul style="list-style-type: none"> 0 = External Genlock 1 = Internal Genlock <p>This bit has meaning only:</p> <ul style="list-style-type: none"> if both VDMA channels are enabled AND if one VDMA channel is configured as Genlock Master then the other VDMA channel <i>must</i> be configured as Genlock Slave OR if one VDMA channel is configured as Dynamic Genlock Master then the other VDMA channel <i>must</i> be configured as Dynamic Genlock Slave AND if C_INCLUDE_INTERNAL_GENLOCK = 1 <p>See Genlock Synchronization in Chapter 3 for more details on different Genlock modes.</p>
6 downto 5	FsyncSrcSelect	00	R/W	<p>Selects the frame sync source for the MM2S channel. The frame sync source is selected as follows:</p> <ul style="list-style-type: none"> 00 = mm2s_fsync 01 = s2mm_fsync 10 = reserved 11 = reserved <p>Note: Frame Sync Source Select is only valid if C_USE_FSYNC = 1,2.</p>
4	FrameCntEn	0	R/W	<p>Configures the MM2S channel to allow only IRQFrameCount number of transfers to occur. After IRQFrameCount frames have been transferred, the MM2S channel halts, DMACR.RS bit is cleared to 0, and DMASR.Halted asserts to 1 when the channel has completely halted.</p>

Table 2-11: MM2S_DMACR Register Details (Cont'd)

Bits	Field Name	Default Value	Access Type	Description
3	GenlockEn	0	R/W	<p>Enables Genlock or Dynamic Genlock Synchronization.</p> <ul style="list-style-type: none"> 0 = Genlock or Dynamic Genlock Synchronization disabled. Genlock input is ignored by MM2S. 1 = Genlock or Dynamic Genlock Synchronization enabled. MM2S synchronized to Genlock frame input. <p>Note: This value is only valid when the channel is configured as Genlock Slave or Dynamic Genlock Master or Dynamic Genlock Slave (C_MM2S_GENLOCK_MODE = 1 or 2 or 3). If configured for Genlock Master mode (C_MM2S_GENLOCK_MODE = 0), this bit is reserved and always reads as zero.</p> <p>See Genlock Synchronization in Chapter 3 for more details on different Genlock modes.</p>
2	Reset	0	R/W	<p>Soft reset for resetting the AXI VDMA MM2S channel. Setting this bit to a 1 causes the AXI VDMA MM2S channel to be reset. Reset is accomplished gracefully. Pending commands/transfers are flushed or completed. AXI4-Stream reset output is asserted. Setting DMACR.Reset = 1 only resets the MM2S channel. After completion of a soft reset all MM2S registers and bits are in the Reset State.</p> <p>0 = Reset NOT in progress — Normal operation 1 = Reset in progress</p>

Table 2-11: MM2S_DMACR Register Details (Cont'd)

Bits	Field Name	Default Value	Access Type	Description
1	Circular_Park	1	R/W	Indicates frame buffer Circular mode or frame buffer Park mode. 0 = Park Mode— Engine will park on frame buffer referenced by PARK_PTR_REG.RdFrmPntrRef. 1 = Circular Mode — Engine continuously circles through MM2S_FRMSTORE frame buffers.
0	RS	0	R/W	Run / Stop controls running and stopping of the VDMA channel. For any DMA operations to commence, the AXI VDMA engine must be running (DMACR.RS=1). 0 = Stop — VDMA stops when current (if any) DMA operations are complete. Fetched descriptors are flushed inside VDMA. The halted bit in the DMA Status Register asserts to 1 when the DMA engine is halted. This bit gets cleared by AXI VDMA hardware when an error occurs or when the IRQFrameCount is reached when Frame Count Enable is asserted (DMACR.FrameCntEn = 1). The CPU can also choose to clear this bit to stop DMA operations. 1 = Run — Start DMA operations. The halted bit in the DMA Status Register deasserts to 0 when the DMA engine begins operations. Note: On Run/Stop clear, in-progress stream transfers might terminate early.

MM2S_DMASR (MM2S DMA Status Register – Offset 04h) (C_INCLUDE_SG = 1/0)

This register provides the status for the Memory Map to Stream DMA Channel for both Scatter Gather mode and Register Direct mode.

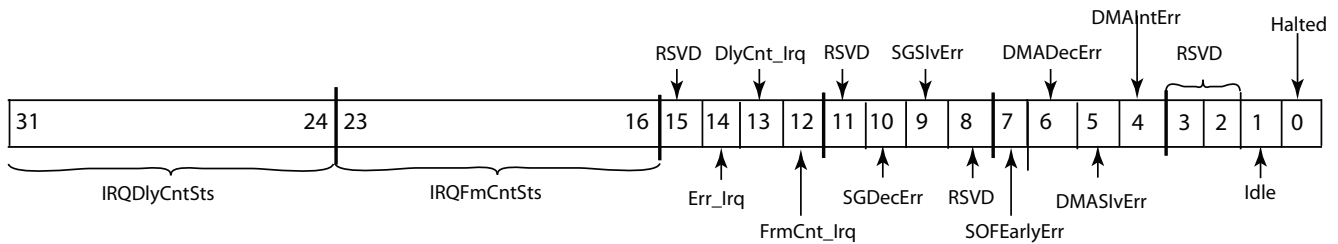

Figure 2-4: MM2S DMASR Register

Table 2-12: MM2S_DMASR Register Details

Bits	Field Name	Default Value	Access Type	Description
31 downto 24	IRQDelayCntSts	00h	RO	Interrupt Delay Count Status. Indicates current interrupt delay time value.
23 downto 16	IRQFrameCntSts	01h	RO	Interrupt Frame Count Status. Indicates current interrupt frame count value.
15	Reserved	0	RO	Always read as zero.
14	Err_Irq	0	R/WC	Interrupt on Error. <ul style="list-style-type: none"> • 0 = No error Interrupt. • 1 = Error interrupt detected. If enabled (DMACR.Err_IrqEn = 1), an interrupt out is generated when error is detected.
13	DlyCnt_Irq	0	R/WC	Interrupt on Delay. <ul style="list-style-type: none"> • 0 = No Delay Interrupt. • 1 = Delay Interrupt detected. If enabled (DMACR.DlyCnt_IrqEn = 1), an interrupt out is generated when delay count reaches its programmed value.
12	FrmCnt_Irq	0	R/WC	Frame Count Interrupt. <ul style="list-style-type: none"> • 0 = No Frame Count Interrupt. • 1 = Frame Count Interrupt detected. If enabled (DMACR.FrmCnt_IrqEn = 1) and if the interrupt threshold has been met, an interrupt out is generated from the AXI VDMA
11	Reserved	0	RO	Writing to this bit has no effect, and it is always read as zeros.
10	SGDecErr	0	RO	Scatter Gather Decode Error. <ul style="list-style-type: none"> • 0 = No SG Decode Errors. • 1 = SG Decode Error detected. DMA Engine halts. See Errors for more information.
9	SGSlvErr	0	RO	Scatter Gather Slave Error. <ul style="list-style-type: none"> • 0 = No SG Slave Errors. • 1 = SG Slave Error detected. DMA Engine halts. See Errors for more information.
8	Reserved	0	RO	Writing to this bit has no effect, and it is always read as zeros.

Table 2-12: MM2S_DMASR Register Details (Cont'd)

Bits	Field Name	Default Value	Access Type	Description
7	SOFEarlyErr	0	RO or R/WC	Start of Frame Early Error <ul style="list-style-type: none"> • 0 = No Start of Frame Error • 1 = Start of Frame Early Error detected This error occurs if mm2s_fsync is received before the completion of frame on streaming interface. Note: In Flush On Frame Sync mode, this bit is R/WC (Write 1 to Clear) bit. Otherwise it is a Read Only bit.
6	DMADecErr	0	RO	DMA Decode Error. This error occurs if the address request is to an invalid address. <ul style="list-style-type: none"> • 0 = No DMA Decode Errors. • 1 = DMA Decode Error detected. DMA channel halts.
5	DMASlvErr	0	RO	DMA Slave Error. <ul style="list-style-type: none"> • 0 = No DMA Slave Errors. • 1 = DMA Slave Error detected. DMA Engine halts. This error occurs if the slave read from the Memory Map interface issues a Slave Error.
4	DMAIntErr	0	RO or R/WC	DMA Internal Error. <ul style="list-style-type: none"> • 0 = No DMA Internal Errors. • 1 = DMA Internal Error detected. DMA channel halts. This error occurs during one of the following conditions: <ul style="list-style-type: none"> • Descriptor is fetched with hsize or vsize = 0 in Scatter Gather mode • HSIZE or VSIZE register were written zeros in Register Direct mode • Transferred frame size is greater than vsize values Note: In Flush On Frame Sync mode, this bit is R/WC (Write 1 to Clear) bit. Otherwise its a Read Only bit.
3 downto 2	Reserved	0	RO	Writing to these bits has no effect, and they are always read as zeros.

Table 2-12: MM2S_DMASR Register Details (Cont'd)

Bits	Field Name	Default Value	Access Type	Description
1	Idle	0	RO	<p>DMA Scatter Gather Engine Idle. In Scatter Gather Mode (C_INCLUDE_SG = 1) this bit indicates the state of AXI VDMA Scatter Gather Engine operations. The assertion of Idle indicates the SG Engine has reached the tail pointer for the associated channel and all queued descriptors have been processed. If in the Idle state (DMASR.Idle = 1), writing to the TailPointer register automatically restarts DMA operations.</p> <p>For Register Direct Mode (C_INCLUDE_SG = 0) this bit is reserved and always read as 0b.</p> <ul style="list-style-type: none"> • 0 = Not Idle — SG operations for MM2S channel in progress. • 1 = Idle — SG operation for MM2S channel paused. <p>Note: DMASR.Idle only asserts after the SG engine has passed through the descriptor chain at least once and has reached the TAILDESC.</p> <p>Note: Writing to the TAILDESC register when not Idle (DMASR.Idle = 0) produces undefined results.</p>
0	Halted	1	RO	<p>DMA Channel Halted. DMA Channel Halted. Indicates the run/stop state of the DMA channel.</p> <ul style="list-style-type: none"> • 0 = DMA channel running • 1 = DMA channel halted. This bit gets set when DMACR.RS = 0 and DMA and SG operations have halted. There can be a lag of time between when DMACR.RS = 0 and when DMASR.Halted = 1. <p>Note: When halted (RS= 0 and Halted = 1), writing to CURDESC or TAILDESC pointer registers in Scatter Gather mode (C_INCLUDE_SG = 1) or Register Direct Mode (C_INCLUDE_SG = 0) has no effect on DMA operations.</p>

MM2S_CURDESC (MM2S DMA Current Descriptor Pointer Register– Offset 08h) (C_INCLUDE_SG = 1)

This register provides a Current Descriptor Pointer for the Memory Map to Stream DMA Scatter Gather Descriptor Management.

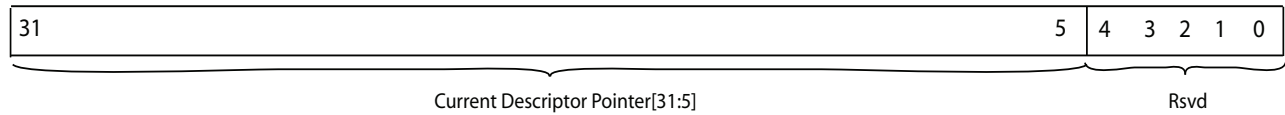

Figure 2-5: MM2S CURDESC Register

Table 2-13: MM2S_CURDESC Register Details

Bits	Field Name	Default Value	Access Type	Description
31 downto 5	Current Descriptor Pointer	zeros	R/W (RO)	<p>In Scatter Gather Mode (C_INCLUDE_SG = 1) indicates the pointer of the current descriptor being worked on. This register must contain a pointer to a valid descriptor prior to writing the TAILDESC register. Otherwise, undefined results occur. When DMACR.RS is 1, CURDESC becomes Read Only (RO) and is used to fetch the first descriptor.</p> <p>When the DMA Engine is running (DMACR.RS=1), CURDESC registers are updated by AXI VDMA to indicate the current descriptor being worked on.</p> <p>On Scatter Gather error detection, CURDESC is updated to reflect the descriptor associated with the detected error.</p> <p>The register can only be written to by the CPU when the DMA Engine is Halted (DMACR.RS=0 and DMASR.Halted =1). At all other times, this register is Read Only (RO). Descriptors must be 8-word aligned, that is, 0x00, 0x20, 0x40, and so on. Any other alignment has undefined results.</p> <p>In Register Direct Mode (C_INCLUDE_SG = 0) this field is reserved and always read as zeros.</p>
4 downto 0	Reserved	0	RO	Writing to these bits has no effect, and they are always read as zeros.

MM2S_TAILDESC (MM2S DMA Tail Descriptor Pointer Register– Offset 10h) (C_INCLUDE_SG = 1)

This register provides the Tail Descriptor Pointer for the Memory Map to Stream DMA Scatter Gather Descriptor Management.

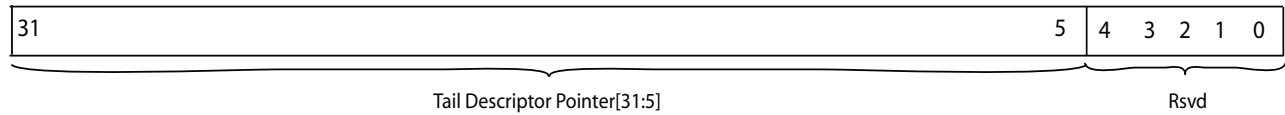

Figure 2-6: MM2S_TAILDESC Register

Table 2-14: MM2S_TAILDESC Register Details

Bits	Field Name	Default Value	Access Type	Description
31 downto 5	Tail Descriptor Pointer	zeros	R/W (RO)	<p>In Scatter Gather Mode (C_INCLUDE_SG = 1), indicates the pause pointer in a descriptor chain. The AXI VDMA SG Engine pauses descriptor fetching after completing operations on the descriptor whose current descriptor pointer matches the tail descriptor pointer. When AXI VDMA Channel is not Halted (DMASR.Halted = 0), a write by the CPU to the TAILDESC register causes the AXI VDMA SG Engine to start fetching descriptors or restart if it was idle (DMASR.Idle = 1). Writing to the TAILDESC when not idle (DMASR.Idle = 0) has undefined results.</p> <p>If the AXI DMA Channel is Halted (DMASR.Halted = 1 and DMACR.RS = 0), a write by the CPU to the TAILDESC register has no effect except to reposition the pause point.</p> <p>Note: Descriptors must be 8-word aligned, that is, 0x00, 0x20, 0x40, and so on. Any other alignment has undefined results.</p> <p>Note: In Register Direct Mode (C_INCLUDE_SG = 0) this field is reserved and always read as zeros.</p>
4 downto 0	Reserved	0	RO	Writing to these bits has no effect, and they are always read as zeros.

MM2S_REG_INDEX (MM2S Register Index - Offset 14h) (C_INCLUDE_SG = 0)

This register provides access to upper bank of 16 (that is, 17 through 32) start addresses. This register is reserved if C_NUM_FSTORE < 17 (writing has no effect, read returns 0).

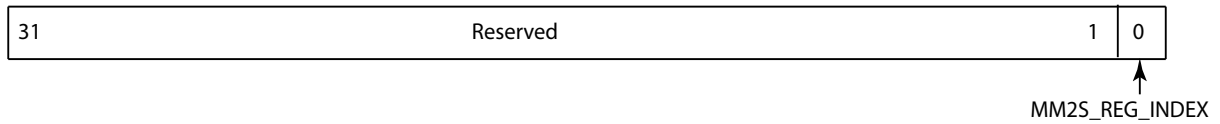

Figure 2-7: MM2S Register Index

Table 2-15: MM2S Register Index (MM2S_REG_INDEX – Offset 0x14)

Bits	Field Name	Default/Reset State	Access	
31 downto 1		Reserved	RO	Always read as zero
0	MM2S Reg Index	zeroes	R/W	<p>When set, enables access to the next set of 16 Frame Store Start Addresses (Bank1- 17 through 32) depending upon the following cases:</p> <p>Case 1: When C_NUM_FSTORES is less than or equal to 16, Bank1 (17 thru 32) registers are not available. Any writes to this bit do not change the behavior of VDMA.</p> <p>Case 2: When C_NUM_FSTORES is greater than 16 but less than 32</p> <ul style="list-style-type: none"> • 0 = Any write or read access between 0x5C to 0x98 accesses the Bank0 (1 thru 16) Frame StoreStart Address registers. • 1 = Accesses Bank1 registers. Example: If C_NUM_FSTORES = 20, Bank0 has 1-16 Frame Store Start Addresses and Bank1 has 17-20 Frame Store Start Addresses. Any access to Frame Store Start Addresses above 20 has no effect on writes and returns zero on reads. <p>Case 3.: When C_NUM_FSTORES is equal to 32</p> <ul style="list-style-type: none"> • 0 = Any write or read access between 0x5C to 0x98 accesses the Bank0 registers. • 1 = Any write or read access between 0x5C to 0x98 accesses the Bank1 registers.

Note: MM2S_REG_INDEX register is not present in case of SG=1 mode.

Note: The existing VDMA behavior of Dynamic MM2S Frame Store selection (MM2S) remains unchanged with the addition of the MM2S_REG_INDEX register.

MM2S_FRMSTORE (MM2S Frame Store Register– Offset 18h) (C_INCLUDE_SG = 1/0)

This register provides the number of Frame Stores to use for the Memory Map to Stream channel.

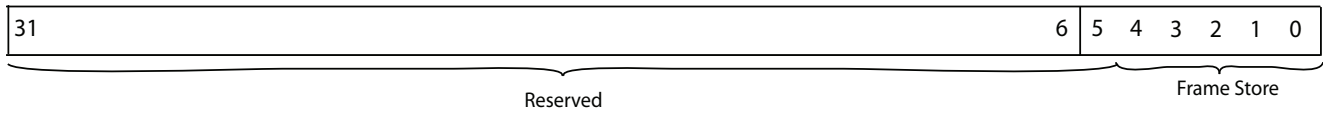

Figure 2-8: MM2S_FRMSTORE Register

Table 2-16: MM2S_FRMSTORE Register Details

Bits	Field Name	Default Value	Access Type	Description
31 downto 6	Reserved	zeroes	RO	Writing to these bits has no effect, and they are always read as zeros.
5 downto 0	Frame Store	C_NUM_FSTORES	R/W	<p>Indicates the number of frame stores to use for video data transfers. This value defaults to C_NUM_FSTORES. For Scatter Gather mode (C_INCLUDE_SG = 1), this value specifies the number of Scatter Gather Descriptors required. For Register Direct mode (C_INCLUDE_SG = 0) this value specifies the number of Start Address registers used for transfers. On reset and start-up this register is set to C_NUM_FSTORES.</p> <p>Note: Genlock Masters and their attached Genlock Slaves must have identical Frame Store settings. Any mismatch in values has undefined results.</p> <p>Note: Dynamic Genlock Masters and their attached Dynamic Genlock Slaves must have identical Frame Store settings. Any mismatch in values has undefined results.</p> <p>Note: Values written must be greater than 0 and less than or equal to C_NUM_FSTORES. Any other value has undefined results.</p>

MM2S_THRESHOLD (MM2S Line Buffer Threshold Register– Offset 1Ch) (C_INCLUDE_SG = 1/0)

This register provides the Line Buffer Threshold for the Memory Map to Stream channel.

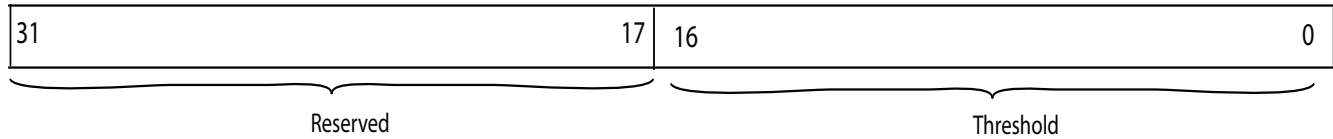

Figure 2-9: MM2S_THRESHOLD Register

Table 2-17: MM2S_THRESHOLD Register Details

Bits	Field Name	Default Value	Access Type	Description																		
31 downto 17	Reserved	zeroes	RO	Reserved. Always read as zero																		
16 downto 0	Line Buffer Threshold	C_MM2S_LINEBUFFER_THRESH	R/W	<p>Threshold point at which MM2S line buffer almost empty flag asserts high. Threshold specified in bytes and must be a multiple of C_M_AXIS_MM2S_TDATA_WIDTH/8, subject to the following condition. When Stream Data Width value is equal to a non-power of 2 value (that is, 24, 40, 72, 136, 264, 520), Threshold follows the restriction imposed by the next nearest upper power of 2 value (that is, 32, 64, 128, 256, 512, 1024 respectively).</p> <table border="0"> <tr> <td>Stream Data Width</td> <td>Allowed Values</td> </tr> <tr> <td>8</td> <td>1, 2, 3,.....</td> </tr> <tr> <td>16</td> <td>2, 4, 6,.....</td> </tr> <tr> <td>24, 32</td> <td>4, 8, 12,.....</td> </tr> <tr> <td>40 to 64</td> <td>8, 16, 24,.....</td> </tr> <tr> <td>72 to 128</td> <td>16, 32, 48,.....</td> </tr> <tr> <td>136 to 256</td> <td>32, 64, 96,.....</td> </tr> <tr> <td>264 to 512</td> <td>64, 128, 192,.....</td> </tr> <tr> <td>520 to 1024</td> <td>128, 256, 384,.....</td> </tr> </table> <p>Note: Maximum threshold value is limited by C_MM2S_LINEBUFFER_DEPTH.</p> <p>Note: Value valid when MM2S line buffer is included (C_MM2S_LINEBUFFER_DEPTH > 0).</p>	Stream Data Width	Allowed Values	8	1, 2, 3,.....	16	2, 4, 6,.....	24, 32	4, 8, 12,.....	40 to 64	8, 16, 24,.....	72 to 128	16, 32, 48,.....	136 to 256	32, 64, 96,.....	264 to 512	64, 128, 192,.....	520 to 1024	128, 256, 384,.....
Stream Data Width	Allowed Values																					
8	1, 2, 3,.....																					
16	2, 4, 6,.....																					
24, 32	4, 8, 12,.....																					
40 to 64	8, 16, 24,.....																					
72 to 128	16, 32, 48,.....																					
136 to 256	32, 64, 96,.....																					
264 to 512	64, 128, 192,.....																					
520 to 1024	128, 256, 384,.....																					

FRMPTR_STS (MM2S and S2MM Current Frame Pointer Status -- Offset 24h) (C_INCLUDE_SG = 1/0)

This register provides current operating frame pointer status of both MM2S and S2MM channels. This helps in tracking frame pointers when they are operating in different Genlock modes.

Table 2-18: FRMPTR_STS Register Details

Bits	Field Name	Default Value	Access Type	Description
31 downto 29	Reserved	0	RO	Writing to these bits has no effect, and they are always read as zeros.
28 downto 24	S2MMFrmPtrIn	0	RO	S2MM Frame Pointer Input <ul style="list-style-type: none"> • Reserved if S2MM channel is Genlock Master • Indicates Genlock Master frame pointer value if S2MM channel is Genlock Slave • Indicates Dynamic Genlock Slave frame pointer value if S2MM channel is Dynamic Genlock Master • Indicates Dynamic Genlock Master frame pointer value if S2MM channel is Dynamic Genlock Slave
23 downto 21	Reserved	0	RO	Writing to these bits has no effect, and they are always read as zeros.
20 downto 16	S2MMFrmPtrOut	0	RO	Indicates current working frame of S2MM channel.
15 downto 13	Reserved	0	RO	Writing to these bits has no effect, and they are always read as zeros.
12 downto 8	MM2SFrmPtrIn	0	RO	MM2S Frame Pointer Input <ul style="list-style-type: none"> • Reserved if MM2S channel is Genlock Master • Indicates Genlock Master frame pointer value if MM2S channel is Genlock Slave • Indicates Dynamic Genlock Slave frame pointer value if MM2S channel is Dynamic Genlock Master • Indicates Dynamic Genlock Master frame pointer value if MM2S channel is Dynamic Genlock Slave
7 downto 5	Reserved	0	RO	Writing to these bits has no effect, and they are always read as zeros.
4 downto 0	MM2SFrmPtrOut	0	RO	Indicates current working frame of MM2S channel.

PARK_PTR_REG (Park Pointer Register – Offset 28h) (C_INCLUDE_SG = 1/0)

This register provides Park Pointer Registers for the Memory Map to Stream and Stream to Memory Map DMA transfer Management.

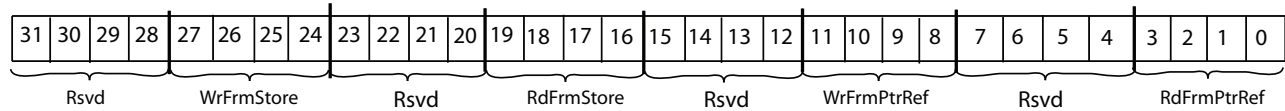

Figure 2-10: PARK_PTR_REG Register

Table 2-19: PARK_PTR_REG Register Details

Bits	Field Name	Default Value	Access Type	Description
31 downto 29	Reserved	0	RO	Writing to these bits has no effect, and they are always read as zeros.
28 downto 24	WrFrmStore		RO	Write Frame Store. Indicates current frame being operated on by S2MM channel. During DMA operations this value continually updates as each frame is processed. During error conditions, the value is updated with the current frame being operated on when the error occurred. It will again start tracking frames when all errors are cleared.
23 downto 21	Reserved	0	RO	Writing to these bits has no effect, and they are always read as zeros.
20 downto 16	RdFrmStore		RO	Read Frame Store. Indicates current frame being operated on by MM2S channel. During DMA operations this value continually updates as each frame is processed. During error conditions, the value is updated with the current frame being operated on when the error occurred. It will again start tracking frames when all errors are cleared.
15 downto 13	Reserved	0	RO	Writing to these bits has no effect, and they are always read as zeros.
12 downto 8	WrFrmPtrRef		R/W	Write Frame Pointer Reference. When Parked (DMACR.Circular_Park = 0), references the S2MM Frame to park on.
7 downto 5	Reserved	0	RO	Writing to these bits has no effect, and they are always read as zeros.
4 downto 0	RdFrmPtrRef		R/W	Read Frame Pointer Reference. When Parked (DMACR.Circular_Park = 0) references the MM2S Frame to park on.

VDMA_VERSION (AXI VDMA Version Register – Offset 2Ch) (C_INCLUDE_SG = 1/0)

This register provides the AXI VDMA Version.

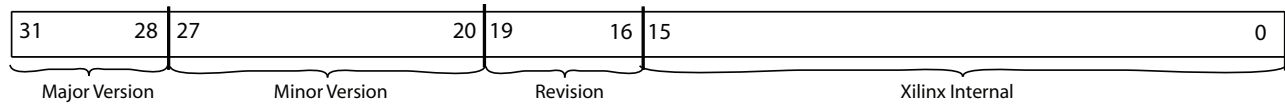

Figure 2-11: VDMA_VERSION Register

Table 2-20: VDMA_VERSION Register Details

Bits	Field Name	Default Value	Access Type	Description
31 downto 28	Major Version	5h	RO	Single 4-bit hexadecimal value. v1 = 1h, v2=2h, v3=3h, and so on.
27 downto 20	Minor Version	04h	RO	Two separate 4-bit hexadecimal values. 00 = 00h, 01 = 01h, and so on.
19 downto 16	Revision	Ah	RO	Revision letter as a hexadecimal character from 'a' to 'f'. Mapping is as follows: Ah-> 'a', Bh -> 'b', Ch-> 'c', and so on.
15 downto 0	Xilinx Internal	various	RO	Reserved for Internal Use Only. Integer value from 0 to 9999.

Stream to Memory Map Register Detail

S2MM_DMCCR (S2MM DMA Control Register – Offset 30h) (C_INCLUDE_SG = 1/0)

This register provides control for the Stream to Memory Map DMA Channel.

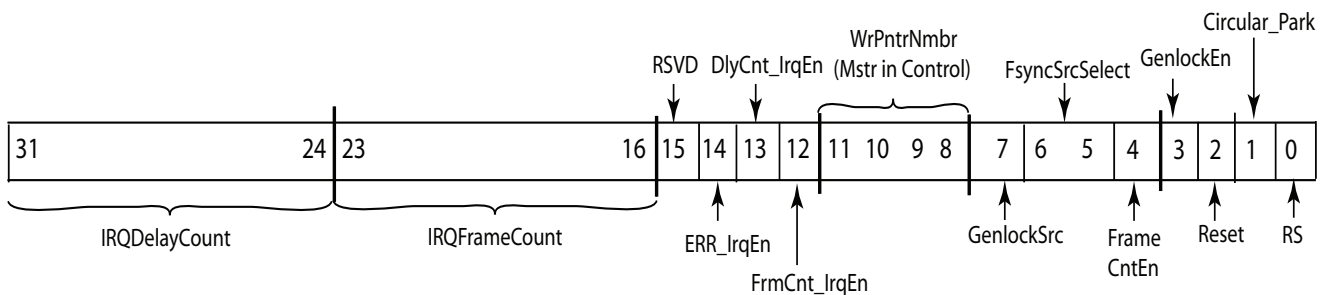

Figure 2-12: S2MM DMCCR Register

Table 2-21: S2MM_DMCCR Register Details

Bits	Field Name	Default Value	Access Type	Description
31 downto 24	IRQDelayCount	0x00	R/W	<p>This value is used for setting the interrupt delay count value. The delay count interrupt is a mechanism for causing the DMA engine to generate an interrupt after the delay period has expired. Timer begins counting either upon receipt of frame sync (if C_USE_FSYNC=1,2,3) or completion of vsize lines (if C_USE_FSYNC=0). It resets with subsequent start of packet (s_axis_s2mm_tvalid) assertion. When a value different than the current IRQDelayCount is written to this field, the internal delay counter is reset to the new value.</p> <p>Note: Setting this value to zero disables the delay counter interrupt.</p>
23 downto 16	IRQFrameCount	01h	R/W	<p>Interrupt Frame Count. This value is used for setting the interrupt threshold. When a frame transfer interrupt events occur, an internal counter counts down from the Interrupt Frame Count setting. On the frame boundary after count reaches 1, an interrupt out is generated by the VDMA engine. When an IRQFrameCount value, different than what is currently set, is written to the IRQFrameCount field, the internal frame counter is reset to the new IRQFrameCount value.</p> <p>Note: The minimum setting for the threshold is 0x01. A write of 0x00 to this register sets the threshold to 0x01.</p> <p>Note: When DMCCR.FrameCntEn = 1, this value determines the number of frame buffers to process.</p>
15	Reserved	0	RO	Writing to this bit has no effect and it is always read as zeros.
14	Err_IrqEn	0	R/W	<p>Interrupt on Error Interrupt Enable. When set to 1, allows DMASR.Err_Irq to generate an interrupt out.</p> <ul style="list-style-type: none"> 0 = Error Interrupt disabled 1 = Error Interrupt enabled
13	DlyCnt_IrqEn	0	R/W	<p>Delay Count Interrupt Enable. When set to 1, allows DMASR.DlyCnt_Irq to generate an interrupt out.</p> <ul style="list-style-type: none"> 0 = Delay Count Interrupt disabled 1 = Delay Count Interrupt enabled
12	FrmCnt_IrqEn	0	R/W	<p>Frame Count Complete Interrupt Enable. When set to 1, allows DMASR.FrmCnt_Irq to generate an interrupt out when IRQFrameCount value reaches zero.</p> <ul style="list-style-type: none"> 0 = Frame Count Interrupt disabled 1 = Frame Count Interrupt enabled

Table 2-21: S2MM_DMACR Register Details (Cont'd)

Bits	Field Name	Default Value	Access Type	Description
11 downto 8	WrPntrNum	zeroes	R/W	<p>Indicates the master in control when S2MM channel is configured for Genlock slave/Dynamic Genlock Master/Dynamic Genlock Slave (C_S2MM_GENLOCK_MODE = 1,2,3).</p> <ul style="list-style-type: none"> • 0000b = Controlling entity is Entity 1 • 0001b = Controller entity is Entity 2 • 0010b = Controller entity is Entity 3 and so on <p>Note: Maximum valid WrPntrNum is C_S2MM_GENLOCK_NUM_MASTER - 1. Setting to a value greater than C_S2MM_GENLOCK_NUM_MASTER - 1 has undefined results. See Genlock Synchronization in Chapter 3 for more details on different Genlock modes.</p>
7	GenlockSrc	0	R/W	<p>Sets the Genlock source for Genlock slaves</p> <ul style="list-style-type: none"> • 0 = External Genlock • 1 = Internal Genlock <p>This bit has meaning only:</p> <ul style="list-style-type: none"> • if both VDMA channels are enabled AND • if one VDMA channel is configured as Genlock Master then the other VDMA channel <i>must</i> be configured as Genlock Slave OR if one VDMA channel is configured as Dynamic Genlock Master then other VDMA channel <i>must</i> be configured as Dynamic Genlock Slave AND • if C_INCLUDE_INTERNAL_GENLOCK = 1 <p>See Genlock Synchronization in Chapter 3 for more details on different Genlock modes.</p>
6 downto 5	FsyncSrcSelect	00	R/W	<p>Selects the frame sync source for the S2MM channel. The frame sync source is selected as follows:</p> <ul style="list-style-type: none"> • 00 = s2mm_fsync • 01 = mm2s_fsync • 10 = s_axis_s2mm_tuser(0) --] When C_S2MM_ENABLE_SOF = 1 else reserved • 11 = Reserved <p>Note: Frame Sync Source select is valid only if (C_USE_FSYNC=1,3).</p>
4	FrameCntEn	0	R/W	<p>Configures VDMA to allow only IRQFrameCount number of transfers to occur. After the IRQFrameCount frames are completely transferred, the axi_vdma channel halts, DMACR.RS bit is deasserted and the DMASR.Halted asserts when the channel has completely halted.</p>

Table 2-21: S2MM_DMACR Register Details (Cont'd)

Bits	Field Name	Default Value	Access Type	Description
3	GenlockEn	0	R/W RO	<p>Enables Genlock or Dynamic Genlock Synchronization.</p> <ul style="list-style-type: none"> 0 = Genlock or Dynamic Genlock Synchronization disabled. Genlock input is ignored by S2MM. 1 = Genlock or Dynamic Genlock Synchronization enabled. S2MM synchronized to Genlock frame input. <p>Note: This value is only valid when the channel is configured as Genlock Slave or Dynamic Genlock Master or Dynamic Genlock Slave(C_S2MM_GENLOCK_MODE = 1 or 2 or 3). If configured for Genlock Master mode (C_S2MM_GENLOCK_MODE = 0), this bit is reserved and always reads as zero.</p> <p>See Genlock Synchronization in Chapter 3 for more details on different Genlock modes.</p> <p>Note: R/W when C_S2MM_GENLOCK_MODE = 1, Reserved and RO when C_S2MM_GENLOCK_MODE = 0.</p>
2	Reset	0	R/W	<p>Soft reset for resetting the AXI VDMA S2MM channel. Setting this bit to a 1 causes the AXI VDMA S2MM channel to be reset. Reset is accomplished gracefully. Pending commands/transfers are flushed or completed. AXI4-Stream reset output is asserted. Setting DMACR.Reset = 1 only resets the S2MM channel. After completion of a soft reset, all S2MM registers and bits are in the Reset State.</p> <ul style="list-style-type: none"> 0 = Reset NOT in progress - Normal operation 1 = Reset in progress

Table 2-21: S2MM_DMACR Register Details (Cont'd)

Bits	Field Name	Default Value	Access Type	Description
1	Circular_Park	1	R/W	<p>When set to 1, indicates Circular Buffer Mode and frame buffers are processed in a circular manner. When set to 0, indicates Park Mode and channel will park on the frame buffer referenced by PARK_PTR_REG.WrFrmPntrRef.</p> <ul style="list-style-type: none"> • 0 = Park – Engine will park on the frame buffer referenced by PARK_PTR_REG.WrFrmPntrRef. • 1 = Tail Pointer Mode/Circular Buffer Mode. SG Descriptor is processed until the TAILDESC pointer is reached if SG engine is included and start address is cycled through in a circular manner. <p>Note: Transitions to/from Park and Circular Buffer modes occur on frame sync boundaries.</p> <p>Note: For Scatter Gather Mode (C_INCLUDE_SG = 1), Park Mode must only be enabled when AXI VDMA is Idle (DMASR.Idle = 1) and NOT halted (DMASR.Halted = 0). Undefined results occur if enabled at any other time.</p> <p>Note: For non-Scatter Gather Mode (C_INCLUDE_SG = 0), Park Mode can be specified at any time.</p>
0	RS	0	R/W	<p>Run / Stop. Controls running and stopping of the VDMA channel. For any DMA operations to commence the AXI VDMA engine must be running (DMACR.RS=1).</p> <ul style="list-style-type: none"> • 0 = Stop – VDMA stops when current (if any) DMA operations are complete. The halted bit in the DMA Status Register asserts to 1 when the DMA engine is halted. This bit gets cleared by the AXI VDMA hardware when an error occurs. The CPU can also choose to clear this bit to stop DMA operations. • 1 = Run – Start DMA operations. The halted bit in the DMA Status Register deasserts to 0 when the DMA engine begins operations. <p>Note: If Run/Stop is cleared, in-progress stream transfers might terminate early.</p>

S2MM_DMASR (S2MM DMA Status Register – Offset 34h) (C_INCLUDE_SG = 1/0)

This register provides the status for the Stream to Memory Map DMA Channel.

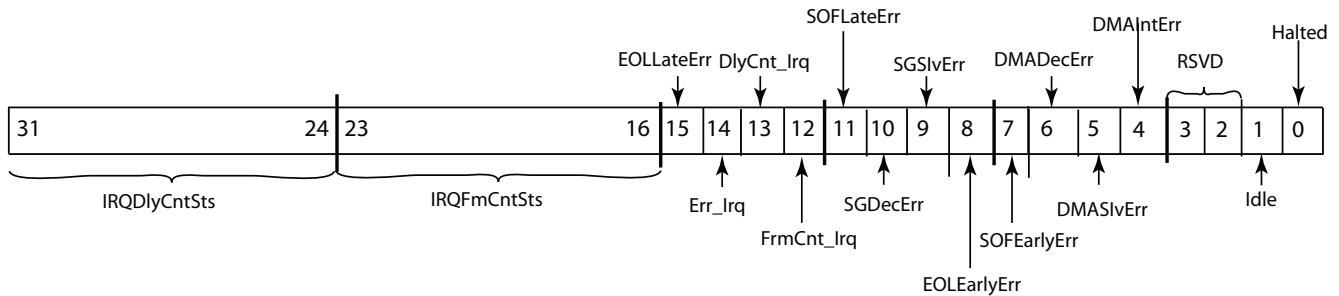

Figure 2-13: S2MM DMASR Register

Table 2-22: S2MM_DMASR Register Details

Bits	Field Name	Default Value	Access Type	Description
31 downto 24	IRQDelayCntSts	00h	RO	Interrupt Delay Count Status. Indicates current interrupt delay time value.
23 downto 16	IRQFrameCntSts	01h	RO	Interrupt Frame Count Status. Indicates current interrupt frame count value.
15	EOLLateErr	0	R/WC	End of Line Late Error. <ul style="list-style-type: none"> 0 = No End of Line Late Error 1 = End of Line Late Error detected. VDMA does not halt This error occurs if incoming line size is greater than programmed hsize value. Write 1 to clear.
14	Err_Irq	0	R/WC	Interrupt on Error. When set to 1, indicates an interrupt event was generated on error. If enabled (DMACR.Err_IrqEn = 1), an interrupt out is generated from the AXI VDMA. 0 = No error Interrupt. 1 = Error interrupt detected.
13	DlyCnt_Irq	0	R/WC	Interrupt on Delay. Delay counter begins counting at the beginning of each frame and resets at delay count or transfer of video line. If delay count reached, the bit sets to 1, indicating an interrupt event was generated due to delay counter. If enabled (DMACR.DlyCnt_IrqEn = 1), an interrupt out is generated from the AXI VDMA. <ul style="list-style-type: none"> 0 = No Delay Interrupt. 1 = Delay Interrupt detected.

Table 2-22: S2MM_DMASR Register Details (Cont'd)

Bits	Field Name	Default Value	Access Type	Description
12	FrmCnt_Irq	0	R/WC	Frame Count Interrupt. When set to 1, indicates a Frame Count interrupt event was generated. This occurs when DMACR.FrameCount frames have been transferred. If enabled (DMACR.FrmCnt_IrqEn = 1) and if the interrupt threshold has been met, an interrupt out is generated from the AXI VDMA. <ul style="list-style-type: none"> • 0 = No Frame Count Interrupt. • 1 = Frame Count Interrupt detected.
11	SOFLateErr	0	R/WC	Start of Frame Late Error. <ul style="list-style-type: none"> • 0 = No Start of Frame Late Error • 1 = Start of Frame Late Error detected. VDMA does not halt This error occurs if incoming frame size is greater than programmed vsize value. Write 1 to Clear in flush on fsync mode.
10	SGDecErr	0	RO	Scatter Gather Decode Error. <ul style="list-style-type: none"> • 0 = No SG Decode Errors. • 1 = SG Decode Error detected. DMA Engine halts. See the Errors for more information.
9	SGSlvErr	0	RO	Scatter Gather Slave Error. <ul style="list-style-type: none"> • 0 = No SG Slave Errors. • 1 = SG Slave Error detected. DMA Engine halts. See the Errors for more information.
8	EOLEarlyErr	0	R/WC	End of Line Early Error. <ul style="list-style-type: none"> • 0 = No End of Line Early Error • 1 = End of Line Early Error detected. VDMA does not halt This error occurs if incoming line size is lesser than programmed hsize value. Write 1 to clear.
7	SOFEarlyErr	0	RO or R/WC	Start of Frame Early Error. <ul style="list-style-type: none"> • 0 = No Start of Frame Early Error • 1 = Start of Frame Early Error detected. VDMA does not halt This error occurs if incoming frame size is lesser than programmed vsize value. Write 1 to Clear in flush on fsync mode and Read Only otherwise.
6	DMADecErr	0	RO	DMA Decode Error. <ul style="list-style-type: none"> • 0 = No DMA Decode Errors. • 1 = DMA Decode Error detected. DMA channel halts. This error occurs if the address request is to an invalid address.

Table 2-22: S2MM_DMASR Register Details (Cont'd)

Bits	Field Name	Default Value	Access Type	Description
5	DMASlvErr	0	RO	DMA Slave Error. <ul style="list-style-type: none"> • 0 = No DMA Slave Errors. • 1 = DMA Slave Error detected. DMA Engine halts. This error occurs if the slave read from the Memory Map interface issues a Slave Error.
4	DMAIntErr	0	RO or R/WC	DMA Internal Error. <ul style="list-style-type: none"> • 0 = No DMA Internal Errors. • 1 = DMA Internal Error detected. DMA channel halts. This error occurs during one of the following conditions: <ul style="list-style-type: none"> • Descriptor fetched with hsize or vsize = 0 in Scatter Gather mode • HSIZE or VSIZE register were written zeros in Register Direct mode • Received frame size is greater than vsize lines Note: In Flush On Frame Sync mode, this bit is R/WC (Write 1 to Clear) bit. Otherwise its a Read Only bit.
3 downto 2	Reserved	0	RO	Writing to these bits has no effect and they are always read as zeros.

Table 2-22: S2MM_DMASR Register Details (Cont'd)

Bits	Field Name	Default Value	Access Type	Description
1	Idle	0	RO	<p>DMA Scatter Gather Engine Idle. In Scatter Gather Mode (C_INCLUDE_SG = 1) this bit indicates the state of AXI VDMA Scatter Gather Engine operations. The assertion of Idle indicates the SG Engine has reached the tail pointer for the associated channel and all queued descriptors have been processed. If in the Idle state (DMASR.Idle = 1), writing to the TailPointer register automatically restarts DMA operations.</p> <p>For Register Direct Mode (C_INCLUDE_SG = 0) this bit is reserved and always read as 0b.</p> <ul style="list-style-type: none"> • 0 = Not Idle — SG operations for S2MM channel in progress. • 1 = Idle — SG operation for S2MM channel paused. <p>Note: DMASR.Idle only asserts after the SG engine has passed through the descriptor chain at least once and has reached the TAILDESC.</p> <p>Note: Writing to the TAILDESC register when not Idle (DMASR.Idle = 0) produces undefined results.</p>
0	Halted	1	RO	<p>DMA Channel Halted.</p> <p>Indicates the run/stop state of the DMA channel.</p> <ul style="list-style-type: none"> • 0 = DMA channel running • 1 = DMA channel halted. This bit gets set when DMACR.RS = 0 and DMA and SG operations have halted. There can be a lag of time between when DMACR.RS = 0 and when DMASR.Halted = 1. <p>Note: When halted (RS= 0 and Halted = 1), writing to CURDESC or TAILDESC pointer registers has no effect on DMA operations.</p>

S2MM_CURDESC (S2MM DMA Current Descriptor Pointer Register– Offset 38h) (C_INCLUDE_SG = 1)

This register provides the Current Descriptor Pointer for the Stream to Memory Map DMA Scatter Gather Descriptor Management.

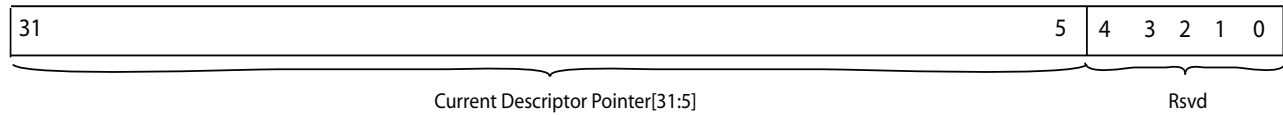

Figure 2-14: S2MM CURDESC Register

Table 2-23: S2MM_CURDESC Register Details

Bits	Field Name	Default Value	Access Type	Description
31 downto 5	Current Descriptor Pointer	zeros	R/W (RO)	In Scatter Gather Mode (C_INCLUDE_SG = 1) indicates the pointer of the current descriptor being worked on. This register must contain a pointer to a valid descriptor prior to writing to the TAILDESC register; otherwise, undefined results occur. When DMACR.RS is 1, CURDESC becomes Read Only (RO) and is used to fetch the first descriptor. When the DMA Engine is running (DMACR.RS=1), CURDESC registers are updated by AXI VDMA to indicate the current descriptor being worked on. On Scatter Gather error detection, CURDESC is updated to reflect the descriptor associated with the detected error. The register can only be written to by the CPU when the DMA Engine is Halted (DMACR.RS=0 and DMASR.Halted =1). At all other times, this register is Read Only (RO). Descriptors must be 8 word aligned, that is, 0x00, 0x20, 0x40, and so on. Any other alignment has undefined results. Note: In Register Direct Mode (C_INCLUDE_SG = 0) this field is reserved and always read as zeros.
4 downto 0	Reserved	0	RO	Writing to these bits has no effect, and they are always read as zeros.

S2MM_TAILDESC (S2MM DMA Tail Descriptor Pointer Register– Offset 40h) (C_INCLUDE_SG = 1)

This register provides the Tail Descriptor Pointer for the Stream to Memory Map DMA Scatter Gather Descriptor Management.

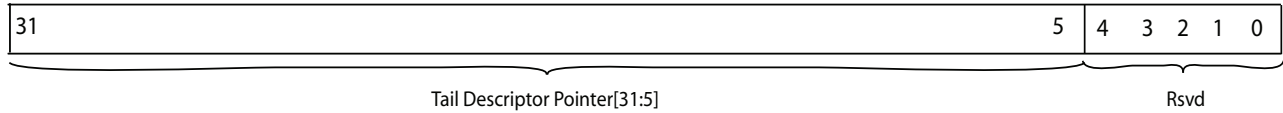

Figure 2-15: S2MM TAILDESC Register

Table 2-24: S2MM_TAILDESC Register Details

Bits	Field Name	Default Value	Access Type	Description
31 downto 5	Tail Descriptor Pointer	zeros	R/W (RO)	<p>In Scatter Gather Mode (C_INCLUDE_SG = 1) indicates the pause pointer in a descriptor chain. The AXI VDMA SG Engine pauses descriptor fetching after completing operations on the descriptor whose current descriptor pointer matches the tail descriptor pointer. When AXI VDMA Channel is not Halted (DMASR.Halted = 0), a write by the CPU to the TAILDESC register causes the AXI VDMA SG Engine to start fetching descriptors or restart if it was idle (DMASR.Idle = 1). Writing to the TAILDESC when not idle (DMASR.Idle = 0) has undefined results.</p> <p>If the AXI DMA channel is halted (DMASR.Halted = 1 and DMACR.RS = 0), a write by the CPU to the TAILDESC register has no effect except to reposition the pause point.</p> <p>Note: Descriptors must be 8-word aligned, that is, 0x00, 0x20, 0x40, and so on. Any other alignment has undefined results.</p> <p>Note: In Register Direct Mode (C_INCLUDE_SG = 0) this field is reserved and always read as zeros.</p>
4 downto 0	Reserved	0	RO	Writing to these bits has no effect, and they are always read as zeros.

S2MM_REG_INDEX (S2MM Register Index - Offset 44h) (C_INCLUDE_SG = 0)

This register provides access to upper bank of 16 (that is, 17 to 32) start addresses. This register is reserved if C_NUM_FSTORE < 17 (writing has no effect, read returns 0).

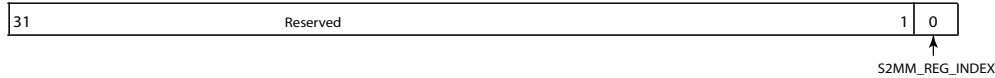

Figure 2-16: S2MM Register Index

Table 2-25: S2MM Register Index (S2MM_REG_INDEX - Offset 0x44)

Bits	Name	Default/Reset State	Access	Description
31 downto 1	Reserved		RO	Always read as zero
0	S2MM Reg Index	zeroes	RO	<p>When set, enables access to the next set of 16 Frame Store Start Addresses (Bank1- 17 through 32) depending upon the following cases:</p> <p>Case 1: When C_NUM_FSTORES is less than or equal to 16, Bank1 (17 thru 32) registers are not available. Any writes to this bit do not change the behavior of VDMA.</p> <p>Case 2: When C_NUM_FSTORES is greater than 16 but less than 32</p> <ul style="list-style-type: none"> • 0 = Any write or read access between 0xAC to 0xE8 accesses the Bank0 (1 through 16) Frame StoreStart Address registers. • 1 = Accesses Bank1 registers. Example: If C_NUM_FSTORES = 20, Bank0 will have 1-16 Frame Store Start Addresses and Bank1 will have 17-20 Frame Store Start Addresses. Any access to Frame Store Start Addresses above 20 has no effect on writes and returns zero on reads. <p>Case 3: When C_NUM_FSTORES is equal to 32</p> <ul style="list-style-type: none"> • 0 = Any write or read access between 0xAC to 0xE8 accesses the Bank0 registers. • 1 = Any write or read access between 0xAC to 0xE8 accesses the Bank1 registers.

Note: S2MM_REG_INDEX register is not present in case of SG =1 mode.

Note: The existing VDMA behavior of Dynamic S2MM Frame store selection (S2MM_FRMSTORE) remains unchanged with the addition of S2MM_REG_INDEX register.

S2MM_FRMSTORE (S2MM Frame Store Register – Offset 48h) (C_INCLUDE_SG = 1/0)

This register provides the number of Frame Stores to use for the Stream to Memory Map.

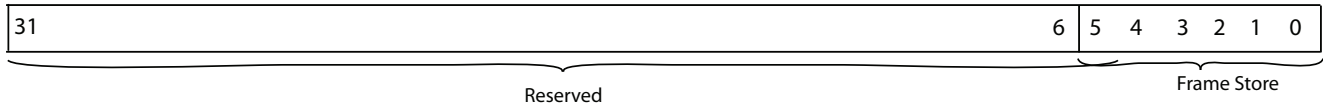

Figure 2-17: S2MM_FRMSTORE Register

Table 2-26: S2MM_FRMSTORE Register Details

Bits	Field Name	Default Value	Access Type	Description
31 downto 6	Reserved	0	RO	Writing to these bits has no effect, and they are always read as zeros.
5 downto 0	Frame Store	C_NUM_FSTORES	R/W	<p>Indicates the number of frame stores to use for video data transfers. This value defaults to C_NUM_FSTORES. For Scatter Gather mode (C_INCLUDE_SG = 1) this value specifies the number of Scatter Gather Descriptors required. For Register Direct mode (C_INCLUDE_SG = 0) this value specifies the number of Start Address registers used for transfers. On reset and start-up this register is set to C_NUM_FSTORES.</p> <p>Note: Genlock Masters and their attached Genlock Slaves must have identical Frame Store settings. Any mismatch in values has undefined results.</p> <p>Note: Dynamic Genlock Masters and their attached Dynamic Genlock Slaves must have identical Frame Store settings. Any mismatch in values has undefined results.</p> <p>Note: Values written must be greater than 0 and less than or equal to C_NUM_FSTORES. Any other value has undefined results.</p>

S2MM_THRESHOLD (MM2S Line Buffer Threshold Register – Offset 4Ch) (C_INCLUDE_SG = 1/0)

This register provides the Line Buffer Threshold for the Stream to Memory Map channel.

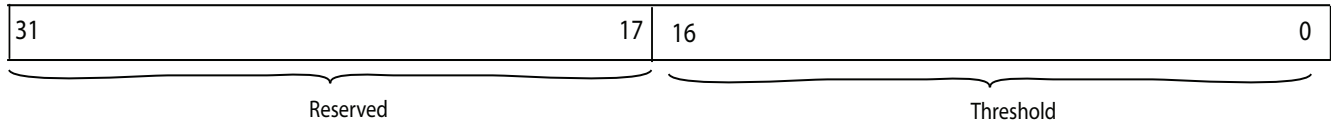

Figure 2-18: S2MM_THRESHOLD Register

Table 2-27: S2MM_THRESHOLD Register Details

Bits	Field Name	Default Value	Access Type	Description																		
31 downto 17	Reserved	zeroes	RO	Always read as zero																		
16 downto 0	Line Buffer Threshold	C_S2MM_LINEBUFFER_THRESH	R/W	<p>Threshold point at which S2MM line buffer almost full flag asserts high.</p> <p>Threshold specified in bytes and must be a multiple of C_S_AXIS_S2MM_TDATA_WIDTH/8, subject to the following condition.</p> <p>When Stream Data Width value is equal to a non-power of 2 value (that is, 24, 40, 72, 136, 264, 520), Threshold follows the restriction impose by the next nearest upper power of 2 value (that is, 32, 64, 128, 256, 512, 1024 respectively).</p> <table border="0"> <tr> <td>Stream Data</td> <td>Width Allowed Values</td> </tr> <tr> <td>8</td> <td>1,2,3,.....</td> </tr> <tr> <td>16</td> <td>2,4,6,.....</td> </tr> <tr> <td>24,32</td> <td>4,8,12,.....</td> </tr> <tr> <td>40 to 64</td> <td>8,16,24,.....</td> </tr> <tr> <td>72 to 128</td> <td>16,32,48,.....</td> </tr> <tr> <td>136 to 256</td> <td>32,64,96,....</td> </tr> <tr> <td>264 to 512</td> <td>64,128,192,...</td> </tr> <tr> <td>520 to 1024</td> <td>128,256,384,..</td> </tr> </table> <p>Note: Maximum threshold value limited by C_S2MM_LINEBUFFER_DEPTH.</p> <p>Note: Value valid when S2MM line buffer is included (C_S2MM_LINEBUFFER_DEPTH > 0).</p>	Stream Data	Width Allowed Values	8	1,2,3,.....	16	2,4,6,.....	24,32	4,8,12,.....	40 to 64	8,16,24,.....	72 to 128	16,32,48,.....	136 to 256	32,64,96,....	264 to 512	64,128,192,...	520 to 1024	128,256,384,..
Stream Data	Width Allowed Values																					
8	1,2,3,.....																					
16	2,4,6,.....																					
24,32	4,8,12,.....																					
40 to 64	8,16,24,.....																					
72 to 128	16,32,48,.....																					
136 to 256	32,64,96,....																					
264 to 512	64,128,192,...																					
520 to 1024	128,256,384,..																					

MM2S Vertical Size (MM2S_VSIZE – Offset 0x50) (C_INCLUDE_SG = 0)

In Register Direct Mode (C_INCLUDE_SG = 0) the vertical size register has a dual purpose: first to hold the number of vertical lines, and second to be the mechanism for starting an MM2S transfer. If MM2S_DMACR.RS = 1, a write to this register transfers the video parameters and start addresses to an internal register block for DMA controller use. This register must be written last for a particular channel.

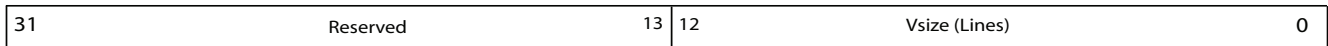

Figure 2-19: MM2S VSIZE Register

Table 2-28: MM2S VSIZE Register Details

Bits	Field Name	Default Value	Access Type	Description
31 downto 13	Reserved	zeros	RO	Writing to these bits has no effect, and they are always read as zeros.
12 downto 0	Vertical Size (Lines)	zeros	R/W	<p>In Register Direct Mode (C_INCLUDE_SG = 0) indicates vertical size in lines of the video data to transfer. There are vsize number of packets that are hsize bytes long transmitted for each frame.</p> <p>In Scatter Gather Mode (C_INCLUDE_SG = 1) this field is reserved and always read as zero.</p> <p>Note: Writing to this register starts the VDMA transfers on MM2S Channel. Valid HSIZE, STRIDE, and Start Addresses must be set prior to writing MM2S_VSIZE or undefined results occur.</p>

MM2S Horizontal Size (MM2S_HSIZE – Offset 0x54) (C_INCLUDE_SG = 0)

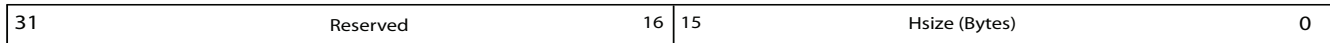

Figure 2-20: MM2S HSIZE Register

Table 2-29: MM2S HSIZE Register Details

Bits	Field Name	Default Value	Access Type	Description
31 downto 16	Reserved	zeros	RO	Writing to these bits has no effect, and they are always read as zeros.
15 downto 0	Horizontal Size (Bytes)	zeros	R/W	In Register Direct Mode (C_INCLUDE_SG = 0) indicates the horizontal size in bytes of the video data to transfer. There are vsize number of packets that are hsize bytes long transmitted for each frame. Note: A value of zero in this field when MM2S_VSIZE is written causes a DMAIntErr to be flagged in the DMASR Register.

MM2S Frame Delay and Stride (MM2S_FRMDLY_STRIDE – Offset 0x58) (C_INCLUDE_SG = 0)

31	Rsvd	29	28	FrmDly	24	23	Reserved	16	15	Stride (Bytes)	0
----	------	----	----	--------	----	----	----------	----	----	----------------	---

Figure 2-21: MM2S Frame Delay and Stride Register

Table 2-30: MM2S FRMDELAY_STRIDE Register Details

Bits	Field Name	Default Value	Access Type	Description
31 downto 29	Reserved	zeroes	RO	Writing to these bits has no effect, and they are always read as zeros.
28 downto 24	Frame Delay	zeros	R/W	In Register Direct Mode (C_INCLUDE_SG = 0) indicates the minimum number of frame stores the Genlock slave is to be behind the locked master. This field is only used if the channel is enabled for Genlock Slave operations (C_MM2S_GENLOCK_MODE = 1). This field has no meaning in other Genlock modes. In Scatter Gather Mode (C_INCLUDE_SG = 1) this field is reserved and always read as zero. Note: Frame Delay must be less than or equal to MM2S_FRMSTORE or undefined results occur.
23 downto 16	Reserved	zeros	RO	Writing to these bits has no effect, and they are always read as zeros.
15 downto 0	Stride (Bytes)	zeros	R/W	In Register Direct Mode (C_INCLUDE_SG = 0) indicates the number of address bytes between the first pixels of each video line. In Scatter Gather Mode (C_INCLUDE_SG = 1) this field is reserved and always read as zero. Note: A stride value less than MM2S_HSIZE causes data to be corrupted.

MM2S Start Addresses (Offsets 0x5C to Maximum Offset 0x98) (C_INCLUDE_SG = 0)

There are C_NUM_FSTORES start addresses for each channel. There is a maximum of 32 start registers available that are divided in two register banks, Bank0 and Bank1, each of 16 registers. Both the banks have the same initial offset (that is, 0x5C) and are accessed depending upon the MM2S_REG_INDEX value. If the user wants to access the 17th start address, it can be done by setting MM2S_REG_INDEX to 1 and accessing offset 0x5C.

31	Start Address 1	0
31	:	0
31	Start Address N ⁽¹⁾	0

1. N = C_NUM_FSTORES

Figure 2-22: MM2S Start Address Register/s 1 to N

Table 2-31: MM2S Start Address Register Details

Bits	Field Name	Default Value	Access Type	Description
31 downto 0 (Offset 0x5C)	Start Address 1	zeros	R/W	In Register Direct Mode (C_INCLUDE_SG = 0) indicates the Start Address for video buffer 1. This is the starting location for video data reads by MM2S. In Scatter Gather Mode (C_INCLUDE_SG = 1) this field is reserved and always read as zero.
31 downto 0 (Offset 0x60 to 0x98 max.)	Start Address 2 to Start Address N	zeros	R/W RO	In Register Direct Mode (C_INCLUDE_SG = 0) and Number of Frame Stores greater than 1 (C_NUM_FSTORES > 1) indicates the Start Addresses for video buffer 2 to video buffer N where N = C_NUM_FSTORES. In Scatter Gather Mode (C_INCLUDE_SG = 1) this field is reserved and always read as zero. Note: Start Address Registers greater than C_NUM_FSTORES are reserved and always read as zero. Note: MM2S_FRMSTORE specifies the number of Start Address registers that are processed.

S2MM Vertical Size (MM2S_VSIZE – Offset 0xA0) (C_INCLUDE_SG = 0)

In Register Direct Mode (C_INCLUDE_SG = 0) the vertical size register has a dual purpose: first to hold the number of vertical lines, and second to be the mechanism for starting an S2MM transfer. If S2MM_DMACR.RS = 1, a write to this register transfers the video parameters and start addresses to an internal register block for DMA controller use. This register must be written last for a particular channel.

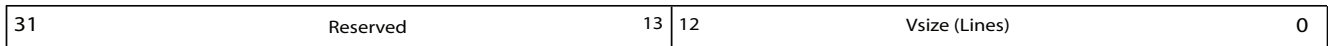

Figure 2-23: S2MM VSIZE Register

Table 2-32: S2MM VSIZE Register Details

Bits	Field Name	Default Value	Access Type	Description
31 downto 13	Reserved	zeros	RO	Writing to these bits has no effect, and they are always read as zeros.
12 downto 0	Vertical Size (Lines)	zeros	R/W	<p>In Register Direct Mode (C_INCLUDE_SG = 0) indicates vertical size in lines of the video data to transfer. There are vsize number of packets that are hsize bytes long transmitted for each frame.</p> <p>In Scatter Gather Mode (C_INCLUDE_SG = 1) this field is reserved and always read as zero.</p> <p>Note: Writing to this register starts the VDMA transfers on S2MM channel. Valid HSIZE, STRIDE and Start Addresses must be set prior to writing S2MM_VSIZE or undefined results occur.</p> <p>Note: Writing a value of zero in this field causes a DMAIntErr to be flagged in the DMASR on next frame boundary.</p>

S2MM Horizontal Size (S2MM_HSIZE – Offset 0xA4) (C_INCLUDE_SG = 0)

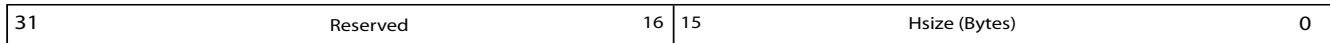

Figure 2-24: S2MM HSIZE Register

Table 2-33: S2MM HSIZE Register Details

Bits	Field Name	Default Value	Access Type	Description
31 downto 16	Reserved	zeros	RO	Writing to these bits has no effect, and they are always read as zeros.
15 downto 0	Horizontal Size (Bytes)	zeros	R/W	<p>In Register Direct Mode (C_INCLUDE_SG = 0) indicates the horizontal size in bytes of the video data to transfer. The S2MM channel is configured to received vsize number of packets that are hsize bytes long for each frame.</p> <p>Note: A value of zero in this field when S2MM_VSIZE is written causes a DMAIntErr to be flagged in the DMASR Register on next frame boundary.</p>

S2MM Frame Delay and Stride (S2MM_FRMDLY_STRIDE – Offset 0xA8) (C_INCLUDE_SG = 0)

31	Rsvd	29	28	S2MM_FrmDly	24	23	Reserved	16	15	S2MM_Stride (Bytes)	0
----	------	----	----	-------------	----	----	----------	----	----	---------------------	---

Figure 2-25: S2MM Frame Delay and Stride Register

Table 2-34: S2MM FRMDELAY_STRIDE Register Details

Bits	Field Name	Default Value	Access Type	Description
31 downto 29	Reserved	zeros	RO	Writing to these bits has no effect, and they are always read as zeros.
28 downto 24	Frame Delay	zeros	R/W	In Register Direct Mode (C_INCLUDE_SG = 0) indicates the minimum number of frame stores the Genlock slave is to be behind the locked master. This field is only used if channel is enabled for Genlock Slave Operations (C_S2MM_GENLOCK_MODE = 1) In Scatter Gather Mode (C_INCLUDE_SG = 1) this field is reserved and always read as zero. Note: Frame Delay must be less than or equal to S2MM_FRMSTORE or undefined results occur.
23 downto 16	Reserved	zeros	R/W	Writing to these bits has no effect, and they are always read as zeros.
15 downto 0	Stride (Bytes)	zeros	R/W	In Register Direct Mode (C_INCLUDE_SG = 0) indicates the number of address bytes between the first pixels of each video line. In Scatter Gather Mode (C_INCLUDE_SG = 1) this field is reserved and always read as zero. Note: A stride value less than S2MM_HSIZE causes data to be corrupted.

S2MM Start Addresses (Offsets 0xAC to Maximum Offset 0xE8) (C_INCLUDE_SG = 0)

There are C_NUM_FSTORES start addresses for each channel. There is a maximum of 32 start registers available that are divided in two register banks, Bank0 and Bank1, each of 16 registers. Both the banks have the same initial offset (that is, 0xE8) and are accessed depending upon the S2MM_REG_INDEX value. If the user wants to access the 17th start address, it can be done by setting S2MM_REG_INDEX to 1 and accessing offset 0xE8.

31	Start Address 1	0
31	:	0
31	Start Address N ⁽¹⁾	0

1. N = C_NUM_FSTORES

Figure 2-26: S2MM Start Address Register/s 1 to N

Table 2-35: S2MM Start Address Register Details

Bits	Field Name	Default Value	Access Type	Description
31 downto 0 (Offset 0xAC)	Start Address 1	zeros	R/W	In Register Direct Mode (C_INCLUDE_SG = 0) indicates the Start Address for video buffer 1. This is the starting location for video data writes by S2MM. In Scatter Gather Mode (C_INCLUDE_SG = 1) this field is reserved and always read as zero.
31 downto 0 (Offset 0xB0 to 0xE8 max.)	Start Address 2 to Start Address N	zeros	R/W RO	In Register Direct Mode (C_INCLUDE_SG = 0) and Number of Frame Stores greater than 1 (C_NUM_FSTORES > 1) indicates the Start Addresses for video buffer 2 to video buffer N where N = C_NUM_FSTORES. In Scatter Gather Mode (C_INCLUDE_SG = 1) this field is reserved and always read as zero. Note: Start Address Registers greater than C_NUM_FSTORES are reserved and always read as zero. Note: S2MM_FRMSTORE specifies the number of Start Address registers that are processed.

**S2MM hsize status Register S2MM_HSIZE_STATUS (offset 0xF0h)
(C_INCLUDE_SG = 0/1)**

This provides hsize count captured when first EOLEarlyErr occurs from incoming stream of S2MM channel. This register gets cleared automatically when S2MM_DMASR[8] is cleared.

Table 2-36: S2MM hsize status Register Details

Bits	Field Name	Default Value	Access Type	Description
31 downto 16	Reserved	0	RO	Writing to these bits has no effect, and they are always read as zeros.
15 downto 0	S2MMHsizeSts	0	RO	Indicates HSIZE count captured at first EOLEarlyErr error for S2MM channel.

**S2MM vsize status Register S2MM_VSIZE_STATUS (offset 0xF4h)
(C_INCLUDE_SG = 0/1)**

This provides vsize count captured when first SOFEarlyErr occurs from incoming stream of S2MM channel. This register gets cleared automatically when S2MM_DMASR[7] is cleared.

Table 2-37: S2MM vsize status Register Details

Bits	Field Name	Default Value	Access Type	Description
31 downto 13	Reserved	0	RO	Writing to these bits has no effect, and they are always read as zeros.
12 downto 0	S2MMVsizeSts	0	RO	Indicates VSIZE count captured at first SOFEarlyErr error for S2MM channel.

Designing with the Core

General Design Guidelines

AXI VDMA is compliant to AXI4 on both the memory and streaming side. Any AXI compliant IP can be connected to the core. See [XAPP741](#), [XAPP742](#) for various system configuration using AXI VDMA. Also see the [Triple Frame Buffer Example](#) at the end of the chapter.

Clocking

AXI VDMA provides two clocking modes of operation: asynchronous and synchronous. In async mode DMA control, Scatter Gather Engine, MM2S and S2MM Primary datapaths can all run asynchronously from each other. Setting `C_PRMRY_IS_ACLK_ASYNC = 1` enables this mode and creates six clock domains.

- AXI4-Lite clock domain clocked by `s_axi_lite_aclk`
- Scatter Gather clock domain clocked by `m_axi_sg_aclk`
- mm2s clock domain on Memory Map side clocked by `m_axi_mm2s_aclk`
- s2mm clock domain on Memory Map side clocked by `m_axi_s2mm_aclk`
- s2mm clock domain on streaming side clocked by `s_axis_s2mm_aclk`
- mm2s clock domain on streaming side clocked by `m_axis_mm2s_aclk`

In asynchronous mode, the frequency of `s_axi_lite_aclk` \leq `m_axi_sg_aclk` \leq `m_axi_mm2s_aclk` or `m_axi_s2mm_aclk`.

In synchronous mode, `C_PRMRY_IS_ACLK_ASYNC = 0`, all logic runs in a single clock domain. The signals `s_axi_lite_aclk`, `m_axi_sg_aclk`, `m_axi_mm2s_aclk`, `m_axi_s2mm_aclk`, `m_axis_mm2s_aclk`, and `s_axis_s2mm_aclk` must be tied to the same source otherwise undefined results occur.

Dynamic Clock Feature

Dynamic Clock changing is supported on the AXI4-Stream. This allows users to dynamically change the stream clocks (`m_axis_mm2s_aclk` and `s_axis_s2mm_clk`) without affecting the AXI Interconnect, AXI Memory controller, and so on.

Limitation

Changing the clock frequency during operation has a system-wide effect. Therefore, system considerations must be addressed to support dynamic clock changing. To fully support dynamic changing of all clocks, the AXI4 Memory Map targets must be able to support dynamic clock changes and the AXI4-Stream targets must be able to support dynamic clock changes. Support for dynamic clock changing on a system level is outside of AXI VDMA control and is beyond the scope of this document. As such dynamic clock changing (changing the clock frequency during run time) of `s_axi_lite_aclk`, `m_axi_sg_aclk`, `m_axi_mm2s_aclk`, and `m_axi_s2mm_aclk` is *not* supported. If during operation a clock change is required on `s_axi_lite_aclk`, `m_axi_sg_aclk`, `m_axi_mm2s_aclk`, or `m_axi_s2mm_aclk` then a system reset is required.

Dynamic Resolution

This feature allows you to dynamically change both the streaming clock and frame format without going through the reset cycle. For example, you will be able to switch between HD1080 to NTSC/PAL without going through reset cycle.

Limitation

The following sequence should be exercised before switching to another frame format

- a. Write `DMACR(0) = 0`.
- b. Poll for `DMASR(0)` to become 1.
- c. Then Write `DMACR(0) = 1`.
- d. Then Write new `HSIZE` & `VSIZE`.

Table 3-1 illustrates signal sets and its corresponding clock in asynchronous mode.

**Table 3-1: Asynchronous Mode Clock Distribution
(C_PRMRY_IS_ACLK_ASYNC = 1)**

Target Clocks	C_INCLUDE_SG = 1	C_INCLUDE_SG = 0
s_axi_lite_aclk	All s_axi_lite_* Signals mm2s_introut s2mm_introut axi_resetrn	All s_axi_lite_* Signals mm2s_introut s2mm_introut axi_resetrn
m_axi_sg_aclk	All m_axi_sg_* Signals	NA
m_axi_mm2s_aclk	All m_axi_mm2s_* Signals mm2s_prmry_reset_out_n	All m_axi_mm2s_* Signals mm2s_prmry_reset_out_n
m_axi_s2mm_aclk	All m_axi_s2mm_* Signals s2mm_prmry_reset_out_n	All m_axi_s2mm_* Signals s2mm_prmry_reset_out_n
m_axis_mm2s_aclk	All m_axis_mm2s_* Signals mm2s_fsync mm2s_fsync_out mm2s_prmtr_update mm2s_frame_ptr_in mm2s_frame_ptr_out mm2s_buffer_empty mm2s_buffer_almost_empty	All m_axis_mm2s_* Signals mm2s_fsync mm2s_fsync_out mm2s_prmtr_update mm2s_frame_ptr_in mm2s_frame_ptr_out mm2s_buffer_empty mm2s_buffer_almost_empty
s_axis_s2mm_aclk	All s_axis_s2mm_* Signals s2mm_fsync s2mm_fsync_out s2mm_prmtr_update s2mm_frame_ptr_in s2mm_frame_ptr_out s2mm_buffer_full s2mm_buffer_almost_full	All s_axis_s2mm_* Signals s2mm_fsync s2mm_fsync_out s2mm_prmtr_update s2mm_frame_ptr_in s2mm_frame_ptr_out s2mm_buffer_full s2mm_buffer_almost_full

Resets

The AXI VDMA uses a single Active-Low reset input signal `axi_resetn`. The reset signal must be synchronous to the `s_axi_lite_aclk` signal and should be asserted for a minimum of eight clock cycles of the slowest clock. This is considered a hard reset and there is no graceful completion of transactions; all registers are reset to power-on conditions; all queues are flushed; all internal logic is returned to power-on conditions.

AXI VDMA also provides Soft Reset with the DMA Control Register for each channel. Issuing a Soft Reset by setting MM2S DMA Control Register Reset bit to 1 or S2MM DMA Control Register Reset bit to 1 causes the respective channel to reset gracefully. Ongoing transfers will complete including any queued transfers. Resetting one channel with the DMA Control Register does *not* Reset the other channel.

AXI VDMA also provides separate reset output signals MM2S Reset Out and S2MM Reset Out on both channels.

Parameter Descriptions

C_PRMRY_IS_ACLK_ASYNC

- **Type:** Integer
- **Allowed Values:** 0,1 (default = 0)
- **Definition:** 0 = `s_axi_lite_aclk`, `m_axi_sg_aclk`, `m_axi_mm2s_aclk`, `m_axis_mm2s_aclk`, `m_axi_s2mm_aclk` and `s_axis_s2mm_aclk` are synchronous to each other; 1 = `s_axi_lite_aclk`, `m_axi_sg_aclk`, `m_axi_mm2s_aclk`, `m_axis_mm2s_aclk`, `m_axi_s2mm_aclk` and `s_axis_s2mm_aclk` are asynchronous to each other.
- **Description:** See [Clocking](#) for more details.

C_DLYTMR_RESOLUTION

- **Type:** Integer
- **Allowed Values:** 1 to 100,000 (default = 125)
- **Definition:** Interrupt Delay Timer Resolution
- **Description:** This integer parameter is used to set the resolution of the Interrupt Delay Timer. Values specify the number of `m_axi_sg_aclk` clock cycles (when `C_INCLUDE_SG=1`) or `s_axi_lite_aclk` clock cycles (when `C_INCLUDE_SG = 0`) between each tick of the delay timer.

C_NUM_FSTORES

- **Type:** Integer
- **Allowed Values:** 1 to 32 (default = 3)
- **Definition:** Maximum number of frame stores
- **Description:** This integer parameter is used to define the maximum number of frame storage locations to be processed by the AXI VDMA. For Scatter Gather Mode (C_INCLUDE_SG = 1), this parameter also defines the maximum number of Scatter Gather descriptors per channel in the descriptor chain required to initialize the AXI VDMA. For Register Direct Mode (C_INCLUDE_SG = 0), this parameter defines the maximum number of buffer Start Address Registers. The actual number of frame store locations used is set by register write to MM2S_FRM_STORE (offset 0x18) or S2MM_FRM_STORE (offset 0x48) register for the associated channel.

C_USE_FSYNC

- **Type:** Integer
- **Allowed Values:** 0, 1, 2, 3 (default = 0)
- **Definition:** 0 = Free run mode, 1 = Both channels in frame sync mode, 2 = Only MM2S channel in frame sync mode, 3 = Only S2MM channel in frame sync mode
- **Description:** This integer parameter is used to set the synchronization mode of AXI VDMA. When in free mode, the AXI VDMA transfers data as quickly as it is able to. When in frame sync mode, the AXI VDMA transfers data starting with the falling edge of each `mm2s_fsync` or `s2mm_fsync` for the associated channel.

C_ENABLE_VIDPRMTR_READS

- **Type:** Integer
- **Allowed Values:** 0, 1 (default =1)
- **Definition:** 0 = Disable Video Parameter Reads, 1 = Enable Video Parameter Reads
- **Description:** This integer parameter is used to enable the read access to the video parameters by the `s_axi_lite` interface when configured for Register Direct Mode. Disabling the video parameter register reads reduces FPGA resource utilization.

C_INCLUDE_INTERNAL_GENLOCK

- **Type:** Integer
- **Allowed Values:** 0,1, (default = 1)
- **Definition:** 0 = Exclude internal Genlock bus, 1 = Include internal Genlock bus
- **Description:** Include or exclude an internal Genlock bus. It allows internal routing of MM2S and S2MM Genlock buses without having it connected outside the core.

C_MM2S_SOF_ENABLE

- **Type:** Integer
- **Allowed Values:** 0,1, (default = 0)
- **Definition:** 0 = Disables SOF generation on `m_axis_mm2s_tuser(0)`, 1 = Enables SOF generation on `m_axis_mm2s_tuser(0)`
- **Description:** SOF pulse is driven on `m_axis_mm2s_tuser(0)` coincident with first pixel of the first line for each frame. For additional information, see the Video IP: AXI Feature Adoption section of the *AXI Reference Guide* ([UG761](#)).

C_S2MM_SOF_ENABLE

- **Type:** Integer
- **Allowed Values:** 0,1, (default = 0)
- **Definition:** 0 = Disables SOF detection on `s_axis_s2mm_tuser(0)`, 1 = Enables SOF detection on `s_axis_s2mm_tuser(0)`
- **Description:** When S2MM channel is in external fsync mode (`C_USE_FSYNC = 1,3`), this setting along with `FsyncSrcSelect = 10`, enables SOF pulse detection on `m_axis_s2mm_tuser(0)`. SOF pulse is coincident with the first pixel of the first line for each frame. For additional information, see the "Video IP: AXI Feature Adoption" section of the *AXI Reference Guide* ([UG761](#)).

C_FLUSH_ON_FSYNC

- **Type:** Integer
- **Allowed Values:** 0, 1, 2, 3 (default = 1)
- **Definition:** 0 = No flush/reset on frame sync on any channel, 1 = Flush/reset on frame sync on both channels, 2 = Flush/reset on frame sync on MM2S channel but not on S2MM channel, 3 = Flush/reset on frame sync on S2MM channel but not on MM2S channel
- **Description:** Specifies when VDMA channel transactions are flushed and channel states are reset on frame sync.

C_S_AXI_LITE_ADDR_WIDTH

- **Type:** Integer
- **Allowed Values:** 9 (default = 9)
- **Definition:** Address bus width of attached AXI on the AXI4-Lite interface
- **Description:** This integer parameter is used by the AXI4-Lite interface to size the AXI read and write address bus related components within the Lite interface.

C_S_AXI_LITE_DATA_WIDTH

- **Type:** Integer
- **Allowed Values:** 32 (default = 32)
- **Definition:** Data bus width of attached AXI on the AXI4-Lite interface
- **Description:** This integer parameter is used by the AXI4-Lite interface to size the AXI read and write data bus related components within the Lite interface.

C_INCLUDE_SG

- **Type:** Integer
- **Allowed Values:** 0,1 (default = 0)
- **Definition:** 0 = Exclude SG Engine; 1 = Include SG Engine
- **Description:** Include or exclude Scatter Gather Engine. Setting this parameter to 0 causes all output ports for the Scatter Gather engine to be tied to zero and all of the input ports to be left open. Excluding the Scatter Gather engine configures the AXI VDMA for Register Direct Mode.

C_M_AXI_SG_DATA_WIDTH

- **Type:** Integer
- **Allowed Values:** 32 (default = 32)
- **Definition:** Data bus width of attached AXI on the AXI Scatter Gather interface
- **Description:** This integer parameter is used by the AXI Scatter Gather interface to size the AXI read data bus related components within the Scatter Gather Engine.

C_M_AXI_SG_ADDR_WIDTH

- **Type:** Integer
- **Allowed Values:** 32 (default = 32)
- **Definition:** Address bus width of attached AXI on the AXI Scatter Gather interface
- **Description:** This integer parameter is used by the AXI Scatter Gather interface to size the AXI read address bus related components within the Scatter Gather Engine.

C_INCLUDE_MM2S

- **Type:** Integer
- **Allowed Values:** 0,1 (default = 1)
- **Definition:** 0 = Exclude MM2S Channel; 1 = Include MM2S Channel
- **Description:** Include or exclude MM2S Channel. Setting this parameter to 0 causes all output ports for the MM2S channel to be tied to zero and all of the input ports for the respective channel to be left open.

Note: Setting both C_INCLUDE_MM2S = 0 and C_INCLUDE_S2MM = 0 disables all logic within the AXI VDMA and is not a valid configuration.

C_INCLUDE_S2MM

- **Type:** Integer
- **Allowed Values:** 0,1 (default = 1)
- **Definition:** 0 = Exclude S2MM Channel; 1 = Include S2MM Channel
- **Description:** Include or exclude S2MM Channel. Setting this parameter to 0 causes all output ports for the S2MM channel to be tied to zero, and all of the input ports for the respective channel to be left open.

Note: Setting both C_INCLUDE_MM2S = 0 and C_INCLUDE_S2MM = 0 disables all logic within the AXI VDMA and is not a valid configuration.

C_INCLUDE_MM2S_DRE

- **Type:** Integer
- **Allowed Values:** 0,1 (default = 0)
- **Definition:** 0 = Exclude MM2S Data Realignment Engine; 1 = Include MM2S Data Realignment Engine
- **Description:** Include or exclude MM2S Data Realignment Engine.

When `C_INCLUDE_MM2S_DRE = 1`, data reads can start from any Start Address byte offset, be of any horizontal size and stride value and the read data are aligned such that the first byte read is the first valid byte out on the AXI4-Stream.

When `C_INCLUDE_MM2S_DRE = 0`, the Start Address must be aligned to multiples of `C_M_AXI_MM2S_DATA_WIDTH` bytes. Also Horizontal Size and Stride must be specified in even multiples of `C_M_AXI_MM2S_DATA_WIDTH` bytes.

Note: If DRE is disabled (`C_INCLUDE_MM2S_DRE = 0`), unaligned Start Address, HSize, and/or Stride results in undefined behavior.

Note: DRE support is only available for AXI4-Stream data width setting of 64-bits and less.

C_INCLUDE_S2MM_DRE

- **Type:** Integer
- **Allowed Values:** 0,1 (default = 0)
- **Definition:** 0 = Exclude S2MM Data Realignment Engine, 1 = Include S2MM Data Realignment Engine
- **Description:** Include or exclude S2MM Data Realignment Engine.

When `C_INCLUDE_S2MM_DRE = 1`, data writes can start from any Start Address byte offset, be of any horizontal size and stride value and the write data are aligned such that first valid byte in on the AXI4-Stream is the byte written to the memory location specified by the Start Address, Hsize, and Stride.

When `C_INCLUDE_S2MM_DRE = 0`, then the Start Address must be aligned to multiples of `C_M_AXI_S2MM_DATA_WIDTH` bytes. Also Horizontal Size and Stride must be specified in even multiples of `C_M_AXI_S2MM_DATA_WIDTH` bytes.

Note: If DRE is disabled (`C_INCLUDE_S2MM_DRE = 0`), unaligned Start Address, HSize, and/or Stride results in undefined behavior. DRE support is only available for AXI4-Stream data width setting of 64-bits and under.

C_INCLUDE_MM2S_SF

- **Type:** Integer
- **Allowed Values:** 0,1 (default = 1)
- **Definition:** 0 = Exclude MM2S Store-And-Forward; 1 = Include MM2S Store-And-Forward
- **Description:** Include or exclude MM2S Store-And-Forward buffer. When included, a Store-And-Forward buffer and manager are instantiated in AXI VDMA preventing the MM2S channel from requesting more read data than can be held in the Store-And-Forward buffer. Store-And-Forward depth is internally calculated as the next power of two greater than $6 \times C_MM2S_MAX_BURST_LENGTH$.

If both the MM2S Line Buffer and the Store-And-Forward buffer are included then `m_axis_mm2s_tvalid` does not assert high until the set line buffer threshold, `C_MM2S_LINEBUFFER_THRESH`, is met.

When excluded, no Store-And-Forward buffer is instantiated and as soon as data is read by AXI VDMA, `m_axis_mm2s_tvalid` asserts. Also read requests by AXI VDMA are made as quickly as possible.

Store-And-Forward buffer is enabled automatically if `C_M_AXI_MM2S_DATA_WIDTH` and `C_M_AXIS_MM2S_TDATA_WIDTH` are different.

C_INCLUDE_S2MM_SF

- **Type:** Integer
- **Allowed Values:** 0,1 (default = 1)
- **Definition:** 0 = Exclude S2MM Store-And-Forward; 1 = Include S2MM Store-And-Forward
- **Description:** This parameter is enabled always in S2MM path. This parameter is redundant and will be removed in later versions.

C_MM2S_GENLOCK_MODE

- **Type:** Integer
- **Allowed Values:** 0, 1, 2, 3 (default = 1)
- **Definition:** 0 = Genlock Master Mode, 1 = Genlock Slave Mode, 2 = Dynamic Genlock Master Mode, 3 = Dynamic Genlock Slave Mode
- **Description:** This integer parameter sets the MM2S Channel Genlock synchronization mode. See [Genlock Synchronization](#) for more details.

C_S2MM_GENLOCK_MODE

- **Type:** Integer
- **Allowed Values:** 0, 1, 2, 3 (default = 0)
- **Definition:** 0 = Genlock Master Mode, 1 = Genlock Slave Mode, 2 = Dynamic Genlock Master Mode, 3 = Dynamic Genlock Slave Mode
- **Description:** This integer values sets the S2MM channel Genlock synchronization mode. See [Genlock Synchronization](#) for more details.

C_MM2S_GENLOCK_NUM_MASTERS

- **Type:** Integer
- **Allowed Values:** 1 to 16(default = 1)
- **Definition:** Number of masters to which the slave synchronizes operations.
- **Description:** This integer parameter specifies the following:
 - For Genlock Slave, it specifies the number of Masters to which this Slave can synchronize.
 - For Dynamic Genlock Master, it specifies the number of Dynamic Genlock Slave can synchronize.
 - For Dynamic Genlock Slave, it specifies the number of Dynamic Genlock Master can synchronize.
 - This parameter also specifies the vector width of the `mm2s_frm_ptr_in` port, where each master requires 5 bits on the `mm2s_frm_ptr_in` vector. Therefore, the width of the `mm2s_frm_ptr_in` port is $6 * C_MM2S_GENLOCK_NUM_MASTERS$.

Note: This parameter is not valid in Genlock Master mode(`C_MM2S_GENLOCK_MODE = 0`)

C_S2MM_GENLOCK_NUM_MASTERS

- **Type:** Integer
- **Allowed Values:** 1 to 16 (default = 1)
- **Definition:** Number of masters to which the slave synchronizes operations.
- **Description:** This integer parameter specifies the following:
 - For Genlock Slave, it specifies the number of Masters to which this Slave can synchronize.
 - For Dynamic Genlock Master, it specifies the number of Dynamic Genlock Slave can synchronize.
 - For Dynamic Genlock Slave, it specifies the number of Dynamic Genlock Master can synchronize.
 - This parameter also specifies the vector width of the `mm2s_frm_ptr_in` port, where each master requires 5 bits on the `s2mm_frm_ptr_in` vector. Therefore, the width of the `mm2s_frm_ptr_in` port is $6 * C_S2MM_GENLOCK_NUM_MASTERS$.

Note: This parameter is not valid in Genlock Master mode(`C_S2MM_GENLOCK_MODE = 0`)

C_MM2S_GENLOCK_REPEAT_EN

- **Type:** Integer
 - **Allowed Values:** 0 to 1(default = 1)
 - **Definition:** 0 = Frame is advanced, 1 = Frame is repeated
 - **Description:** Specifies if an errored frame is repeated on the next frame sync or if the frame is advanced to the next frame
- Note:** This parameter is only valid for Genlock Slave mode (C_MM2S_GENLOCK_MODE = 0,2) with C_USE_FSYNC=1,2 and C_FLUSH_ON_FSYNC=1,2.

C_S2MM_GENLOCK_REPEAT_EN

- **Type:** Integer
 - **Allowed Values:** 0 to 1(default = 0)
 - **Definition:** 0 = Frame is advanced, 1 = Frame is repeated
 - **Description:** Specifies if an errored frame is repeated on the next frame sync or if the frame is advanced to the next frame.
- This parameter is only valid for Genlock Slave mode (C_S2MM_GENLOCK_MODE = 0,2) with C_USE_FSYNC=1,3 and C_FLUSH_ON_FSYNC=1,3.

C_S_AXI_MM2S_ADDR_WIDTH

- **Type:** Integer
- **Allowed Values:** 32 (default = 32)
- **Definition:** Address bus width of attached AXI on the AXI MM2S Memory Map Read interface
- **Description:** This integer parameter is used by the MM2S interface to size the AXI read address bus-related components within the MM2S Channel. The EDK tool suite assigns this parameter a fixed value of 32.

C_M_AXI_MM2S_DATA_WIDTH

- **Type:** Integer
- **Allowed Values:** 32, 64, 128, 256, 512, 1024 (default = 32)
- **Definition:** Data bus width of AXI on the AXI MM2S Memory Map Read interface
- **Description:** This integer parameter is used by the MM2S interface to size the AXI read data bus related components within the MM2S Channel. The EDK tools ensure correct sizing of the AXI data width based on EDK system configuration.

C_M_AXIS_MM2S_TDATA_WIDTH

- **Type:** Integer
- **Allowed Values:** Supports multiples of 8 bit widths; Min = 8; Max = 1024 (default = 32)
- **Definition:** Data bus width of AXI on the AXI MM2S Master Stream interface
- **Description:** This integer parameter is used by the MM2S interface to size the AXI Master Stream data bus-related components within the MM2S Channel.
Note: This parameter must be set less than or equal to C_M_AXI_MM2S_DATA_WIDTH.

C_M_AXI_S2MM_ADDR_WIDTH

- **Type:** Integer
- **Allowed Values:** 32 (default = 32)
- **Definition:** Address bus width of AXI on the AXI S2MM Memory Map Write interface
- **Description:** This integer parameter is used by the S2MM interface to size the AXI write address bus-related components within the S2MM Channel. The EDK tool suite assigns this parameter a fixed value of 32.

C_M_AXI_S2MM_DATA_WIDTH

- **Type:** Integer
- **Allowed Values:** 32, 64, 128, 256, 512, 1024 (default = 32)
- **Definition:** Data bus width of AXI on the AXI S2MM Memory Map Write interface
- **Description:** This integer parameter is used by the S2MM interface to size the AXI write data bus-related components within the S2MM channel. The EDK tools ensure correct sizing of the AXI data width based on the EDK system configuration.

C_S_AXIS_S2MM_TDATA_WIDTH

- **Type:** Integer
- **Allowed Values:** Supports multiples of 8 bit widths; Min = 8; Max = 1024 (default = 32)
- **Definition:** Data bus width of AXI on the AXI S2MM Slave Stream interface
- **Description:** This integer parameter is used by the S2MM interface to size the AXI Slave Stream data bus related components within the S2MM Channel.
Note: This parameter must be set less than or equal to C_M_AXI_S2MM_DATA_WIDTH.

C_MM2S_MAX_BURST_LENGTH

- **Type:** Integer
- **Allowed Values:** 16, 32, 64, 128, 256 (default = 16)
- **Definition:** MM2S maximum burst length in data beats
- **Description:** Maximum burst length of the MM2S memory map interface. This parameter sets the granularity of burst partitioning. For example, if the burst length is set to 16, the maximum burst on the memory map interface will be 16 data beats. Smaller values reduce throughput but result in less impact on the AXI infrastructure. Larger values increase throughput but result in a greater impact on the AXI infrastructure.

C_S2MM_MAX_BURST_LENGTH

- **Type:** Integer
- **Allowed Values:** 16, 32, 64, 128, 256 (default = 16)
- **Definition:** S2MM maximum burst length in data beats
- **Description:** Maximum burst length of the S2MM memory map interface. This parameter sets the granularity of burst partitioning. For example, if the burst length is set to 16, the maximum burst on the memory map interface is 16 data beats. Smaller values reduce throughput but result in less impact on the AXI infrastructure. Larger values increase throughput but result in a greater impact on the AXI infrastructure.

C_MM2S_LINEBUFFER_DEPTH

- **Type:** Integer
- **Allowed Values:** 0, 1, 2, 4, 8, 16, 32, 64, 128, 256, 512, 1024, 2048, 4096, 8192, 16384, 32768, 65536 (default = 128)
- **Definition:** MM2S line buffer depth
- **Description:** Depth of Line Buffer FIFO. Depth specified in bytes. Depth parameter must be a power of 2 value, that is, 1, 2, 4, 8, 16,...1024, 2048, and so on. The valid minimum depth, excluding 0, equals $C_M_AXIS_MM2S_TDATA_WIDTH/8$; it must always be a power of 2 value. In case this division produces a non-power of 2 value, the allowed minimum depth is the nearest upper power of 2 value.

Stream Data Width	Allowed Values
8	1, 2, 4,.....65536
16	2, 4, 8,.....65536
24, 32	4, 8, 16,.....65536
40 to 64	8, 16, 32,.....65536
72 to 128	16, 32, 64,.....65536
136 to 256	32, 64, 128,.....65536
264 to 512	64, 128, 256,....65536
520 to 1024	128, 256, 512,...65536

Note: A value of zero will exclude the line buffer.

C_S2MM_LINEBUFFER_DEPTH

- **Type:** Integer
- **Allowed Values:** 0, 1, 2, 4, 8, 16, 32, 64, 128, 256, 512, 1024, 2048, 4096, 8192, 16384, 32768, 65536 (default = 128)
- **Definition:** S2MM line buffer depth
- **Description:** Depth of Line Buffer FIFO. Depth specified in bytes. Depth parameter must be a power of 2 value, that is, 1, 2, 4, 8, 16,...1024, 2048, and so on. The valid minimum depth, excluding 0, equals $C_S_AXIS_S2MM_TDATA_WIDTH/8$; it must always be a power of 2 value. In case this division produces a non-power of 2 value, the allowed minimum depth is the nearest upper power of 2 value.

Stream Data Width	Allowed Values
8	1, 2, 4,.....65536
16	2, 4, 8,.....65536
24, 32	4, 8, 16,.....65536
40 to 64	8, 16, 32,.....65536
72 to 128	16, 32, 64,.....65536
136 to 256	32, 64, 128,.....65536
264 to 512	64, 128, 256,....65536
520 to 1024	128, 256, 512,...65536

Note: A value of zero will exclude the line buffer.

C_MM2S_LINEBUFFER_THRESH

- **Type:** Integer
- **Allowed Values:** 1 to 65536 (default = 4)
- **Definition:** MM2S line buffer almost empty threshold in bytes
- **Description:** Almost Empty Threshold. Sets the default threshold point at which the MM2S line buffer almost empty flag asserts high. The threshold can be modified dynamically during run time by writing to the MM2S_THRESHOLD register. The threshold is specified in bytes and must be multiple of C_M_AXIS_MM2S_TDATA_WIDTH/8. If C_M_AXIS_MM2S_TDATA_WIDTH is a non power of 2, the line buffer threshold value should be calculated based on the nearest upper power of 2 value.

For example if C_M_AXIS_MM2S_TDATA_WIDTH = 24, the threshold values should be calculated based on nearest upper power of 2. That is, C_M_AXIS_MM2S_TDATA_WIDTH = 32.

The following table illustrates the stream data width and its corresponding allowed line buffer threshold values

Stream Data Width	Allowed Values
8	1, 2, 3,.....
16	2, 4, 6,.....
24, 32	4, 8, 12,.....
40 to 64	8, 16, 24,.....
72 to 128	16, 32, 48,.....
136 to 256	32, 64, 96,.....
264 to 512	64, 128, 192,.....
520 to 1024	128, 256, 384,.....

On power up and reset, the MM2S_THRESHOLD Register (Offset 0x1C) is set to this value.

Note: The maximum threshold value is limited by C_MM2S_LINEBUFFER_DEPTH

C_S2MM_LINEBUFFER_THRESH

- **Type:** Integer
- **Allowed Values:** 1 to 65536 (default = 4)
- **Definition:** S2MM line buffer almost full threshold in bytes
- **Description:** Almost Full Threshold. Sets the default threshold point at which the MM2S line buffer almost full flag asserts high. Threshold can be modified dynamically during run time by writing to the S2MM_THRESHOLD register. The threshold is specified in bytes and must be multiple of C_S_AXIS_S2MM_TDATA_WIDTH/8. If C_S_AXIS_S2MM_TDATA_WIDTH is a non-power of 2, the line buffer threshold value should be calculated based on the nearest upper power of 2 value.

For example, if C_S_AXIS_S2MM_TDATA_WIDTH = 24, the threshold values should be calculated based on the nearest upper power of 2, that is, C_S_AXIS_S2MM_TDATA_WIDTH = 32.

The following table illustrates the stream data width and its corresponding allowed line buffer threshold values

Stream Data Width	Allowed Values
8	1, 2, 3,.....
16	2, 4, 6,.....
24, 32	4, 8, 12,.....
40 to 64	8, 16, 24,.....
72 to 128	16, 32, 48,.....
136 to 256	32, 64, 96,.....
264 to 512	64, 128, 192,.....
520 to 1024	128, 256, 384,.....

On power up and reset, the S2MM_THRESHOLD Register (Offset 0x4C) is set to this value.

Note: The maximum threshold value is limited by C_S2MM_LINEBUFFER_DEPTH.

C_DYNAMIC_RESOLUTION

- **Type:** Integer
- **Allowed Values:** 0 or 1 (default = 1)
- **Definition:** 0 - Disable shadow registers; 1 - Enable shadow registers
- **Description:** This parameter provides an option to disable shadow registers which helps in resource savings. It can be set to 0 where the dynamic resolution change feature is not required. AXI VDMA is backward compatible when its set to default value.

Core Implementation

Functional Simulation

VHDL and Verilog source files for `axi_vdma` are provided un-encrypted for use in behavioral simulation within a simulation environment. Neither a test bench nor test fixture is provided with the AXI VDMA core.

Synthesis

Synthesis of the AXI VDMA can be performed with XST.

When using ISE® Design Suite Project Navigator, the Library for Verilog Sources for AXI VDMA needs to be set to `axi_vdma`. This is done from the ISE Design Suite Project Navigator GUI on the Design tab by right-clicking on **Synthesize - XST**. Then select **Process Properties...** from the pop-up window. At the bottom of the dialog box, set the Property display level to 'Advanced' by selecting it from the drop-down menu. Finally under the Synthesis Options category, find the Property Name 'Library for Verilog Sources' and enter a value of `axi_vdma`.

Xilinx Tools

See [IP Facts](#) for a list of tested design tools.

Static Timing Analysis

Static timing analysis can be performed using *trce*, following *ngdbuild*, *map*, and *par*.

Programming Sequence

Register Direct Mode (`C_INCLUDE_SG = 0`)

VDMA operations in register direct mode begin with the set up of the video parameter and start address registers and the DMA control registers. The following lists minimum steps, in order, required to start AXI VDMA operations:

1. Write control information to channel's DMACR register (Offset 0x00 for MM2S and 0x30 for S2MM) to set interrupt enables if desired, frame count, delay count if desired, and set `DMACR.RS=1` to start the AXI VDMA channel running. There can be a lag between when the CPU sets `DMACR.RS=1` and when AXI VDMA sets `DMASR.Halted = 0`. The CPU can determine if the AXI VDMA is running when `DMACR.RS = 1` and `DMASR.Halted = 0`.

2. Write valid video frame buffer start address to the channel's `START_ADDRESS` register 1 to N where N equals `C_NUM_FSTORES` (Offset 058 up to 0x98 for MM2S and 0xAC up to 0xE8 for S2MM). Set the `REG_INDEX` register as and if required.
3. Write a valid Frame Delay and Stride to the channel `FRMDLY_STRIDE` register (Offset 0x58 for MM2S and 0xA8 for S2MM).
4. Write a valid Horizontal Size to the channel `HSIZE` register (Offset 0x54 for MM2S and 0xA4 for S2MM).
5. Finally write a valid Vertical Size to the channel `VSIZE` register (Offset 0x50 for MM2S and 0xA0 for S2MM). This starts the channel transferring video data.



IMPORTANT: *On the S2MM channel, new video line size and number of video lines need to change following the assertion of `s2mm_prmtr_update` or undefined results occur.*

Updating Video Transfer Information

In Register Direct Mode (`C_INCLUDE_SG = 0`), the user should be able to update video parameter settings at any time while the engine is running by writing new video parameters and a video start address through the AXI4-Lite control interface. The newly written video transfer values take effect on the next frame boundary after the user writes the vertical size register for the respective channel.

The channel's `prmtr_update` output (`mm2s_prmtr_update` and `s2mm_prmtr_update`) for the respective channel asserts, indicating the new video parameters are being used by the AXI VDMA.

To update video parameters dynamically while AXI VDMA operations are ongoing, a similar process to the start steps is needed.

1. Write the Frame Delay, Stride, and Horizontal Size in any order for the associated channel.
2. Finally, write the Vertical Size. When `VSize` is written, the video register values are transferred to an internal register block. On the next frame boundary the DMA controller for the associated channel starts transfers using the newly updated values.

For applications where reading of the video parameters and start address registers is not needed, the FPGA resources can be reduced by excluding the read logic for the video specific registers (`VSIZE`, `HSIZE`, `FRMDLY_STRIDE`, and `START ADDRESS/ES`). This is accomplished by setting `C_ENABLE_VIDPRMTR_READS = 0`.

Scatter Gather Mode (C_INCLUDE_SG = 1)

AXI VDMA operation requires a memory-resident data structure that holds the list of DMA operations to be performed. This list of instructions is organized into what is referred to as a descriptor chain. Each descriptor has a pointer to the next descriptor to be processed. The last descriptor in the chain then points back to the first descriptor in the chain.

VDMA operations began with the setup of the descriptor pointer registers and the DMA control registers. The following lists minimum steps, in order, required for AXI VDMA operations:

1. Write a valid pointer to the channel CURDESC_PNTR register (Offset 0x08 for MM2S and 0x38 for S2MM).
2. Write control information to channel DMACR register (Offset 0x00 for MM2S and 0x30 for S2MM) to set interrupt enables if desired, frame count, delay count if desired, and set DMACR.RS=1 to start the AXI VDMA channel running. There can be a lag between when the CPU sets DMACR.RS=1 and when AXI VDMA sets DMASR.Halted = 0. The CPU can determine if the AXI VDMA is running when DMACR.RS = 1 and DMASR.Halted = 0.
3. Write a valid pointer to the channel TAILDESC_PNTR register (Offset 0x10 for MM2S and 0x40 for S2MM). This starts the channel fetching and processing descriptors.
4. DMA scatter gather operations continue until the descriptor at TAILDESC_PNTR is processed, and then the engine idles as indicated by DMASR.Idle = 1.

The descriptor chain is made up of a maximum of C_NUM_FSTORES descriptors per channel. The SG Engine fetches descriptors and updates an internal register set with the descriptor information. The video timing information (vsize, hsize, stride, and frame delay) from the first descriptor fetched is captured and stored.

This video timing information is used for all transfers in all frames for the specified channel. All other video timing information in the other descriptors is ignored by the AXI VDMA. Start Addresses from each descriptor are populated into C_NUM_FSTORES internal address registers.

When the SG Engine reaches the descriptor pointed to by TAILDESC, the SG Engine processes that descriptor, sets the internal register set to ping-pong on the next frame sync (Internally generated if C_USE_FSYNC = 0 or externally if C_USE_FSYNC = 1,2,3), and enters an Idle state. At the next frame sync, the internal register set will switch such that the DMA controller operates on the newly updated values.

This method for handling data updates internally allows the SG engine to operate on a register set without stepping on the register set that the DMA controller is using for data transfers. It also allows the SG Engine to only fetch descriptors when a change is made to the data set, making it unnecessary for the SG engine to fetch a descriptor with each frame. The DMA controller continues to transfer video data even though the SG engine has reached the tail pointer and paused. This allows uninterrupted video data transfers.

Updating Video Transfer Information

To update the video transfer information for a channel, the CPU writes a new start address, vsize, hsize, stride, and frame delay information into the descriptor following the TAILDESC position. Then the CPU writes a new TAILDESC pointing to this newly updated descriptor. The SG Engine automatically fetches the newly updated descriptor and updates the start address, vsize, hsize, stride, and frame delay to the internal SG labeled register block. On the next frame sync for the channel these newly updated values are transferred to the Video labeled register block for use by the channel DMA controller. The outputs, `mm2s_prmtr_update` and `s2mm_prmtr_update`, for the respective channel asserts coincident with `mm2s_fsync` and `s2mm_fsync` respectively when the new parameters take effect for the channel.



IMPORTANT: *On the S2MM channel, new video line size and number of video lines need to change following the assertion of `s2mm_prmtr_update` or undefined results occur.*

The CPU should only update the TAILDESC when the engine is Idle; otherwise, undefined results occur. Updating the TAILDESC register when the SG Engine is Idle ensures that video timing information is not ignored in the descriptor.

The AXI VDMA Scatter Gather engine has independent descriptor queues for fetch descriptors for the MM2S and S2MM channels. Independent register sets and DMA controllers for MM2S and S2MM channels are also provided.

AXI VDMA General Operations

AXI VDMA Frame Boundary

A frame boundary depends on the mode of operation. For external fsync mode the frame boundary is based on the channel fsync input, `mm2s_fsync` or `s2mm_fsync`. AXI VDMA starts the transfer for a particular frame after driving out an `fsync_out` for the associated channel (`mm2s_fsync_out` or `s2mm_fsync_out`). There is some pipeline delay between the fsync input and when `fsync_out` is driven.

For free run mode (`C_USE_FSYNC = 0`) an internal fsync is generated for timing transfers. AXI VDMA transfers the commanded transfers as quickly as it is able to process and transfer the data. AXI VDMA will drive out an `fsync_out` for the associated channel, `mm2s_fsync_out` or `s2mm_fsync_out`, on each frame boundary.

In S2MM channel, at the end of each frame, when all expected data are received, AXI VDMA continues to assert `s_axis_s2mm_tready` to avoid hang condition when `C_USE_FSYNC=1,3` and `C_FLUSH_ON_FSYNC=1,3`. It also sets appropriate error bits as mentioned in [Table 3-12](#) and [Table 3-13](#).

When new video parameters have been updated to AXI VDMA and the associated channel starts operating on the new video parameters and start addresses, AXI VDMA asserts `mm2s_prmtr_update` or `s2mm_prmtr_update`, coincident with `fsync_out` for the associated channel. This indicates to the attached video IP that new line length and/or line number is in effect.



RECOMMENDED: It creates a deadlock scenario in S2MM channel if Streaming Master waits for `s2mm_prmtr_update` to assert before driving `s_axis_s2mm_tvalid` when `TUSER(0)` is used as SOF. It is because AXI VDMA expects `TUSER(0)` to be asserted to drive `s2mm_prmtr_update`. Hence it is recommended for Streaming Master not to depend on `s2mm_prmtr_update` to start the transfer.

AXI VDMA Video Transfer

Data is transferred from System Memory to Stream or Stream to System Memory as defined by the Start Address for the frame currently being operated on and the vertical size, horizontal size, and stride. Figure 3-1 illustrates a typical video image stored in system memory. The smaller portion of the video image is to be transferred. Vertical Size lines of Horizontal Size number of bytes are transferred from or to system memory starting at each start address for each video frame.

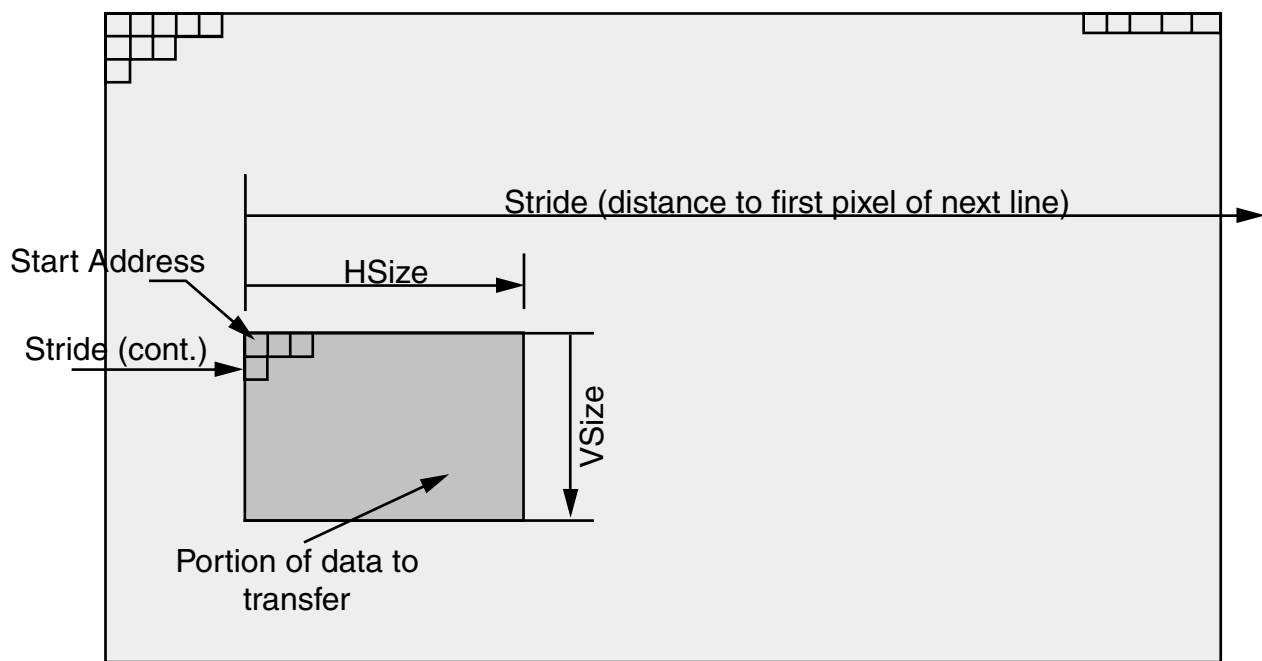

Frame of Image Data

X12150

Figure 3-1: Example Video Image Transfer

Free Run Mode (C_USE_FSYNC = 0)

In free run mode (C_USE_FSYNC = 0), video data are transferred as quickly as possible. The output ports `mm2s_fsync_out` and `s2mm_fsync_out` indicate the frame boundaries. On start-up, that is, DMACR.RS set to 1 for the respective channel, an initial frame sync (`mm2s_fsync_out` or `s2mm_fsync_out`) asserts after the video parameters have been updated. This initial assertion of frame sync indicates the beginning of the first frame. For the MM2S channel, video data for a frame is transferred after the assertion of each `mm2s_fsync_out`. For the S2MM channel, `axi_vdma` expects new data for the frame to be transferred to the `s2mm` channel after the assertion of `s2mm_fsync_out`.

Frame Sync Mode (C_USE_FSYNC = 1,2,3)

In frame sync mode, video data is synchronized to an external frame sync, `mm2s_fsync` for the MM2S channel and `s2mm_fsync` for the S2MM channel. The `axi_vdma` channel begins each frame on the falling edge of the associated channel frame sync input, `mm2s_fsync` or `s2mm_fsync`. For the MM2S channel, data is driven out on the Master AXI4-Stream port following the assertion of `mm2s_fsync`. It is the responsibility of the target video IP to accept all transferred video lines before the assertion of the next `mm2s_fsync` or undefined results occur. For the S2MM channel, data is accepted on the Slave AXI4-Stream port following the assertion of `s2mm_fsync`.

Note: See [S2MM_DMOCR \(S2MM DMA Control Register – Offset 30h\) \(C_INCLUDE_SG = 1/0\)](#) for different sources of `fsync` for S2MM path.

Genlock Synchronization

In many video applications, a producer of data runs at a different rate than the consumer of that data. To avoid the potential ill effects that such a rate mismatch can cause, frame buffering is often used. Frame buffering allocates multiple frames worth of memory to be used to hold the data. The data producer writes to one buffer while the consumer reads from another.

The AXI VDMA supports the following four modes of genlock synchronization.

- **Genlock Master:** Frames are not dropped or repeated. `mm2s_frm_ptr_out` and `s2mm_frm_ptr_out` outputs the current frame number that the Master is being worked on by the MM2S and S2MM channels respectively. The Master does not know the status of the Genlocked Slave. There is a possibility of the Master stepping on to the Slave buffer if the Frame Delay settings in `MM2S_FRMDLY_STRIDE[28:24]` for MM2S channel and `S2MM_FRMDLY_STRIDE[28:24]` for S2MM channel are not managed properly.
- **Genlock Slave:** The Slave tries to catch up with the Genlock Master either by dropping or repeating frames. It samples the Genlocked Master frame number on `mm2s_frm_ptr_in` and operates with Frame Delay behind the Master. The Slave does not outputs its current frame number on `mm2s_frm_ptr_out`.

- **Dynamic Genlock Master:** In this mode, the Master dynamically skips the frame buffers that the Slave is operating on. The Master outputs the previously accessed frame pointer on `mm2s_frm_ptr_out` for the MM2S channel and `s2mm_frm_ptr_out` for the S2MM channel. It also samples `m2s_frm_ptr_in` for the MM2S channel and `s2mm_frm_ptr_out` for the S2MM channel that contains the frame number that the Dynamic Genlocked Slave is operating on to avoid stepping over.

Example: In case of three frame stores, the Dynamic Genlock Master will rotate around 0,1,2,0,1,2 and so on as long as it is not stepping on the Slave buffer. If it does detect that it is stepping on the Slave buffer, it skips that buffer and keeps on rotating. Thus if the Slave buffer is 1 for a long time, the Master rotates between 0,2,0,2 and so on. If `C_GENLOCK_REPEAT_EN = 1`, the Master retains the previous frame pointer output in case of error-ed frame.

- **Dynamic Genlock Slave:** In this mode, the Slave operates on the frame number that the Dynamic Genlocked Master is outputting. Frame Delay is not valid in Dynamic Genlock modes. The Slave also drives its current accessed frame number on `mm2s_frm_ptr_out` and `s2mm_frm_ptr_out` for the MM2S and S2MM channels respectively.

Note: The Dynamic Genlock Master should be Genlocked only with the Dynamic Genlock Slave to have meaningful results.

The genlock mode for the AXI VDMA is enabled by setting `MM2S_DMACR` bit[3](GenlockEn) or `S2MM_DMACR` bit[3](GenlockEn). This setting has no effect for the Genlock Master. Genlocked Slave or Dynamic Genlocked Slave can also become synchronized to multiple Genlocked Masters or Dynamic Genlocked Masters based on the register settings in `MM2S_DMACR`[11:8] and `S2MM_DMACR`[11:8] for MM2S and S2MM channels respectively. If the internal genlock mode is enabled (`C_INCLUDE_INTERNAL_GENLOCK = 1`, `MM2S_DMACR` bit[7](GenlockSrc) = 1, and `S2MM_DMACR` bit[7](GenlockSrc) = 1) frame pointers (`*_frm_ptr_out` and `*_frm_ptr_in`) are routed internally without having it connected outside the core.

[Figure 3-2](#) illustrates simple timing of Genlock operation. In this example `MM2S_FRMSTORE = 3`, `S2MM_FRMSTORE = 3`, `C_USE_FSYNC = 1`, the frame delay for S2MM has been set to 1. Also, MM2S has been configured as the Genlock Master (`C_MM2S_GENLOCK_MODE = 0`) and S2MM channel has been configured as the Genlock Slave (`C_S2MM_GENLOCK_MODE = 1`). The MM2S channel frame rate is faster than that of S2MM so the S2MM Slave skips frames automatically. As one can see in [Figure 3-2](#), in the time the MM2S channel cycles through frame 0, 1, 2 and back to 0, the S2MM channel has only cycled through two frame.

Due to the slow frame rate of S2MM compared to MM2S, the S2MM channel processes frame 2 then frame 0 then frame 2 again, skipping frame 1.

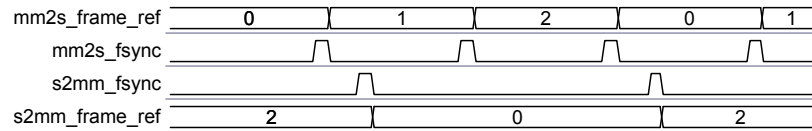

Figure 3-2: Example Genlock Timing

The Genlock mechanism that the AXI VDMA implements is based around the internal Start Address registers. The number of Start Address registers can be configured to be between 1 and 32. MM2S_FRMSTORE and S2MM_FRMSTORE specify this value for the associated channel with the C_NUM_FSTORES parameter specifying the maximum value. If large numbers of Frame Stores are not required, then specifying smaller values of C_NUM_FSTORE saves FPGA resources. The Genlock Master uses the index of the Start Address register to specify which Start Address register the Genlock Slave should use. This Start Address Register index is encoded as a Grey code value and appears on mm2s_frm_ptr_out and s2mm_frm_ptr_out for the MM2S and S2MM channels respectively.

The Grey Code that is used depends upon the number of Frame Stores that was specified. Table 3-2, Table 3-3, and Table 3-4 list the Grey Codes that are used for each of the 32 possible Frame Store sizes. The Grey Code cycles through all of the codes on the first line first and then cycles through all of the codes on the second line before repeating the first line. Number of grey codes is double the number of frame stores to allow for non-power-of-two frame store values to be cycled through and still maintain grey code coherency with minimal FPGA resources required.



IMPORTANT: AXI VDMA does not support intra-frame mode. That is, Genlock synchronization cannot be provided for writing and reading the same frame with a predetermined delay between write and read operations.

Table 3-2: Genlock Grey Code

FRMSTORE	Grey Code																
1	0																
2	0	1															
3	1	3	2														
4	0	1	3	2													
5	2	6	7	5	4												
6	3	2	6	7	5	4											
7	1	3	2	6	7	5	4										
8	0	1	3	2	6	7	5	4									
9	4	12	13	15	14	10	11	9	8								
10	5	4	12	13	15	14	10	11	9	8							
11	7	5	4	12	13	15	14	10	11	9	8						
12	6	7	5	4	12	13	15	14	10	11	9	8					
13	2	6	7	5	4	12	13	15	14	10	11	9	8				
14	3	2	6	7	5	4	12	13	15	14	10	11	9	8			
15	1	3	2	6	7	5	4	12	13	15	14	10	11	9	8		
16	0	1	3	2	6	7	5	4	12	13	15	14	10	11	9	8	

Table 3-3: Gen-Lock Grey Codes (Frame Store 17 to 32)

FrmStore (down) Frame number (right)	Grey Code															
	0	1	2	3	4	5	6	7	8	9	10	11	12	13	14	15
17	8 48	24 49	25 51	27 50	26 54	30 55	31 53	29 52	28 60	20 61	21 63	23 62	22 58	18 59	19 57	17 56
18	9 48	8 49	24 51	25 50	27 54	26 55	30 53	31 52	29 60	28 61	20 63	21 62	23 58	22 59	18 57	19 56
19	11 48	9 49	8 51	24 50	25 54	27 55	26 53	30 52	31 60	29 61	28 63	20 62	21 58	23 59	22 57	18 56
20	10 48	11 49	9 51	8 50	24 54	25 55	27 53	26 52	30 60	31 61	29 63	28 62	20 58	21 59	23 57	22 56
21	14 48	10 49	11 51	9 50	8 54	24 55	25 53	27 52	26 60	30 61	31 63	29 62	28 58	20 59	21 57	23 56
22	15 48	14 49	10 51	11 50	9 54	8 55	24 53	25 52	27 60	26 61	30 63	31 62	29 58	28 59	20 57	21 56
23	13 48	15 49	14 51	10 50	11 54	9 55	8 53	24 52	25 60	27 61	26 63	30 62	31 58	29 59	28 57	20 56
24	12 48	13 49	15 51	14 50	10 54	11 55	9 53	8 52	24 60	25 61	27 63	26 62	30 58	31 59	29 57	28 56
25	4 48	12 49	13 51	15 50	14 54	10 55	11 53	9 52	8 60	24 61	25 63	27 62	26 58	30 59	31 57	29 56
26	5 48	4 49	12 51	13 50	15 54	14 55	10 53	11 52	9 60	8 61	24 63	25 62	27 58	26 59	30 57	31 56
27	7 48	5 49	4 51	12 50	13 54	15 55	14 53	10 52	11 60	9 61	8 63	24 62	25 58	27 59	26 57	30 56
28	6 48	7 49	5 51	4 50	12 54	13 55	15 53	14 52	10 60	11 61	9 63	8 62	24 58	25 59	27 57	26 56
29	2 48	6 49	7 51	5 50	4 54	12 55	13 53	15 52	14 60	10 61	11 63	9 62	8 58	24 59	25 57	27 56
30	3 48	2 49	6 51	7 50	5 54	4 55	12 53	13 52	15 60	14 61	10 63	11 62	9 58	8 59	24 57	25 56
31	1 48	3 49	2 51	6 50	7 54	5 55	4 53	12 52	13 60	15 61	14 63	10 62	11 58	9 59	8 57	24 56
32	0 48	1 49	3 51	2 50	6 54	7 55	5 53	4 52	12 60	13 61	15 63	14 62	10 58	11 59	9 57	8 56

Table 3-4: Gen-Lock Grey Codes (Frame Store 17 to 32)

FrmStore (down) Frame number (right)	Grey Code															
	16	17	18	19	20	21	22	23	24	25	26	27	28	29	30	31
17	16 40															
18	17 40	16 41														
19	19 40	17 41	16 43													
20	18 40	19 41	17 43	16 42												
21	22 40	18 41	19 43	17 42	16 46											
22	23 40	22 41	18 43	19 42	17 46	16 47										
23	21 40	23 41	22 43	18 42	19 46	17 47	16 45									
24	20 40	21 41	23 43	22 42	18 46	19 47	17 45	16 44								
25	28 40	20 41	21 43	23 42	22 46	18 47	19 45	17 44	16 36							
26	29 40	28 41	20 43	21 42	23 46	22 47	18 45	19 44	17 36	16 37						
27	31 40	29 41	28 43	20 42	21 46	23 47	22 45	18 44	19 36	17 37	16 39					
28	30 40	31 41	29 43	28 42	20 46	21 47	23 45	22 44	18 36	19 37	17 39	16 38				
29	26 40	30 41	31 43	29 42	28 46	20 47	21 45	23 44	22 36	18 37	19 39	17 38	16 34			
30	27 40	26 41	30 43	31 42	29 46	28 47	20 45	21 44	23 36	22 37	18 39	19 39	17 34	16 35		
31	25 40	27 41	26 43	30 42	31 46	29 47	28 45	20 44	21 36	23 37	22 39	18 36	19 34	17 35	16 33	
32	24 40	25 41	27 43	26 42	30 46	31 47	29 45	28 44	20 36	21 37	23 39	22 38	18 34	19 35	17 33	16 32

The Grey codes received by the Genlock slave are then converted to a frame reference to tell the Genlock slave which frame to work on. The slave modifies the Genlock frame reference received by the frame delay such that the Genlock slaves remain a Frame Delay behind the Genlock Master. Table 3-5 illustrates an example conversion from Genlock Grey Code to Frame Reference used by the Genlock Slave.

Table 3-5: Example Grey Code Conversion for NUMFSTORE = 5

Grey To Frame Conversion	Grey Code Progressions for NUMFSTORE = 5									
Grey Code	2	6	7	5	4	12	13	15	14	10
Decoded Frame Reference	0	1	2	3	4	0	1	2	3	4

Additional Design Information

Scatter Gather Descriptor

When the AXI VDMA is configured for Scatter Gather Mode (C_INCLUDE_SG = 1), the Scatter Gather engine is used to pull in video transfer control information. This is accomplished by defining a linked list of transfer control information, referred to as a descriptor chain in system memory. A descriptor chain is required for each channel. The descriptor chain should be made up of MM2S_FRMSTORE and S2MM_FRMSTORE descriptors, respectively, where each descriptor is made up of seven 32-bit words. Each descriptor describes a video frame worth of transfers. The following describes the descriptor fields.

IMPORTANT: Descriptors must be aligned on eight 32-bit word alignment. Example valid offsets are 0x00, 0x20, 0x40, 0x60, and so on.

Table 3-6: Descriptor Fields

Address Space Offset ^a	Name	Description
00h	NXTDESC	Next Descriptor Pointer points to the first word of the next descriptor to fetch.
04h	RESERVED	N/A
08h	START_ADDRESS	Start Address points to the starting pixel to transfer for the given frame.
0Ch	RESERVED	N/A
10h	VSIZE	Vertical Size specifies the number of video lines to transfer for the given frame.
14h	HSIZE	Horizontal Size specifies the size in bytes of the horizontal line to transfer for a given frame.
18h	FRMDLY_STRIDE	Stride specifies the number of bytes between the first pixels of each horizontal line. Frame Delay specifies the number of frames a Genlock slave should be behind the Genlock Master.

a. Address Space Offset is relative to eight 32-bit word alignment in system memory, that is, 0x00, 0x20, 0x40 and so on.

NXTDESC (Next Descriptor Pointer)

This value provides the pointer to the next descriptor in the descriptor chain.

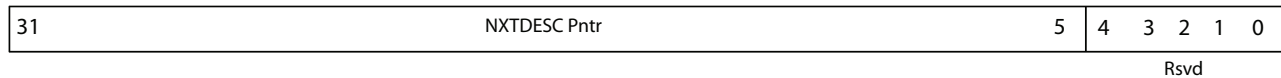

Figure 3-3: NXTDESC

Table 3-7: NXTDESC Details

Bits	Field Name	Description
31 downto 5	Next Descriptor Pointer	Indicates the lower order pointer pointing to the first word of the next descriptor. Note: Descriptors must be 8-word aligned, that is, 0x00, 0x20, 0x40, and so on. Any other alignment has undefined results.
4 downto 0	Reserved	These bits are reserved and should be set to zero.

START_ADDRESS (Start Address)

This value provides the pointer to the buffer of data to transfer from system memory to stream.

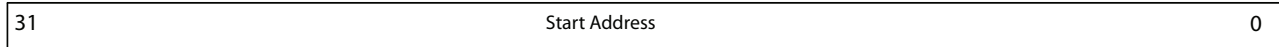

Figure 3-4: Start Address

Table 3-8: START_ADDRESS Details

Bits	Field Name	Description
31 downto 0	Start Address	Provides the starting pixel location of the data to transfer. For MM2S channel, data is read from system memory starting at this address. For S2MM channel, data is written to system memory starting at this address. Note: If the Data Realignment Engine is included (C_INCLUDE_MM2S_DRE = 1 or C_INCLUDE_S2MM_DRE = 1) for the respective channel, the Start Address can be at any byte offset. If the Data Realignment Engine is not included (C_INCLUDE_MM2S_DRE = 0 or C_INCLUDE_S2MM_DRE = 0) for the respective channel, the Start Address must be stream data width aligned.

VSIZE (Vertical Size)

This value provides vertical size (or number of lines) to transfer.

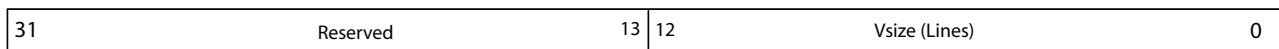

Figure 3-5: VSIZE

Table 3-9: VSIZE Details

Bits	Field Name	Description
31 downto 13	Reserved	This bit is reserved and should be written as zero.
12 downto 0	VSize	Vertical size in lines of the video data to transfer. On the MM2S stream interface there are vsize number of packets that are hsize bytes long transmitted for each frame. On the S2MM stream interface, the vsize number of packets that are hsize bytes long are expected to be received for each frame. Note: A value of zero on Vsize causes a MM2S_DMAIntErr or S2MM_DMAIntErr for the associated channel to be logged and the channel with the detected error is shut down.

HSIZE (Horizontal Size)

This value provides horizontal size in bytes of the video line to transfer.

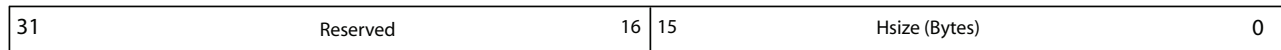

Figure 3-6: HSIZE

Table 3-10: HSIZE Details

Bits	Field Name	Description
31 downto 16	Reserved	These bits are reserved and should be set to zero.
15 downto 0	HSize	<p>Horizontal size in bytes of the video data to transfer. On the MM2S stream interface there are vsize number of packets that are hsize bytes long transmitted for each frame. On the S2MM stream interface, vsize number of packets that are hsize bytes long are expected to be received for each frame.</p> <p>Note: If more or less data are received on the S2MM stream interface, an underrun or overrun error occurs. The channel will not halt on line size errors.</p> <p>Note: A value of zero for Hsize causes a MM2S_DMAIntErr or S2MM_DMAIntErr for the associated channel to be logged and the channel with the detected error is shut down.</p>

FRMDLY_STRIDE (Frame Delay and Stride)

This value provides the Genlock Frame Delay and Stride for the video transfer.

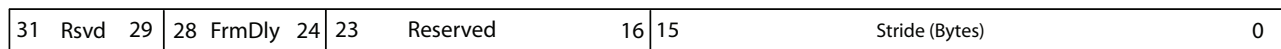

Figure 3-7: FRMDLY_STRIDE

Table 3-11: FRMDLY_STRIDE Details

Bits	Field Name	Description
31 downto 29	Reserved	These bits are reserved and should be set to zero.
28 downto 24	FrmDly	Frame Delay is the number of frame stores that the slave should be behind the locked master. This field is only used if the channel is enabled for Genlock Slave Operations (C_MM2S_GENLOCK_MODE = 1 or C_S2MM_GENLOCK_MODE=1) for the respective channel. Note: Frame Delay must be less than or equal to MM2S_FRMSTORE or S2MM_FRMSTORE for the respective channel or undefined results occur.
23 downto 16	Reserved	These bits are reserved and should be set to zero.
15 downto 0	Stride	Number of bytes between first pixels of each video line. Note: Stride values less than HSize results in corrupt data.

Line Buffers

An optional line buffer can be utilized to prevent memory controller throttling from causing inner packet throttling on the stream interface. The user can configure line buffer depth (with C_MM2S_LINEBUFFER_DEPTH and C_S2MM_LINEBUFFER_DEPTH) to provide the necessary buffering for a specific video application. Line buffer is an asynchronous buffer and must be enabled if AXI4 Memory map and AXI4-Stream clocks are different.

Line buffer status is provided for video IP use. The signals mm2s_linebuffer_empty and mm2s_linebuffer_almost_empty are provided for the MM2S channel and s2mm_linebuffer_full and s2mm_linebuffer_almost_full are provided for the S2MM channel. Threshold parameters are provided to specify the assertion points for mm2s_linebuffer_almost_empty and s2mm_linebuffer_almost_full.

Example MM2S Timing

Figure 3-8 illustrates example timing on MM2S channel for C_USE_FSYNC = 1, Vertical Size = 5 lines, Horizontal Size = 16, bytes, and Stride = 32 bytes. The figure shows the m_axi_mm2s and m_axis_mm2s interfaces.

Dataflow: After the reception of mm2s_fsync, AXI VDMA asserts m_axi_mm2s_arvalid with the start address on m_axi_mm2s_araddr. The signal m_axi_mm2s_arvalid is asserted five times to fetch five (vsize) lines of a frame. Read data from the mm side is stored in the line buffer and delivered on the streaming side by asserting m_axis_mm2s_tvalid. The signal m_axis_mm2s_tlast is asserted at the end of each line.

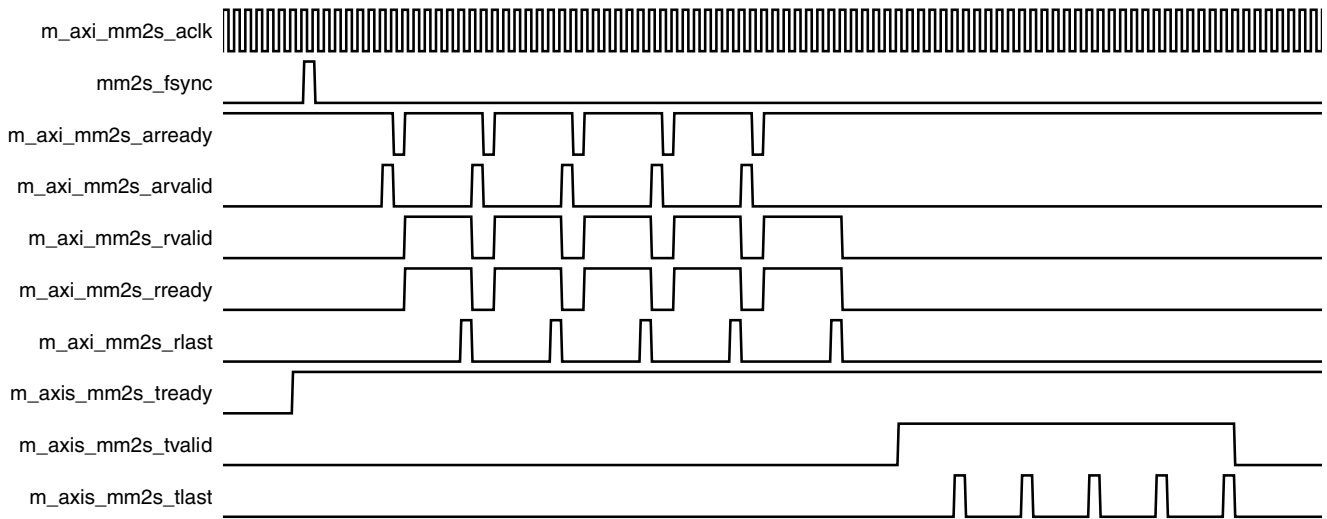

Figure 3-8: Example MM2S Interface Timing

Example S2MM Timing

Figure 3-9 illustrates example timing on S2MM channel for C_USE_FSYNC = 1, Vertical Size = 5 lines, Horizontal Size = 16, bytes, and Stride = 32 bytes. The figure shows the m_axi_s2mm and s_axis_s2mm interfaces.

Dataflow: After the reception of s2mm_fsync, AXI VDMA drives s2mm_fsync_out and s_axis_s2mm_tready to indicate its readiness to receive a frame on the streaming interface. Incoming streaming data is stored in the line buffer and driven onto the mm side by asserting m_axi_s2mm_awvalid and subsequently driving data on m_axi_s2mm_wdata along with m_axi_s2mm_wvalid.

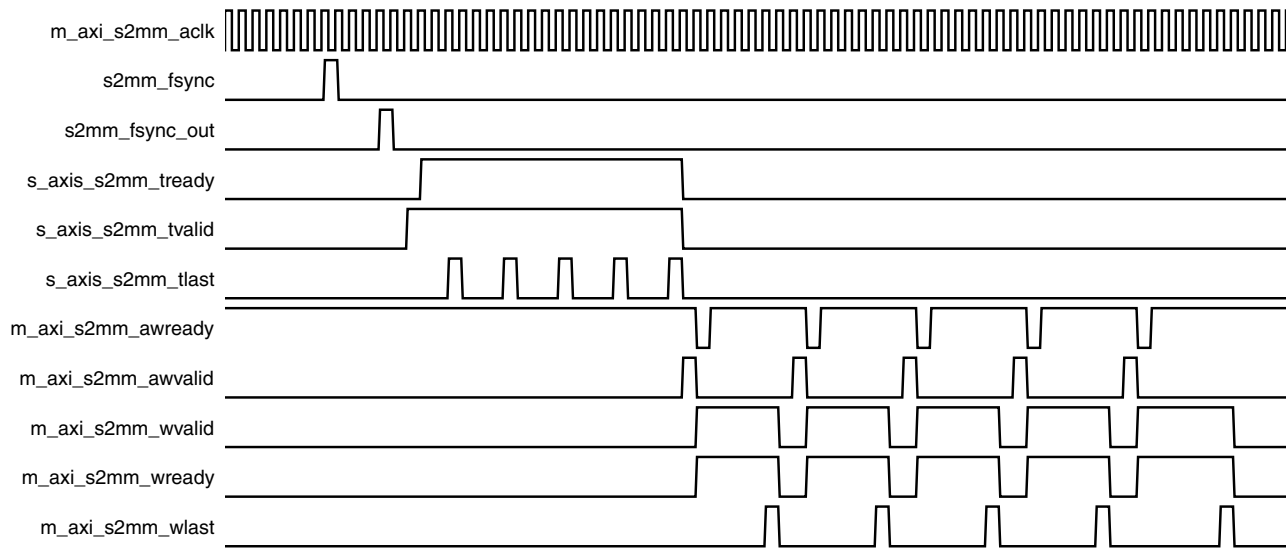

Figure 3-9: Example S2MM Interface Timing

Example Scatter Gather Timing

Figure 3-10 illustrates example timing for the Scatter Gather interface. The figure shows `m_axi_sg` interface timing with respect to `m_axi_mm2s` interface.

Dataflow: The SG engine starts when `TAILDESC POINTER` is written with a new value. `C_NUM_FSTORES` is programmed to 3. A chain of three descriptors are fetched. The signal `mm2s_fsync` is not sampled until AXI VDMA has completed fetching `C_NUM_FSTORES` of descriptors. On completion of descriptor fetching, AXI VDMA drives `mm2s_fsync_out` to signal a new frame start boundary. AXI VDMA then asserts `m_axi_mm2s_arvalid` with the start address on `m_axi_mm2s_araddr`. The signal `m_axi_mm2s_arvalid` is asserted five times to fetch five (`vsize`) lines of a frame. Read data from the mm side is stored in the line buffer and delivered on the streaming side by asserting `m_axis_mm2s_tvalid`. The signal `m_axis_mm2s_tlast` is asserted at the end of each line.

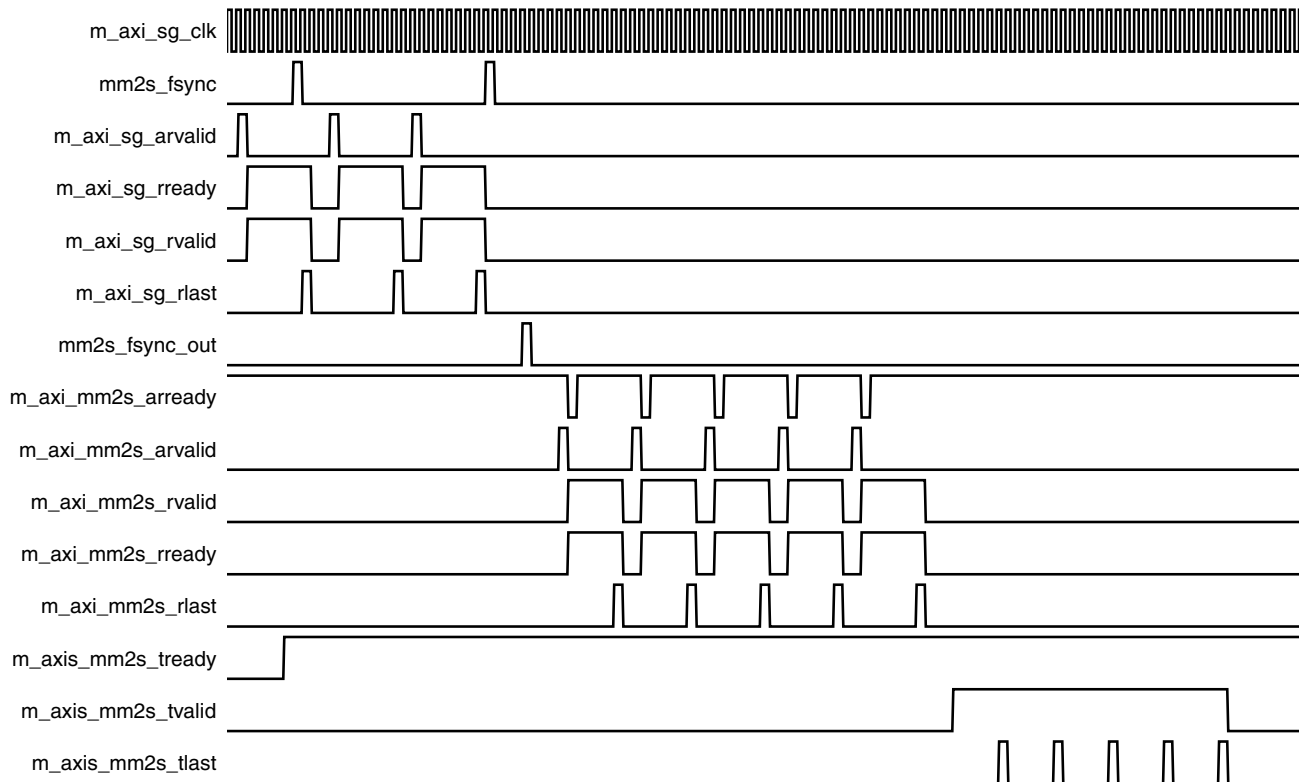

Figure 3-10: Example Scatter Gather Timing

AXI VDMA System Configuration

The AXI Interconnect interfacing to the AXI VDMA AXI4 Memory Map ports on MM2S and S2MM can be configured to improve system performance. Read and Write Data FIFOs can be turned on in the AXI Interconnect to allow read and/or write data to be buffered up.

Enabling the FIFOs along with limiting the number of outstanding read and write requests accepted by AXI Interconnect guarantees that all requested data to be transferred can be accepted by the AXI Interconnect preventing deadlock.

To enable these AXI Interconnect features, four non-HDL parameters are provided:

- C_INTERCONNECT_M_AXI_MM2S_READ_ISSUING
- C_INTERCONNECT_M_AXI_MM2S_READ_FIFO_DEPTH
- C_INTERCONNECT_M_AXI_S2MM_WRITE_ISSUING
- C_INTERCONNECT_M_AXI_S2MM_WRITE_FIFO_DEPTH

Setting these parameters correctly configures the AXI Interconnect interfaced to the Memory Map ports of the AXI VDMA. For example, if `C_MM2S_MAX_BURST_LENGTH` is set to 16 and `C_INTERCONNECT_M_AXI_MM2S_READ_ISSUING` is set to 4, then the product of these two values is $16 \times 4 = 64$. Therefore, the setting `C_INTERCONNECT_M_AXI_MM2S_READ_FIFO_DEPTH = 512` is sufficient to satisfy the requirements ($16 \times 4 = 64$ which is less than 512). Following is the formula presented for clarity:

$$*_MAX_BURST_LENGTH \times *_ISSUING < *_FIFO_DEPTH$$

Interrupt Controller

An interrupt output is provided for each channel (MM2S and S2MM). This output drives High when the interrupt frame count is met, if there is a delay interrupt, or an error if the associated interrupt is enabled.

Threshold Interrupt

Interrupt coalescing can be accomplished by setting the `DMACR.IRQFrameCount` field. With each frame completion event (that is, transmitted last line of frame or Received last line of frame when `C_USE_FSYNC = 0` or on `mm2s_fsync` or `s2mm_fsync` for when `C_USE_FSYNC = 1,2,3`) the frame count is decremented. When the count reaches zero, `FrmCnt_Irq` asserts and if `FrmCnt_IrqEn = 1`, then an interrupt is generated on the associated channels introut signal (that is, `mm2s_introut` or `s2mm_introut`). When a frame count interrupt is generated, the frame count is reloaded in the counter in preparation for the next frame count event.

The internal frame count value is presented to software in `DMASR.IRQFrameCntSts`. A `DMACR.IRQFrameCount` value of 0x01 (default) cause a single frame count interrupt event to immediately generate an interrupt out.

If the delay interrupt is enabled (`DMACR.IRQDelayCount` not equal to 0 and `DMACR.DlyIrq_En = 1`), then a delay interrupt event also reloads the internal frame count counter. Finally with each software write of the frame count value (`DMACR.IRQFrameCount`), the internal counter is reloaded.

Delay Interrupt

The delay interrupt is a mechanism by which software can receive an interrupt if there is a huge delay between `fsync` pulse assertion and start of packet (assertion of `tvalid`).

The delay count interrupt is enabled by setting the `DMACR.IRQDelay` value to a non-zero value. The delay counter begins counting either upon receipt of frame sync (`mm2s_fsync` or `s2mm_fsync`) for `C_USE_FSYNC = 1,2,3` or the completion of the transfer of `vsize` lines in free run mode for the respective channel. The delay counter resets with subsequent Start of Packet (`tvalid` assertion).

When a delay interrupt event occurs, the delay timer is reset to zero, generating a IRQDelayCount event. If the DMACR.DlyCnt_IrqEn = 1 for the respective channel, then an interrupt out is generated from AXI VDMA. The delay timer does not count until the CPU services the interrupt by clearing the DMASR.DlyCnt_Irq bit to 0. Figure 3-11 shows example timing for this situation.

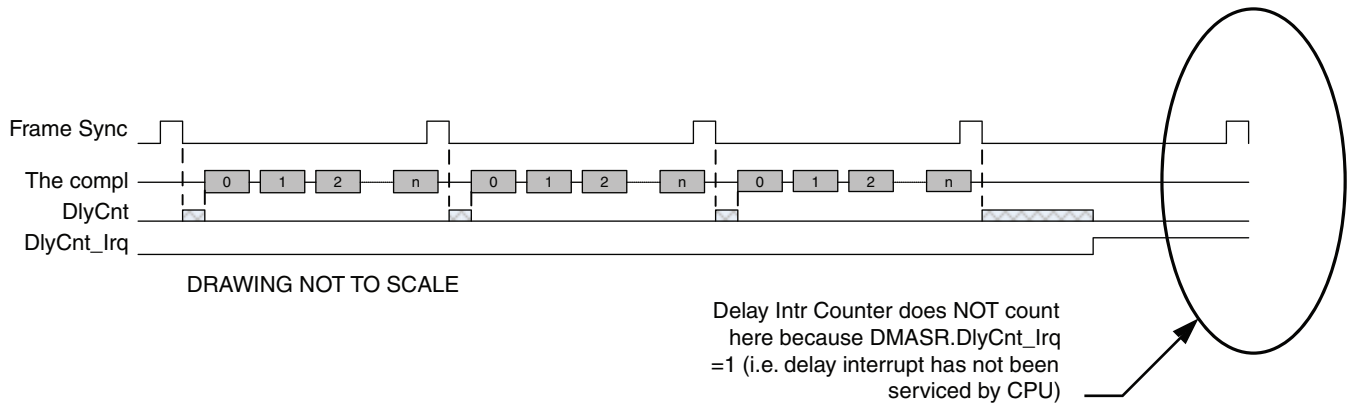

Figure 3-11: Example Delay Timer Timing

Note: Delay Interrupt is not enabled when TUSER(0) is used as Start of Frame.

Errors

Any detected error on the primary datapath (that is, DMAIntErr, DMASlvErr, and DMADecErr) results in the associated channel (MM2S or S2MM) to halt gracefully when C_FLUSH_ON_FSYNC=0. Any Scatter Gather Engine detected error (that is, SGSlvErr or SGDecErr) causes the entire AXI VDMA engine to halt gracefully.

When an error is detected, the errored channel DMACR.RS bit is set to 0. In accordance with AXI protocol all AXI transfers on memory map interfaces must complete; therefore, the AXI VDMA completes all pending transactions (transactions already posted and accepted on memory map interfaces) before setting the errored channel DMASR.Halted bit. When the DMASR.Halted bit is set to 1, then the AXI VDMA channel is truly halted.

Furthermore for DMA detected errors the associated channel FrmStore pointer (RdFrmStore or WrFrmStore) is updated with the frame reference of the errored frame. For SG detected errors the descriptor associated with the errored transfer is updated to the channel CURDESC pointer register. If multiple, simultaneous errors are detected, then only one of the detected error CURDESC is updated.

To resume operations, a reset must be issued, either soft or hard. If using soft reset, then for Scatter gather errors a reset must be issued to both channels. For primary DMA errors, the reset must be issued only to the channel that logged the error. Hard resets, reset the entire AXI VDMA engine.

Following is a list of possible errors:

DMAIntErr (C_INCLUDE_SG = 1/0)

DMA Internal Error flags an internal error in the AXI DataMover was detected. This can occur under two conditions.

This error can occur when a BTT = 0 is written to the primary AXI DataMover. For Scatter Gather Mode (C_INCLUDE_SG = 1) this happens if a descriptor is fetched with the VSIZE or HSIZE = 0. For Register Direct Mode (C_INCLUDE_SG = 0) this happens if the VSIZE and/or HSIZE register for the respective channel = 0 when the VSIZE register was written. This error also occurs when there is a frame size mismatch between programmed vsize and received(S2MM path)/transmitted(MM2S path) lines.

DMASlvErr (C_INCLUDE_SG = 1/0)

DMA Slave Error occurs when the slave to/from which data are transferred responds with a SLVERR on the memory map interface.

DMADecErr (C_INCLUDE_SG = 1/0)

DMA Decode Error occurs when the address request is targeted to an address that does not exist.

SGSlvErr (C_INCLUDE_SG = 1)

Scatter Gather Slave Error occurs when the slave from which descriptors are fetched responds with a SLVERR.

SGDecErr (C_INCLUDE_SG = 1)

Scatter Gather Decode Error occurs when the address request is targeted to an address that does not exist.

Table 3-12: MM2S Errors

Cause	MM2S Errors	Operating Mode	
		Free run(C_USE_FYNC = 0)	External fsync(C_USE_FSYNC=1) and Flush on fsync(C_FLUSH_ON_FSYNC=1)
VDMA configured for too many lines w.r.t. Streaming Slave	SOFEarlyErr (bit7 of offset 0x04h). R/WC in flush mode. RO in non-flush mode.	This error cannot happen in free-run mode.	Channel does not HALT. Channel goes out-of-sync until next fsync, asserts TVALID low and does not provide any data until next fsync.
VDMA configured for too few lines w.r.t. Streaming Slave	Expect video IP to detect error	This error cannot happen in MM2S channel.	This error cannot happen in MM2S channel.
VDMA configured for too many bytes per line w.r.t. Streaming Slave	Expect video IP to detect error	This error cannot happen in MM2S channel.	This error cannot happen in MM2S channel.
VDMA configured for too few bytes per line w.r.t. Streaming Slave	Expect video IP to detect error	This error cannot happen in MM2S channel.	This error cannot happen in MM2S channel.

Table 3-13: S2MM Errors

Cause	S2MM Errors	Operating Mode	
		Free run(C_USE_FYNC = 0)	External fsync(C_USE_FSYNC=1) and Flush on fsync(C_FLUSH_ON_FSYNC=1)
VDMA configured for too many lines w.r.t. Streaming Master	SOFEarlyErr (bit 7 of offset 0x34h). R/WC in flush mode. RO in non-flush mode.	This error cannot happen in free-run mode. VDMA waits infinitely for pending lines.	Channel does not HALT. Channel goes out-of-sync until next fsync, asserts TREADY high but does not transfer data till next fsync.
VDMA configured for too few lines w.r.t. Streaming Master	SOFLateErr (bit 11 of offset 0x34h). R/WC in flush mode. RO in non-flush mode.	This error cannot happen in free-run mode.	After receiving the VSIZE number of video lines, channel continues to assert TREADY high. If Streaming Master drives more data, it is dropped and this error bit is set.

Table 3-13: S2MM Errors (Cont'd)

Cause	S2MM Errors	Operating Mode	
VDMA configured for too many bytes per line w.r.t. Streaming Master	EOLEarlyErr (bit 8 of offset 0x34h). R/WC in all modes	Channel does not HALT.	Channel does not HALT.
VDMA configured for too few bytes per line w.r.t. Streaming Master	EOLLateErr (bit 15 of offset 0x34h). R/WC in all modes	Channel does not HALT. Extra bytes received in the line are dropped.	Channel does not HALT. Extra bytes received in the line are dropped.



RECOMMENDED: It is recommended to have `C_MM2S_SOF_ENABLE = 1` `C_S2MM_SOF_ENABLE = 1` and `C_FLUSH_ON_FSYNC = 1` where all VDMA is continued to work irrespective of error conditions mentioned in the preceding tables. Setting `C_S2MM_SOF_ENABLE = 1` also provides access to `fsync` cross-bar through which different `fsync` sources can be selected.

Triple Frame Buffer Example

Triple buffers or drop/add frame synchronizers are a common use for the AXI VDMA. Triple buffers can be used to pass image frames between two distinct clock domains without shear. Shear occurs when a frame is read from memory but that frame is made up of two different write frames. When the read and write clocks are asynchronous, the read and write memory pointers will cross each other at some point in time resulting in shear. To avoid shear, read and write pointers are not allowed to cross each other which results in frames being repeated or skipped. One or more AXI VDMA's can be used to implement this feature.

Generic triple buffers get the name by using three distinct frame stores to write and read data into and from memory. At no time is the read or write frame location allowed to overlap the other (for example, one cannot read and write from frame store #1 at the same time). This removes the possibility of shear in the read image that is possible in a double buffer scheme. Generic triple buffers use the following rules to ensure that reads and writes do not occur in the same frame store.

- Because there are three distinct frame stores and two possible operations (read and write), one frame store is always available and is denoted as the extra frame.
- When the write frame finishes, its next frame location is the extra frame location. The extra frame location becomes the write frame location. In essence, the locations swap between write and extra when the write completes. If the swap occurs twice prior to read frame completion, a skip (drop) frame occurs.
- When the read frame finishes, its next frame location is the newer (more recently written) of the extra frame or read frame. If the read frame is newer than the extra frame, a repeat (add) frame occurs.

The AXI VDMA mimics triple buffer capabilities by using Genlock synchronization. See [Genlock Synchronization](#). Genlock mode is different than the generic triple buffer. In a generic triple buffer, the write frame must know the extra frame location(s) and read frame location. Genlock mode removes this restriction by implementing an N buffer with N distinct frame stores. N is an integer value greater than the maximum ratio of (readClock/writeClock) or (writeClock/readClock). For example, reading at a clock rate of 74.25 MHz and writing at a clock rate of 148.5 MHz gives a maximum ratio of 2 and requires N=3 distinct frame stores (C_NUM_FSTORES = 3). Reading at a clock rate of 148.5 MHz and writing at a clock rate of 74.25 MHz gives the same maximum ratio of 2 with the same requirement of N=3. Generic triple buffers work by reading the last full frame written. Genlock mode enhances this capability by allowing the user to read an arbitrary number of frames behind the write frame by only modifying the FRMDLY register. This can be extremely useful in applications such as deinterlacing or motion adaptive noise reduction.

The following sequence details the steps required to implement a triple buffer with the AXI VDMA.

1. Configure the core with the following parameters.
 - a. Determine the value to use for Frame Stores. This integer value should be greater than the maximum ratio of read and write clocks. See [C_NUM_FSTORES](#) for details.
 - b. Enable
 - i. Asynchronous Clocks
 - ii. Flush on Frame Sync
 - iii. MM2S and S2MM Channel
 - iv. MM2S and S2MM Store and Forward
 - v. S2MM Frame Repeat on Error
 - c. Disable
 - i. Scatter Gather Engine.
 - d. Set S2MM Genlock Mode to Master.
 - e. Set External Fsync Options (Use Fsync) to 3. This puts Only S2MM channel in external Fsync mode and MM2S channel is in free-run mode.
 - f. Per user requirements
 - i. Set stream data widths to user data sizes.
 - ii. Set memory map data widths to match AXI Interconnect requirements. Suggest stream data width x 4.

- iii. Set maximum burst size. Use default settings from the GUI. This should work for most cases. (See the *AXI Reference Guide* ([UG761](#)) for more information on maximizing the AXI Interconnect performance.)
 - iv. Line Buffer Depth. (Suggest next power of two greater than maximum burst size x 6.)
 - v. Enable Start Of Frame on tuser(0). Select this option if the target peripherals implement the AXI4-Stream Video Protocol as described in the Video IP: AXI Feature Adoption section of the *AXI Reference Guide* ([UG761](#)). When this option is selected, `mm2s_fsync` and `s2mm_fsync` inputs are ignored. These signals can be tied to 0 or 1.
2. Configure the write registers as Genlock master.
 - a. Set `S2MM_DMACR` (30h) to 0x00000053. This enables run/stop, circular_park and SOF on tuser(0). See `S2MM_DMACR[6:5]` for selection of other synchronization sources.
 - b. Set `S2MM_Start_Address 1` (ACh) through `S2MM_Start_AddressN` to their required locations. These locations can be static (based on maximum frame size) or dynamic (based on actual frame size).
 - c. Set `S2MM_FRMDLY_STRIDE` (A8h) to the appropriate value. `FRMDLY` is 0 for the Genlock master. `STRIDE` is the number of bytes per line.
 - d. Set `S2MM_HSIZE` (A4h) to the number of bytes per line.
 - e. Set `S2MM_VSIZE` (A0h) to the number of lines per frame. `VSIZE` must be set last and starts the `S2MM` VDMA transactions.
 3. Configure the read registers as Genlock slave.
 - a. Set `MM2S_DMACR` (00h) to 0x0000008B. This enables run/stop, Circular_Park, and GenlockEn.
 - b. Set `MM2S_Start_Address1` (5Ch) through `MM2S_Start_AddressN` to their required locations. These locations should match their `S2MM_Start_Address` counterparts.
 - c. Set `MM2S_FRMDLY_STRIDE` (58h) to the appropriate value. `FRMDLY` is 1 for the Genlock slave. `STRIDE` is the number of bytes per line.
 - d. Set `MM2S_HSIZE` (54h) to the number of bytes per line.
 - e. Set `MM2S_VSIZE` (50h) to the number of lines per frame. `VSIZE` must be set last and starts the `MM2S` VDMA transactions.

When changing frame sizes, the incoming frame size might not match the S2MM HSIZE and VSIZE registers and an error is noted on S2MM DMASR register DMAIntErr. The preceding example enables S2MM Frame Repeat on Error and the next frame is written to the same frame store location invalidating the bad frame. If the start addresses are based on maximum frame sizes, no changes are necessary to their registers. However, the S2MM HSIZE and VSIZE registers must be updated with the new frame size. VSIZE should be written last. After a full frame is written into memory, the MM2S HSIZE and VSIZE registers can be updated and are used with the new frame after Frame Sync occurs.

SECTION II: VIVADO DESIGN SUITE

Customizing and Generating the Core

Constraining the Core

Customizing and Generating the Core

This chapter includes information on using Xilinx tools to customize and generate the core using the Vivado™ IP catalog. For more information about the Vivado Design Suite, see the [Vivado Design Suite - 2012.4 User Guides web page](#).

Vivado IP Catalog GUI Options

To access the AXI VDMA, do the following:

1. Open a project by selecting **File > Open Project** or create a new project by selecting **File > New Project**.
2. Open **IP Catalog** and choose **AXI Infrastructure/Video & Image Processing** in the **View by Function** pane.
3. Double-click **AXI Video Direct Memory Access** to display the AXI VDMA GUI.

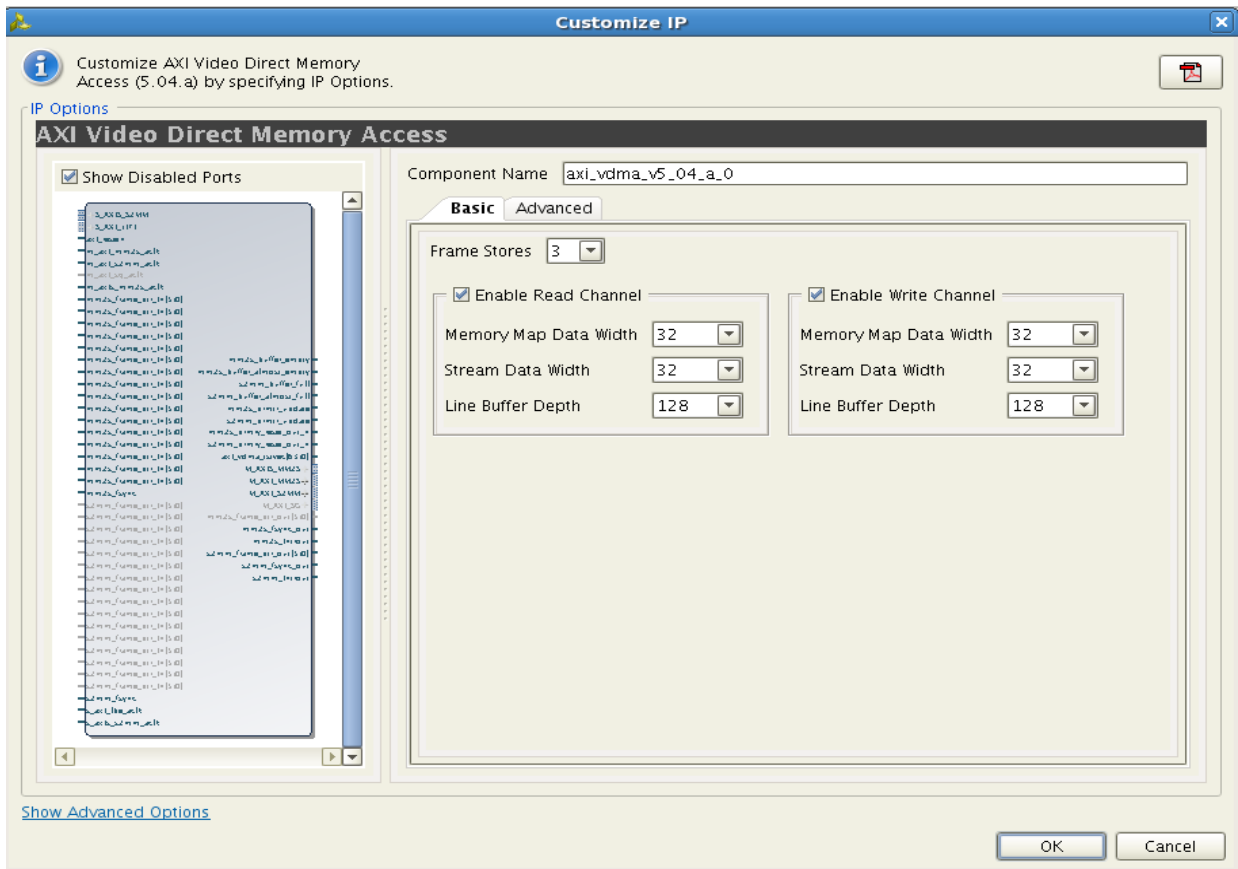

Figure 4-1: Page 1

Page 1 (Basic Options)

The following describes the fundamental options that affect both channels of the AXI VDMA core.

Frame Stores

This option enabled selection of the number of frame buffer storage locations to be processed by AXI VDMA.

Enable Read Channel

Checking this option enables MM2S Channel.

Memory Map Data Width

This option enables selection of desired AXI4 Memory Map data width for MM2S channel. Valid values are 32, 64, 128, 256, 512 and 1024.

Stream Data Width

This option enables selection of AXI4-Stream data width for MM2S channel. Valid values are multiples of 8 up to 1024 bits. This value must be less than or equal to Memory Map Data Width.

Line Buffer Depth

This option enables selection of line buffer depth for MM2S channel.

Enable Write Channel

Checking this option enables S2MM Channel

Memory Map Data Width

This option enables selection desired AXI4 Memory Map data width for S2MM channel. Valid values are 32, 64, 128, 256, 512 and 1024.

Stream Data Width

This option enables selection of AXI4-Stream data width for S2MM channel. Valid values are multiples of 8 up to 1024 bits. This value must be less than or equal to Memory Map Data Width.

Line Buffer Depth

This option enables selection of line buffer depth for S2MM channel.

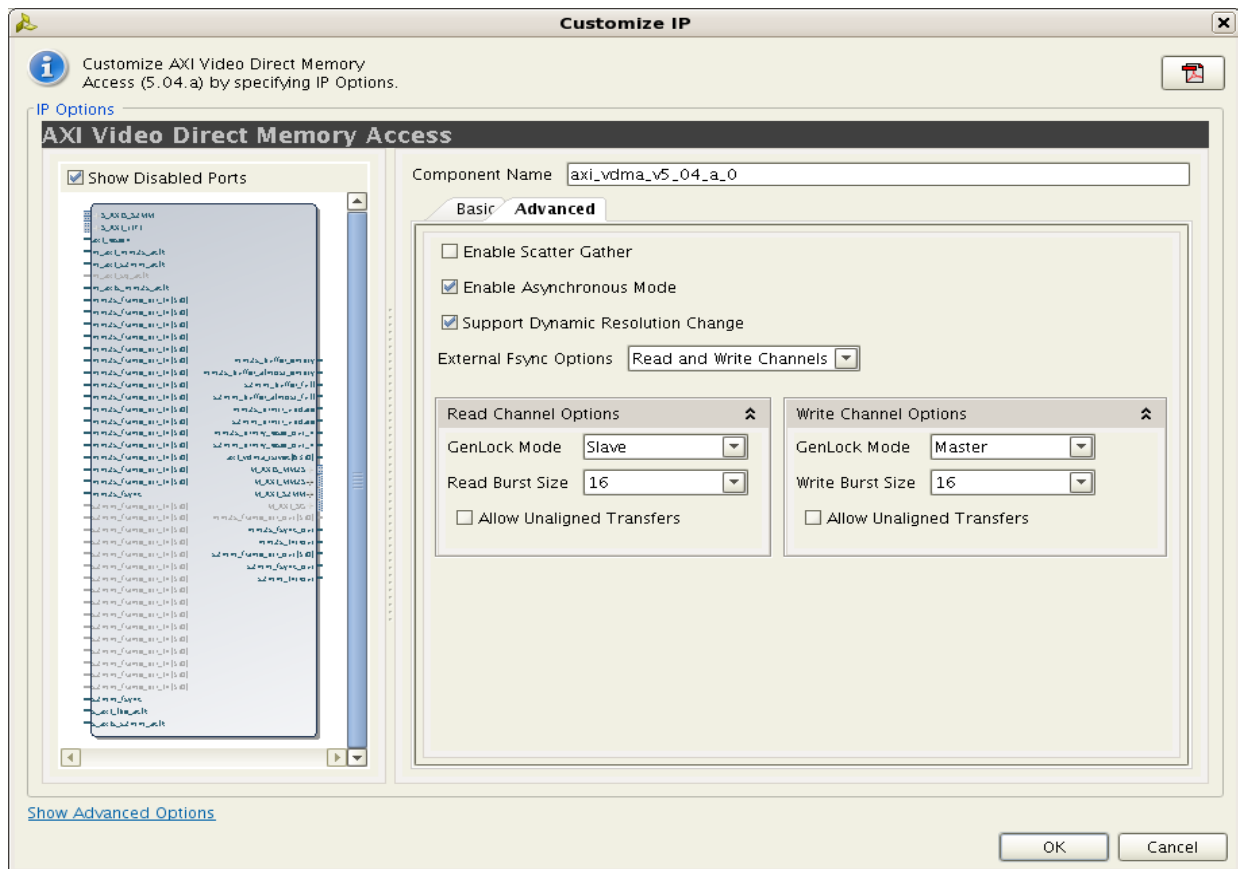

Figure 4-2: Page 2

Page 2 (Advanced Options)

The following describes advanced options that affect both channels of the AXI VDMA core

Enable Scatter Gather

Checking this option enables Scatter Gather Mode operation and includes the Scatter Gather Engine in AXI VDMA. Unchecking this option enables Register Direct Mode operation, excluding the Scatter Gather Engine from AXI VDMA. Disabling the Scatter Gather Engine causes all output ports for the Scatter Gather engine to be driven zeros and input ports are ignored.

Enable Asynchronous Mode

This setting allows operation of the MM2S interface `m_axi_mm2s_aclk`, S2MM interface `m_axi_s2mm_aclk`, AXI4-Lite control interface `s_axi_lite_aclk`, and the Scatter Gather Interface `m_axi_sg_aclk` to be asynchronous from each other. When Asynchronous Clocks are disabled, all clocks must be at the same frequency and from the same source.

External Fsync Options

This option is used to set the synchronization mode of the AXI VDMA.

None

Checking this option enables both MM2S (read) channel and S2MM(write) channel in free running mode.

Read and Write Channels

Checking this option enables both MM2S(read) channel and S2MM(write) channel to synchronize with external fsync.

Read Channel

Checking this option enables MM2S (read) channel to synchronize with external fsync and S2MM(write) channel is free running.

Write Channel

Checking this option enables S2MM (read) channel to synchronize with external fsync and MM2S (write) channel is free running.

Read Channel Options

It provides advanced options for MM2S path.

GenLock Mode

This option sets the Genlock Mode of the MM2S Channel. Selecting Master enables master mode and specifies that the MM2S channel operate as a Genlock Master. In Master mode, frames are not dropped or repeated. Selecting Slave enables slave mode and specifies that the MM2S channel operate as a Genlock Slave. In Slave mode, frames are automatically dropped or repeated based on the master and slave frame rates.

Selecting Dynamic Master enables Genlock Master to dynamically skip the frame buffers that Slave is operating on. Selecting Dynamic Slave enables Genlock Slave to work on the latest frame that the Master has operated on. Frame Delay is not valid in Dynamic Genlock modes. See C_MM2S_GENLOCK_MODE in Parameter Descriptions for more details.

Read Burst Size

This option specifies the maximum size of the burst cycles on the AXI MM2S Memory Map Read interface. For example, if the burst length is set to 16, the maximum burst on the memory map interface is 16 data beats.

Allow Unaligned Transfers

Enables or disables the MM2S Data Realignment Engine. When checked, the data realignment engine is enabled and allows data realignment to the byte (8 bits) level on the MM2S Memory Map datapath.

When unchecked, the Start Address must be aligned to multiples of C_M_AXI_MM2S_DATA_WIDTH bytes. Also Horizontal Size and Stride must be specified in even multiples of C_M_AXI_MM2S_DATA_WIDTH bytes. For example, if C_M_AXI_MM2S_DATA_WIDTH = 32, data is aligned if the Start Address at word offsets (32-bit offset), that is, 0x0, 0x4, 0x8, 0xC, and so on., Horizontal Size is 0x4, 0x8, 0xC and so on. Stride is 0x4, 0x8, 0xC, and so on. If C_M_AXI_MM2S_DATA_WIDTH = 64, data is aligned if the Start Address is at double-word offsets (64-bit offsets), that is, 0x0, 0x8, 0x10, 0x18, and so on, and Horizontal Size, and Stride are at 0x4, 0x8, 0xC, and so on.



IMPORTANT: *If Allow Unaligned Transfers is unchecked, unaligned start addresses, hsizes, or strides, are not supported. Having an unaligned Start Address, HSize, and/or Stride results in undefined behavior.*

Note: Further the Data Realignment Engine only supports AXI4-Stream data width setting of 64-bits and less.

Write Channel Options

It provides advanced options for S2MM path.

Genlock Mode

This option sets the Genlock Mode of the S2MM Channel. Selecting Master enables master mode and specifies that the S2MM channel operate as a Genlock Master. In Master mode, frames are not dropped or repeated. Selecting Slave enables slave mode and specifies that the S2MM channel operate as a Genlock Slave. In Slave mode, frames are automatically dropped or repeated based on the master and slave frame rates.

Selecting Dynamic Master enables Genlock Master to dynamically skip the frame buffers that Slave is operating on. Selecting Dynamic Slave enables Genlock Slave to work on the latest frame that the Master has operated on. Frame Delay is not valid in Dynamic Genlock modes. See C_S2MM_GENLOCK_MODE in Parameter Descriptions for more details.

Write Burst Size

This setting specifies the maximum size of the burst cycles on the AXI S2MM Memory Map Write interface. For example, if the burst length is set to 16, the maximum burst on the memory map interface is 16 data beats.

Allow Unaligned Transfers

Enables or disables the S2MM Data Realignment Engine. When checked, the data realignment engine is enabled and allows data realignment to the byte (8 bits) level on the S2MM Memory Map datapath. When unchecked, the Start Address must be aligned to multiples of C_M_AXI_S2MM_DATA_WIDTH bytes. Also Horizontal Size and Stride must be specified in even multiples of C_M_AXI_S2MM_DATA_WIDTH bytes.



IMPORTANT: *If Allow Unaligned Transfers is unchecked, unaligned start addresses, hsizes, or strides, are not supported. Having an unaligned Start Address, HSize, and/or Stride results in undefined behavior.*

Note: Further, the Data Realignment Engine only supports AXI4-Stream data width setting of 64-bits and less.

For the RTL parameters which are hidden in the IP Catalog GUI, following are the example commands to get or set the value of a hidden RTL parameter.

```
get_property -name CONFIG.c_include_mm2s_sf -object [get_ips axi_vdma_v5_xy_a_0] 0

set_property -name CONFIG.c_include_mm2s_sf -value {1} -objects [get_ips
axi_vdma_v5_xy_a_0] 1

get_property -name CONFIG.c_include_mm2s_sf -object [get_ips axi_vdma_v5_xy_a_0] 1
```

Output Generation

The output hierarchy when the core is generated from IP catalog is shown below:

The component name of the IP generated is axi_vdma.

- x - major version
- yz - minor version

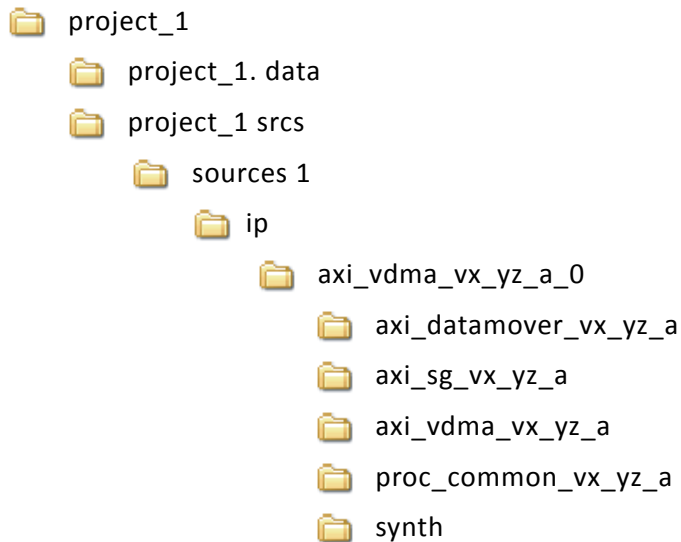

The RTL files of axi_vdma are delivered under `/ip/axi_vdma_x_yz_a/hdl/src/vhdl`. The `sim` and `synth` folders contain the wrappers for simulation and synthesis respectively. The tool also delivers the instantiation template file `.veo/.vho`.

Constraining the Core

This chapter contains information about constraining the core when using the Vivado™ Design Suite.

In synchronous mode, `C_PRMRY_IS_ACLK_ASYNC = 0`, all clocks run at the same frequency and are derived from the same source. There are no multicycle or false paths in this design. All logic between flop-to-flop should meet timing within one clock period.

In asynchronous mode, `C_PRMRY_IS_ACLK_ASYNC = 1`, all clocks are treated asynchronously to each other and the core will write out appropriate clock domain crossing constraints.

SECTION III: ISE DESIGN SUITE

Customizing and Generating the Core

Constraining the Core

Detailed Example Design

Customizing and Generating the Core

This chapter includes information about using Xilinx tools to customize and generate the core in the ISE® Design Suite.

Generating the Core Using CORE Generator Tool

The AXI VDMA can be found in **AXI Infrastructure/Video & Image Processing** in the CORE Generator™ tool graphical user interface (GUI) **View by Function** pane.

To access the AXI VDMA, do the following:

1. Open a project by selecting **File > Open Project** or create a new project by selecting **File > New Project**.
2. With an open project, choose **AXI Infrastructure/Video & Image Processing** in the **View by Function** pane.
3. Double-click **AXI Video Direct Memory Access** to display the AXI VDMA GUI.

CORE Generator Tool Parameter Screen

The AXI VDMA GUI contains one screen ([Figure 6-1](#)) that provides information about the core, allows for configuration of the core, and provides the ability to generate the core.

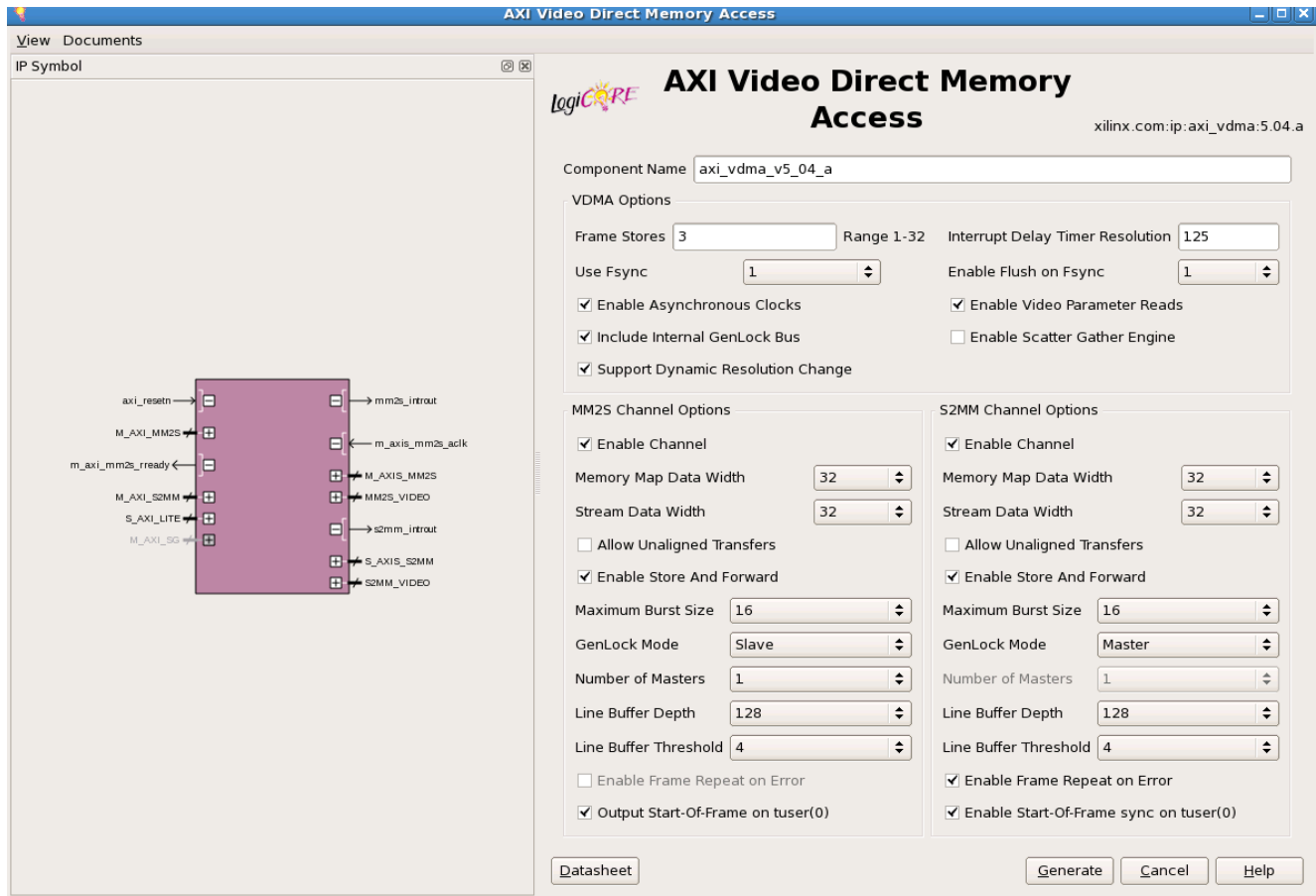

Figure 6-1: AXI VDMA GUI

Component Name

The base name of the output files generated for the core. Names must begin with a letter and can be composed of any of the following characters: a to z, 0 to 9, and "_".

VDMA Options

The following subsections describe options that affect both channels of the AXI VDMA core.

Frame Stores

Frame Stores indicates the number of frame buffer storage locations to be processed by the AXI VDMA. In Register Direct Mode (C_INCLUDE_SG = 0) this value determines the number of valid Start Addresses per channel that need to be initialized. For Scatter Gather mode (C_INCLUDE_SG = 1) this parameter defines the number of Scatter Gather descriptors per channel in the descriptor chain required to initialize the AXI VDMA. Valid values are 1 to 32.

Use Frame Sync

This option is used to set the synchronization mode of the AXI VDMA. Uncheck to select Free Run Mode and check to select Frame Sync Mode. See [C_USE_FSYNC](#) in [Parameter Descriptions](#) for more details.

Enable Scatter Gather Engine

Checking this option enables Scatter Gather Mode operation and includes the Scatter Gather Engine in AXI VDMA. Unchecking this option enables Register Direct Mode operation of AXI VDMA. Disabling the Scatter Gather Engine causes all output ports for the Scatter Gather engine to be driven zeros and input ports are ignored.

Enable Video Parameter Reads

Checking this option enables the reading of the video transfer parameters (vsize, hsize, stride, and frame delay) and start addresses using the `s_axi_lite` control interface. For applications where reading of the video transfer parameters is not needed then unchecking this option disables reading of video transfer parameters which saves FPGA resources.

Interrupt Delay Timer Resolution

This integer value sets the resolution of the Interrupt Delay Counter. Values specify the number of clock cycles between each tick of the delay counter. If Scatter Gather Engine is enabled, clock cycles are based on the `m_axi_sg_aclk` clock input. If Scatter Gather Engine is disabled, clock cycles are based on `s_axi_lite_aclk` clock cycles.

Enable Asynchronous Clocks

This setting allows operation of the MM2S interface `m_axi_mm2s_aclk`, S2MM interface `m_axi_s2mm_aclk`, AXI4-Lite control interface `s_axi_lite_aclk`, and the Scatter Gather Interface `m_axi_sg_aclk` to be asynchronous from each other. When Asynchronous Clocks are disabled, all clocks must be at the same frequency and from the same source.

Enable Flush on Frame Sync

This setting enables the AXI VDMA to reset internal states and flush transfer data on frame sync. This allows VDMA to restart transfers at the beginning of a new frame after DMA Internal error detection as opposed to halting. This feature is only enabled when the channel uses external frame sync. There are options to enable flush on frame sync mode for MM2S and S2MM channels independently.

Include Internal Genlock Bus

This setting allows internal routing of MM2S and S2MM Genlock buses without having connecting them outside the core.

MM2S Channel Options

The following subsections describe options that affect only the MM2S Channel of the AXI VDMA core.

Enable Channel

This option enables or disables the MM2S channel.

Memory Map Data Width

Data width in bits of the AXI MM2S Memory Map Read data bus. Valid values are 32, 64, 128, 512 and 1024.

Stream Data Width

Data width in bits of the AXI MM2S AXI4-Stream data bus. Valid values are multiples of 8 up to 1024 bits. This value must be less than or equal to Memory Map Data Width.

Allow Unaligned Transfers

Enables or disables the MM2S Data Realignment Engine. When checked, the data realignment engine is enabled and allows data realignment to the byte (8 bits) level on the MM2S Memory Map datapath.

When unchecked, that is, for the case where unaligned transfers are *not* allowed, the Start Address must be aligned to multiples of C_M_AXI_MM2S_DATA_WIDTH bytes. Also Horizontal Size and Stride must be specified in even multiples of C_M_AXI_MM2S_DATA_WIDTH bytes.



IMPORTANT: *If Allow Unaligned Transfers is unchecked then unaligned start addresses, hsizes, or strides, are not supported. Having an unaligned Start Address, HSize, and/or Stride results in undefined behavior.*

Note: Further the Data Realignment Engine only supports AXI4-Stream data width setting of 64-bits and less.

Enable Store and Forward

This option enables or disables the Store and Forward buffer for the MM2S channel. When enabled, read requests on MM2S are only made if there is enough buffer space in the Store-and-Forward buffer to complete the burst.

Maximum Burst Size

This option specifies the maximum size of the burst cycles on the AXI MM2S Memory Map Read interface. For example, if the burst length is set to 16, the maximum burst on the memory map interface is 16 data beats.

Genlock Mode

This option sets the Genlock Mode of the MM2S Channel. Selecting **Master** enables master mode and specifies that the MM2S channel operate as a Genlock Master. In Master mode, frames are not dropped or repeated. Selecting **Slave** enables slave mode and specifies that the MM2S channel operate as a Genlock Slave. In Slave mode, frames are automatically dropped or repeated based on the master and slave frame rates.

Selecting **Dynamic Master** enables Genlock Master to dynamically skip the frame buffers that Slave is operating on. Selecting **Dynamic Slave** enables Genlock Slave to work on the latest frame that the Master has operated on. Frame Delay is not valid in Dynamic Genlock modes. See [C_MM2S_GENLOCK_MODE](#) in [Parameter Descriptions](#) for more details.

Number of Masters

This setting specifies to the Genlock slave the total number of masters to synchronize operations to. This setting also specifies the vector width of the `mm2s_frm_ptr_in` port, where each master requires 6 bits on the `mm2s_frm_ptr_in` vector. Therefore, the width of the `mm2s_frm_ptr_in` port is $6 \times \text{Number of Masters}$. Valid values are 1 to 16.

Line Buffer Depth

This setting specifies the inclusion of an MM2S Line Buffer and also specifies the depth. A setting of zero excludes the line buffer from the MM2S Channel.

See [C_MM2S_LINEBUFFER_DEPTH](#) in [Parameter Descriptions](#) for more details.

Line Buffer Threshold

This specifies the almost full threshold value of the `MM2S_THRESHOLD` register at which the almost full flag asserts/deasserts. This value is ignored by AXI VDMA if the Line Buffer Depth is set to 0. See [C_MM2S_LINEBUFFER_THRESH](#) in [Parameter Descriptions](#) for more details.

Enable Frame Advancement on Error

This setting enables or disables the MM2S Channel frame advancement on error when the channel is selected and operating as a master and Flush on Frame Sync setting is enabled.

Enable Start Of Frame on tuser(0)

This setting enables SOF generation for MM2S channel. SOF pulse is driven on `m_axis_mm2s_tuser(0)` coincident with first pixel of first line for each frame. For additional information, see the Video IP: AXI Feature Adoption section of the UG761 *AXI Reference Guide*.

S2MM Channel Options

The following subsections describe options that affect only the S2MM Channel of the AXI VDMA core.

Enable Channel

This setting enables or disables the S2MM Channel.

Memory Map Data Width

Data width in bits of the AXI S2MM Memory Map Write data bus. Valid values are 32, 64, 128, 512 and 1024.

Stream Data Width

Data width in bits of the AXI S2MM AXI4-Stream Data bus. Valid values are multiples of 8 up to 1024 bits. This value must be less than or equal to Memory Map Data Width.

Allow Unaligned Transfers

Enables or disables the S2MM Data Realignment Engine. When checked, the data realignment engine is enabled and allows data realignment to the byte (8 bits) level on the S2MM Memory Map datapath.

When unchecked, that is, for the case where unaligned transfers are *not* allowed, the Start Address must be aligned to multiples of `C_M_AXI_S2MM_DATA_WIDTH` bytes. Also Horizontal Size and Stride must be specified in even multiples of `C_M_AXI_S2MM_DATA_WIDTH` bytes.



Note: Data Realignment Engine only supports AXI4-Stream data width setting of 64-bits and less.

Enable Store and Forward

This option is always set for S2MM channel. This parameter is redundant and will be removed in future versions.

Maximum Burst Size

This setting specifies the maximum size of the burst cycles on the AXI S2MM Memory Map Write interface. For example, if the burst length is set to 16, the maximum burst on the memory map interface is 16 data beats.

Genlock Mode

This option sets the Genlock Mode of the S2MM Channel. Selecting **Master** enables master mode and specifies that the S2MM channel operate as a Genlock Master. In Master mode, frames are not dropped or repeated. Selecting **Slave** enables slave mode and specifies that the S2MM channel operate as a Genlock Slave. In Slave mode, frames are automatically dropped or repeated based on the master and slave frame rates.

Selecting **Dynamic Master** enables Genlock Master to dynamically skip the frame buffers that Slave is operating on. Selecting **Dynamic Slave** enables Genlock Slave to work on the latest frame that the Master has operated on. Frame Delay is not valid in Dynamic Genlock modes. See [C_S2MM_GENLOCK_MODE](#) in [Parameter Descriptions](#) for more details.

Number of Masters

This setting specifies to the Genlock slave the total number of masters to synchronize operations to. This setting also specifies the vector width of the `s2mm_frm_ptr_in` port, where each master requires 5 bits on the `s2mm_frm_ptr_in` vector. Therefore the width of the `s2mm_frm_ptr_in` port is $5 \times \text{Number of Masters}$. Valid values are 1 to 16.

Line Buffer Depth

This specifies the inclusion of an S2MM Line Buffer and also specifies the depth. A setting of zero excludes the line buffer from the S2MM Channel.

See [C_S2MM_LINEBUFFER_DEPTH](#) in [Parameter Descriptions](#) for more details.

Line Buffer Threshold

This specifies the almost empty threshold value of the `S2MM_THRESHOLD` register at which the almost empty flag asserts/deasserts. This value is ignored by AXI VDMA if the Line Buffer Depth is set to 0. See [C_S2MM_LINEBUFFER_THRESH](#) in [Parameter Descriptions](#) for more details.

Enable Start Of Frame on tuser(0)

This setting along with FsyncSrcSelect = 10 enables SOF detection for S2MM channel on `s_axis_s2mm_tuser(0)`. SOF pulse received on `s_axis_s2mm_tuser(0)` coincident with the first pixel of the first line for each frame. For additional information, see the Video IP: AXI Feature Adoption section of the *AXI Reference Guide* ([UG761](#)).

Enable Frame Advancement on Error

This setting enables or disables the S2MM Channel frame advancement on error when the channel is selected and operating as a master and Flush on Frame Sync setting is enabled.

Generating the Core Using EDK

The AXI VDMA can be found in **IP Catalog - EDK_Install/DMA and Timer** in the Xilinx Platform Studio tool graphical user interface (GUI).

To access the AXI VDMA, do the following:

1. Invoke Xilinx Platform Studio and open a project by selecting **File > Open Project** or create a new project by selecting **File > New Project**.
2. With an open project, choose **EDK_Install/DMA and Timer**.
3. Double-click **AXI Video DMA** to display the AXI VDMA GUI.

For a new project:

1. Invoke Xilinx Platform Studio and create New Project using Base System Builder.
2. Select Interconnect Type (AXI System) and then select Board Name (based on 6/7 series FPGA)
3. After BSB is created, add AXI VDMA from IP catalog (**EDK_Install/DMA and Timer**) by double clicking **AXI Video DMA 5.04.a**. This opens up an EDK GUI which is described in the next section.

EDK pCore GUI

The AXI VDMA EDK GUI provides information about the core, allows for configuration of the core, and provides the ability to generate the core. The pCore is generated with each option set to the default value. [Figure 6-2](#) illustrates the EDK pCore GUI for the AXI VDMA. All of

the options in the EDK pCore GUI correspond to the same options in the CORE Generator tool GUI.

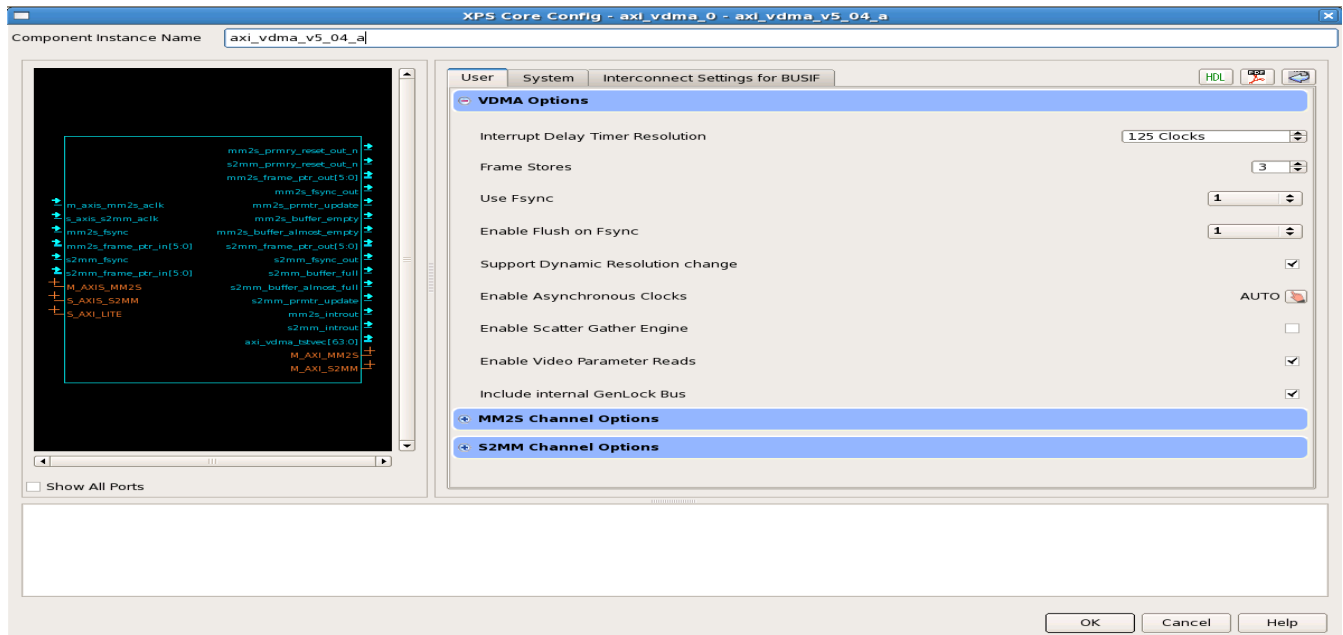

Figure 6-2: EDK pCore GUI

Output Generation

The output files generated from the CORE Generator tool are placed in the project directory. The file output list can include some or all of the following files.

Directory Hierarchy

<project directory>

Top-level project directory for the CORE Generator tool

<project directory>/<axi_vdma_component name>

Contains the AXI VDMA doc and source files.

<axi_vdma_component name>/doc

Contains the AXI VDMA solution PDF documentation.

<axi_vdma_component name>/hdl/src/vhdl

Contains the source files for AXI VDMA core.

File Details

<project directory>

This is the top-level file. It contains templates for instantiation the core and the xco file.

Table 6-1: Project Directory

Name	Description
<project_dir>	
<axi_vdma_component_name>.xco	Log file from CORE Generator tool describing which options were used to generate the AXI VDMA core. An XCO file is generated by the CORE Generator tool for each core that it creates in the current project directory. An XCO file can also be used as an input to the CORE Generator tool.
<axi_vdma_component_name>_flist.txt	A text file listing all of the output files produced when the customized AXI VDMA core was generated in the CORE Generator tool.
<axi_vdma_component_name>.vho	The HDL template for instantiating the AXI VDMA core.
<axi_vdma_component_name_synth>.vhd	The HDL synthesis wrapper file with the modified parameter configuration of AXI VDMA core.
<axi_vdma_component_name_sim>.vhd	The structural simulation model for the AXI VDMA core. It is used for functionally simulating the core.

[Back to Top](#)

<project directory>/<axi_vdma_component name>

This directory contains the doc and hdl folder.

<axi_vdma_component name>/doc

This directory contains the appropriate product guide.

Table 6-2: Doc Directory

Name	Description
<project_dir>/<axi_vdma_component_name>/doc	
axi_vdma_v5_04_a_readme.txt axi_vdma_v5_04_a_readme_vinfo.html	The AXI VDMA release notes and core information file in text and html format.
pg020_axi_vdma.pdf	The AXI VDMA Product Guide.

[Back to Top](#)

<axi_vdma_component name>/hdl/src/vhdl

This directory contains AXI VDMA source files including the proc_common, AXI SG, AXI Data Mover helper library files.

Constraining the Core

This chapter contains information about constraining the core in the ISE® Design Suite environment.

In synchronous mode, `C_PRMRY_IS_ACLK_ASYNC = 0`, all clocks run at the same frequency and are derived from the same source. There are no multicycle or false paths in this design. All logic between flop-to-flop should meet timing within one clock period.

In asynchronous mode, `C_PRMRY_IS_ACLK_ASYNC = 1`, all clocks are treated asynchronously to each other and the core will write out appropriate clock domain crossing constraints.

Detailed Example Design

This chapter contains information about the provided example design in the ISE® Design Suite environment. For detailed information about available example designs for the VDMA core, see the Xilinx Application Notes, [XAPP739](#), [XAPP740](#), and [XAPP742](#). Also see [Triple Frame Buffer Example in Chapter 3](#).

SECTION IV: APPENDICES

[HBlank and VBlank Periods for Standard Frames](#)

[Migrating](#)

[Debugging](#)

[Additional Resources](#)

HBlank and VBlank Periods for Standard Frames

Figure A-1 shows one Full video frame, an Active window, and horizontal and vertical blanking of a 1080p standard frame. Table A-1 shows Horizontal blank and Vertical blank periods calculation for standard frame formats. This helps you align the fsync period for various frame formats.

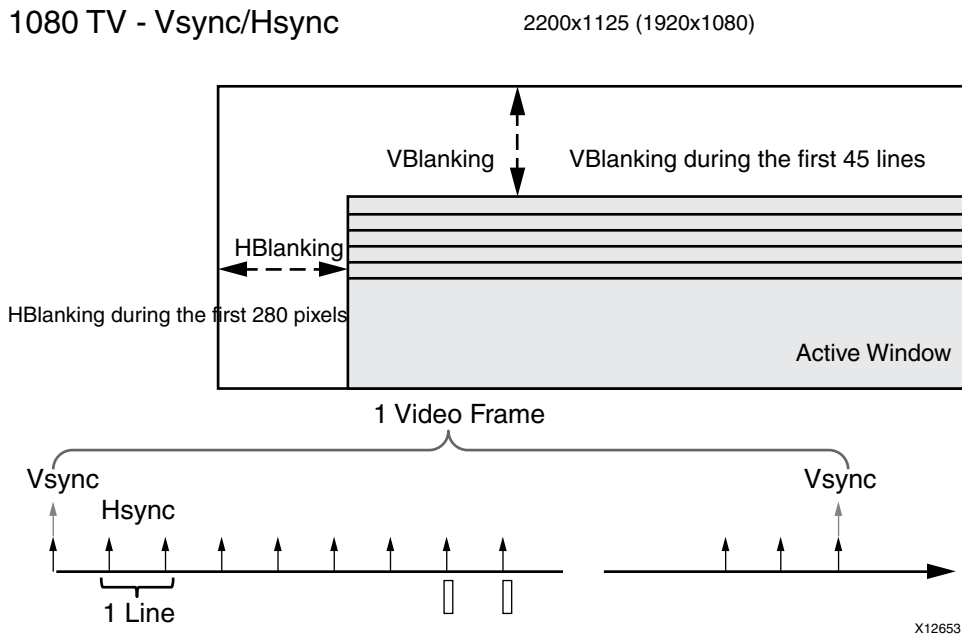

Figure A-1: Frame Format of 1080p

Table A-1: HBlank and VBlank of Various Standard Frames

	Video Display Standard	Total video format		Active video format		Nominal frame rate (Hz)	FSync or VSync period = 1/Nominal frame rate	HSync Period = FSync or Vsync period/Total number of video lines	Vertical Blank or VBlank = (Total -Active) Video Lines*Hsync Period	Pixel Period = Hsync Period/Total Number of pixels	Horizontal Blank or HBlank = (Total -Active) Pixels*Pixel Period
		Number of pixels	Number of Lines	Number of pixels	Number of Lines						
PAL interlaced	576i	864	625	720	576	25	40 ms	64 μ s	49*Hsync Period	0.074 μ s	144*Pixel Period
PAL progressive	576p	864	625	720	576	50	20 ms	32 μ s	49*Hsync Period	0.037 μ s	144*Pixel Period
NTSC interlaced	480i	858	525	720	480	30	33.33 ms	63.49 μ s	45*Hsync Period	0.074 μ s	138*Pixel Period
NTSC progressive	480p	858	525	720	480	60	16.66 ms	31.74 μ s	45*Hsync Period	0.037 μ s	138*Pixel Period
HD1080i	1080i	2200	1125	1920	1080	30	33.33 ms	26.63 μ s	45*Hsync Period	0.0134 μ s	200*Pixel Period
HD1080p	1080p	2200	1125	1920	1080	60	16.66 ms	14.81 μ s	45*Hsync Period	0.0067 μ s	200*Pixel Period

Migrating

No action is required when upgrading from v4_00_a, or later to latest version. However, when upgrading from v3_00_a to latest version, in EDK, remove the following VDMA parameters from the mhs file.

- c_s_axi_lite_aclk_freq_hz
- c_m_axi_mm2s_aclk_freq_hz
- c_m_axi_s2mm_aclk_freq_hz
- c_m_axi_sg_aclk_freq_hz

When upgrading from v3_00_a to latest version, manually connect streaming resets out provided by MM2S and S2MM channels if & as required (mm2s_prmry_reset_out_n, s2mm_prmry_reset_out_n).

Note: In v3_00_a these reset outputs were part of AXI-S streaming bus signals.

For Vivado™ and CORE™ Generator tools, there is an **UPGRADE IP** option available in the GUI that you can click to switch from v3_00_a, v4_00_a, v_5_00_a and v5_01_a to the latest version.

See *Vivado Design Suite Migration Methodology Guide* ([UG911](#)) for more information about migration.

Debugging

This appendix includes details about resources available on the Xilinx Support website and debugging tools. In addition, this appendix provides a step-by-step debugging process and a flow diagram to guide you through debugging the AXI VDMA core

The following topics are included in this appendix:

- [Finding Help on Xilinx.com](#)
- [Debug Tools](#)
- [Hardware Debug](#)

Finding Help on Xilinx.com

To help in the design and debug process when using the AXI VDMA core, the [Xilinx Support web page](#) (www.xilinx.com/support) contains key resources such as product documentation, release notes, answer records, information about known issues, and links for opening a Technical Support WebCase.

Documentation

This product guide is the main document associated with the AXI VDMA core. This guide, along with documentation related to all products that aid in the design process, can be found on the Xilinx Support web page (www.xilinx.com/support) or by using the Xilinx Documentation Navigator.

Download the Xilinx Documentation Navigator from the Design Tools tab on the Downloads page (www.xilinx.com/download). For more information about this tool and the features available, open the online help after installation.

Example Designs

For detailed information about available example designs for the VDMA core, see the Application Notes [XAPP739](#), [XAPP740](#), and [XAPP742](#). Also see [Triple Frame Buffer Example in Chapter 3](#).

Release Notes

Known issues for all cores, including the AXI VDMA core are described in the [IP Release Notes Guide \(XTP025\)](#).

Known Issues

Answer Records include information about commonly encountered problems, helpful information on how to resolve these problems, and any known issues with a Xilinx product. Answer Records are created and maintained daily ensuring that users have access to the most accurate information available.

Answer Records for this core are listed below, and can also be located by using the Search Support box on the main [Xilinx support web page](#). To maximize your search results, use proper keywords such as

- Product name
- Tool message(s)
- Summary of the issue encountered

A filter search is available after results are returned to further target the results.

Answer Records for the AXI VDMA Core

[52953](#) - AXI VDMA - What clock crossing constraints do I need to add for this core?

[47654](#) - Release Notes and Known Issues

Contacting Technical Support

Xilinx provides premier technical support for customers encountering issues that require additional assistance.

To contact Xilinx Technical Support:

1. Navigate to www.xilinx.com/support.
2. Open a WebCase by selecting the [WebCase](#) link located under Support Quick Links.

When opening a WebCase, include:

- Target FPGA including package and speed grade.
- All applicable Xilinx Design Tools and simulator software versions.
- Additional files based on the specific issue might also be required. See the relevant sections in this debug guide for guidelines about which file(s) to include with the WebCase.

Debug Tools

ChipScope Pro Tool

The ChipScope™ Pro debugging tool inserts logic analyzer, bus analyzer, and virtual I/O cores directly into your design. The ChipScope Pro debugging tool allows you to set trigger conditions to capture application and integrated block port signals in hardware. Captured signals can then be analyzed through the ChipScope Pro logic analyzer tool. For detailed information for using the ChipScope Pro debugging tool, see

www.xilinx.com/tools/cspro.htm.

Hardware Debug

Following are common issues that you can encounter:

1. AXI VDMA works, but the bottom few lines are not proper.

Most of these issues are attributed to wrong hsize and vsize programming in AXI VDMA. Double-check programmed values and check if fsync signals are connected and fsync period is maintained properly.

2. AXI VDMA locks up.



RECOMMENDED: *It is recommended to have `C_MM2S_SOF_ENABLE = 1`, `C_S2MM_SOF_ENABLE = 1`, `C_USE_FSYNC = 1` and `C_FLUSH_ON_FSYNC = 1` where AXI VDMA continues to work irrespective of datapath errors. Setting `C_S2MM_SOF_ENABLE = 1` also provides access to fsync cross-bar (FsyncSrcSelect: (bits[6:5] of S2MM_DMACR - offset 0x30h) through which different fsync sources can be selected.*

The following registers are implemented to help debug the failures:

- Bits 7(SOFEarlyErr), 8(EOLEarlyErr), 11(SOFLateErr) and 15(EOLLateErr) of offset 0x34h to identify error occurrence in S2MM path
- S2MM hsize status register (bits [15:0] of offset 0xF0h) captures incoming hsize count during EOLEarly error
- S2MM vsize status register (bits [12:0] of offset 0xF4h) captures incoming vsize count during SOFEarly error
- FRMPTR_STS register (offset 0x24h) captures current operating frame pointer status of both MM2S and S2MM channels.

3. Per VDMA park pointer register read, VDMA channel is not moving to next frame buffer.

Answer: VDMA park ptr register latches the frame_number value when any (line/frame) error happens. After the error bits are cleared, this register continuously updates the working frame numbers.

There is another register 0x24 added that reports the VDMA working frame number irrespective of errors.

4. When VDMA system is re-initialized through software, horizontal shift is observed onscreen.

Answer: This could be related to system reset release sequence and programming issues.

5. Channel does not come out from reset.

Answer: Check that all clocks related to the VDMA channel have proper connectivity & are running.

Additional Resources

Xilinx Resources

For support resources such as Answers, Documentation, Downloads, and Forums, see the Xilinx Support website at:

www.xilinx.com/support.

For a glossary of technical terms used in Xilinx documentation, see:

www.xilinx.com/company/terms.htm.

For a comprehensive listing of Video and Imaging application notes, white papers, reference designs and related IP cores, see the Video and Imaging Resources page at:

www.xilinx.com/esp/video/refdes_listing.htm

References

Unless otherwise noted, IP references are for the product documentation page. These documents provide supplemental material useful with this user guide:

1. *LogiCORE IP AXI Interconnect Product Guide* ([PG059](#))
2. *AXI Reference Guide* ([UG761](#))
3. *Vivado Design Suite Migration Methodology Guide* ([UG911](#))
4. [AMBA AXI4-Stream Protocol Specification](#)
5. [Vivado Design Suite - 2012.4 User Guides web page](#)
6. *AXI Multi-Ported Memory Controller* ([XAPP739](#))
7. *Designing High-Performance Video Systems with the AXI Interconnect* ([XAPP740](#))
8. *Designing High-Performance Video Systems in 7 Series FPGAs with the AXI Interconnect* ([XAPP741](#))
9. *AXI VDMA Reference Design* ([XAPP742](#))

To search for Xilinx documentation, go to www.xilinx.com/support.

Technical Support

Xilinx provides technical support at www.xilinx.com/support for this LogiCORE™ IP product when used as described in the product documentation. Xilinx cannot guarantee timing, functionality, or support of product if implemented in devices that are not defined in the documentation, if customized beyond that allowed in the product documentation, or if changes are made to any section of the design labeled DO NOT MODIFY.

Ordering Information

This Xilinx LogiCORE IP module is provided at no additional cost with the standard Xilinx ISE® Design Suite and ISE Embedded Edition (EDK) software under the terms of the [Xilinx End User License](#).

Information about this and other Xilinx LogiCORE IP modules is available at the [Xilinx Intellectual Property](#) page. For information on pricing and availability of other Xilinx LogiCORE IP modules and software, contact your [local Xilinx sales representative](#).

Revision History

The following table shows the revision history for this document.

Date	Version	Revision
10/19/11	1.0	Initial Xilinx release.
01/18/12	1.1	Summary of Major Core Changes Added 32 Frame Stores support Added Internal Genlock support Added Frame Sync on TUSER0 support Added additional stream data width support Summary of Major Documentation Changes Removed List of Acronym from Appendix. For the first occurrence of each acronym, spelled out full text. Added supported software drivers to IP Facts table. Created new section Scatter Gather Mode. Reordered the hierarchy of the Register Space section. Reordered the hierarchy of the Designing with the Core section. Added the new section, Triple Frame Buffer Example. Added new Appendix, HBlank and VBlank Periods for Standard Frames
04/24/12	1.2	Summary of Major Core Changes Added independent fsync control for both MM2S and S2MM channels Added Dynamic Genlock support
07/25/12	1.3	Updated to core version 5.02.a and 14.2 ISE tools. Added Vivado tools and Zynq™-7000 support. Updated Error section. Updated many items in the IP Facts table. Added Additional Design section.

Date	Version	Revision
10/16/12	1.4	Updated to core version 5.03a and 14.3 ISE tools. Updated debugging appendix.
12/18/12	1.5	<ul style="list-style-type: none"> • Updated to core version 5.04a, Vivado Design Suite 2012.4, ISE Design Suite, Embedded Edition v14.4, and ISE Design Suite v14.4. • Replaced Figure 1-1 and Figure 1-2 with a single new figure. • Removed Scatter Gather Mode section and replaced with new paragraph. • Updated devices in Table 2-1, Maximum Frequencies • Updated Table 2-4 and 2-5, resource tables • Removed Figure 3-1, Figure 3-3, Figure 3-13, Figure 3-14, and Figure 3-15 • Removed C_S_AXIS_S2MM_TUSER_BITS parameter • Added C_DYNAMIC_RESOLUTION parameter • Removed Dynamic Line Buffer Threshold section. • Updated GUI screen captures. • Added material about Genlock synchronization. • Updated output hierarchy. • Updated Debugging appendix

Notice of Disclaimer

The information disclosed to you hereunder (the "Materials") is provided solely for the selection and use of Xilinx products. To the maximum extent permitted by applicable law: (1) Materials are made available "AS IS" and with all faults, Xilinx hereby DISCLAIMS ALL WARRANTIES AND CONDITIONS, EXPRESS, IMPLIED, OR STATUTORY, INCLUDING BUT NOT LIMITED TO WARRANTIES OF MERCHANTABILITY, NON-INFRINGEMENT, OR FITNESS FOR ANY PARTICULAR PURPOSE; and (2) Xilinx shall not be liable (whether in contract or tort, including negligence, or under any other theory of liability) for any loss or damage of any kind or nature related to, arising under, or in connection with, the Materials (including your use of the Materials), including for any direct, indirect, special, incidental, or consequential loss or damage (including loss of data, profits, goodwill, or any type of loss or damage suffered as a result of any action brought by a third party) even if such damage or loss was reasonably foreseeable or Xilinx had been advised of the possibility of the same. Xilinx assumes no obligation to correct any errors contained in the Materials or to notify you of updates to the Materials or to product specifications. You may not reproduce, modify, distribute, or publicly display the Materials without prior written consent. Certain products are subject to the terms and conditions of the Limited Warranties which can be viewed at <http://www.xilinx.com/warranty.htm>; IP cores may be subject to warranty and support terms contained in a license issued to you by Xilinx. Xilinx products are not designed or intended to be fail-safe or for use in any application requiring fail-safe performance; you assume sole risk and liability for use of Xilinx products in Critical Applications: <http://www.xilinx.com/warranty.htm#critapps>.

© Copyright 2010–2012 Xilinx, Inc. Xilinx, the Xilinx logo, Artix, ISE, Kintex, Spartan, Virtex, Vivado, Zynq, and other designated brands included herein are trademarks of Xilinx in the United States and other countries. AMBA is a registered trademark of ARM in the EU and other countries. All other trademarks are the property of their respective owners.