

Vivado Design Suite

AXI Reference Guide

UG1037 (v4.0) July 15, 2017

Revision History

The following table shows the revision history for this document.

Date	Version	Revision
07/15/2017	4.0	<p>Updated to match the new Vivado "Look and Feel".</p> <p>Updated all IP to reflect current features.</p> <p>Added Zynq UltraScale+ MPSoC Processor Device in Chapter 3.</p> <p>Added AXI SmartConnect IP in Chapter 3, and mention of SmartConnect IP capabilities throughout the document.</p> <p>Added AXI Verification IP in Chapter 3.</p> <p>Added AXI4-Stream Verification IP in Chapter 3.</p> <p>Added Zynq-7000 AP SoC Verification IP in Chapter 3.</p>
06/24/2015	3.0	<p>Added Quick Take Videos.</p> <p>Updated the AXI IP Catalog Figure 2-1.</p> <p>Updated the IP Project Settings Packaging tab in Figure 2-6.</p> <p>Changed Features and Limitations in AXI Infrastructure IP Cores.</p> <p>Updated Vivado Lab Tools to Vivado Lab Edition throughout the document.</p> <p>Added XAPP1231 document reference to additional resources.</p> <p>Added direct links to destinations.</p>
11/20/2014	2.1	<p>Corrected AWCACHE and ARCACHE for AXI4-Lite to "Signal not present" in Appendix A, Write Data Channel Signals and Appendix A, Read Data Channel Signals.</p>
11/19/2014	2.0	<p>Changed:</p> <p>IP Interoperability. Using Vivado AXI IP in RTL Projects.</p> <p>Using the Create and Package IP Wizard for AXI IP.</p> <p>Using Vivado IP Integrator to Assemble AXI IP.</p> <p>Adding AXI IP to the IP Catalog Using Vivado IP Packager.</p> <p>Using AXI IP in System Generator for DSP.</p> <p>Added:</p> <p>Adding AXI Interfaces Using High Level Synthesis.</p> <p>AXI Virtual FIFO Controller. DataMover</p> <p>Simulating IP. Using Debug and IP.</p> <p>Performance Monitor IP. AXI BFM.</p> <p>Bus Functional Models.</p> <p>Choosing a Programmable Logic Interface.</p> <p>Zynq-7000 All Programmable SoC Processor IP.</p> <p>MicroBlaze Processor.</p> <p>Added: Migrating to AXI for IP Cores.</p> <p>Migrating to AXI for IP Cores.</p> <p>Migrating HDL Designs to use DSP IP with AXI4-Stream.</p> <p>Migrating IP Using the Vivado Create and Package Wizard.</p> <p>High End Verification Solutions.</p> <p>Added Optimizing AXI on Zynq-7000 AP SoC Processors.</p>
04/02/2014	1.0	<p>Initial release of Vivado AXI Reference Guide.</p>

Table of Contents

Chapter 1: Introducing AXI for Vivado

Overview	5
What is AXI?	5
Summary of AXI4 Benefits	6
How AXI Works	6
IP Interoperability	10
Quick Take Videos	11

Chapter 2: AXI Support in Xilinx Tools and IP

Introduction	12
Using Vivado AXI IP in RTL Projects	12
Using the Create and Package IP Wizard for AXI IP	14
Adding AXI IP to the IP Catalog Using Vivado IP Packager	19
Using Vivado IP Integrator to Assemble AXI IP	21
Using AXI IP in System Generator for DSP	22
Adding AXI Interfaces Using High Level Synthesis	25

Chapter 3: Samples of Vivado AXI IP and Xilinx Processors

Overview	30
AXI Infrastructure IP Cores	30
AXI4 DMA	49
Simulating IP	55
Using Debug and IP	56
Zynq UltraScale+ MPSoC Processor Device	67
Zynq-7000 All Programmable SoC Processor IP	68
MicroBlaze Processor	72

Chapter 4: AXI Feature Adoption in Xilinx Devices

Introduction	80
Memory-Mapped IP Feature Adoption and Support	80
AXI4-Stream Adoption and Support	82
DSP and Wireless IP: AXI Feature Adoption	94
Video IP: AXI Feature Adoption	95

Chapter 5: Migrating to Xilinx AXI Protocols

Introduction	110
Migrating to AXI for IP Cores.....	110
Migrating IP Using the Vivado Create and Package Wizard	111
Using System Generator for DSP for Migrating IP	111
Migrating a Fast Simplex Link to AXI4-Stream.....	112
Migrating HDL Designs to use DSP IP with AXI4-Stream.....	114
High End Verification Solutions.....	117

Chapter 6: AXI System Optimization: Tips and Hints

Introduction	118
AXI System Optimization.....	122
AXI4-based Vivado Multi-Ported Memory Controller: AXI4 System Optimization Example	126
Common Pitfalls Leading to AXI Systems of Poor Quality Results	142
Optimizing AXI on Zynq-7000 AP SoC Processors	145

Chapter 7: AXI4-Stream IP Interoperability: Tips and Hints

Introduction	148
Key Considerations	148
Domain Usage Guidelines and Conventions	151
Domain-Specific Data Interpretation and Interoperability Guidelines	155

Appendix A: AXI Adoption Summary

Introduction	162
Global Signals.....	162
AXI4 and AXI4-Lite Signals.....	163
AXI4-Stream Signal Summary	167

Appendix B: AXI Terminology

Terminology	168
-------------------	-----

Appendix C: Additional Resources and Legal Notices

Xilinx Resources	172
Solution Centers.....	172
Documentation Navigator and Design Hubs	172
Third-Party Documentation	173
Xilinx Documentation	173
Vivado Design Suite Video Tutorials.....	175
Please Read: Important Legal Notices	175

Introducing AXI for Vivado

Overview

Xilinx adopted the Advanced eXtensible Interface (AXI) protocol for Intellectual Property (IP) cores beginning with the Xilinx® Spartan®-6 and Virtex®-6 devices. Xilinx continues the use of the AXI protocol for IP targeting the UltraScale™ architecture, 7 series, and Zynq®-7000 All Programmable (AP) SoC devices.

This document is intended to: Introduce key concepts of the AXI protocol.

- Give an overview of what Xilinx tools you can use to create AXI-based IP.
- Explain what features of AXI that have been adopted by Xilinx.
- Provide guidance on how to migrate your existing design to AXI.

Note: This document is not intended to replace the advanced micro controller bus architecture (AMBA®) ARM® AXI4 specifications. Before beginning an AXI design, you need to download, read, and understand the *AMBA AXI and ACE Protocol Specification*, along with the *AMBA4 AXI4-Stream Protocol*. You might need to fill out a brief registration before downloading the documents. See the *AMBA website* [Ref 1].

Note: The ACE portion of the AMBA specification is generally not used, except in special cases such as the connection between a MicroBlaze™ processor and its associated system cache block.

What is AXI?

AXI is part of ARM AMBA, a family of micro controller buses first introduced in 1996. The first version of AXI was first included in AMBA 3.0, released in 2003. AMBA 4.0, released in 2010, includes the second major version of AXI, AXI4.

There are three types of AXI4 interfaces:

- **AXI4:** For high-performance memory-mapped requirements.
- **AXI4-Lite:** For simple, low-throughput memory-mapped communication (for example, to and from control and status registers).
- **AXI4-Stream:** For high-speed streaming data.

Xilinx introduced these interfaces in the ISE® Design Suite, release 12.3. Xilinx continues to use and support AXI and AXI4 interfaces in the Vivado® Design Suite.

Summary of AXI4 Benefits

AXI4 is widely adopted in Xilinx product offerings, providing benefits to *Productivity*, *Flexibility*, and *Availability*:

- **Productivity:** By standardizing on the AXI interface, developers need to learn only a single protocol for IP.
- **Flexibility:** Providing the right protocol for the application:
 - AXI4 is for memory-mapped interfaces and allows high throughput bursts of up to 256 data transfer cycles with just a single address phase.
 - AXI4-Lite is a light-weight, single transaction memory-mapped interface. It has a small logic footprint and is a simple interface to work with both in design and usage.
 - AXI4-Stream removes the requirement for an address phase altogether and allows unlimited data burst size. AXI4-Stream interfaces and transfers do not have address phases and are therefore not considered to be memory-mapped.
- **Availability:** By moving to an industry-standard, you have access not only to the Vivado IP Catalog, but also to a worldwide community of ARM partners.
 - Many IP providers support the AXI protocol.
 - A robust collection of third-party AXI tool vendors is available that provide many verification, system development, and performance characterization tools. As you begin developing higher performance AXI-based systems, the availability of these tools is essential.

How AXI Works

This section provides a brief overview of how the AXI interface works. Consult the *AMBA AXI specifications* [Ref 1] for the complete details on AXI operation.

The AXI specifications describe an interface between a single AXI master and AXI slave, representing IP cores that exchange information with each other. Multiple memory-mapped AXI masters and slaves can be connected together using AXI infrastructure IP blocks. The Xilinx AXI Interconnect IP and the newer AXI SmartConnect IP contain a configurable number of AXI-compliant master and slave interfaces, and can be used to route transactions between one or more AXI masters and slaves.

The AXI Interconnect is architected using a traditional, monolithic crossbar approach; described in [AXI Infrastructure IP Cores in Chapter 3](#). The newer SmartConnect IP, which was production released in 2017.1, contains a more scalable and flexible Network-on-Chip (NoC) architecture and is described in [Xilinx AXI SmartConnect and AXI Interconnect IP in Chapter 3](#).

Both AXI4 and AXI4-Lite interfaces consist of five different channels:

- Read Address Channel
- Write Address Channel
- Read Data Channel
- Write Data Channel
- Write Response Channel

Data can move in both directions between the master and slave simultaneously, and data transfer sizes can vary. The limit in AXI4 is a burst transaction of up to 256 data transfers. AXI4-Lite allows only one data transfer per transaction.

The following figure shows how an AXI4 read transaction uses the read address and read data channels.

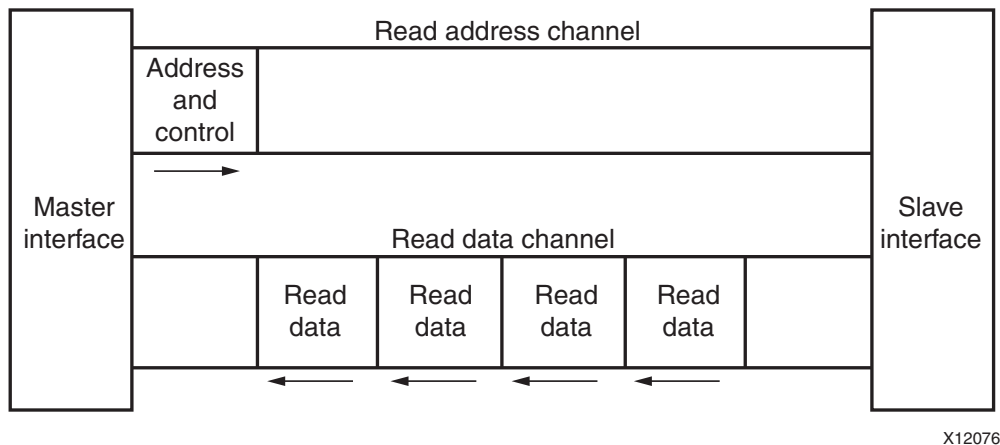

X12076

Figure 1-1: Channel Architecture of Reads

Figure 1-2 shows how a write transaction uses the write address, write data, and write response channels.

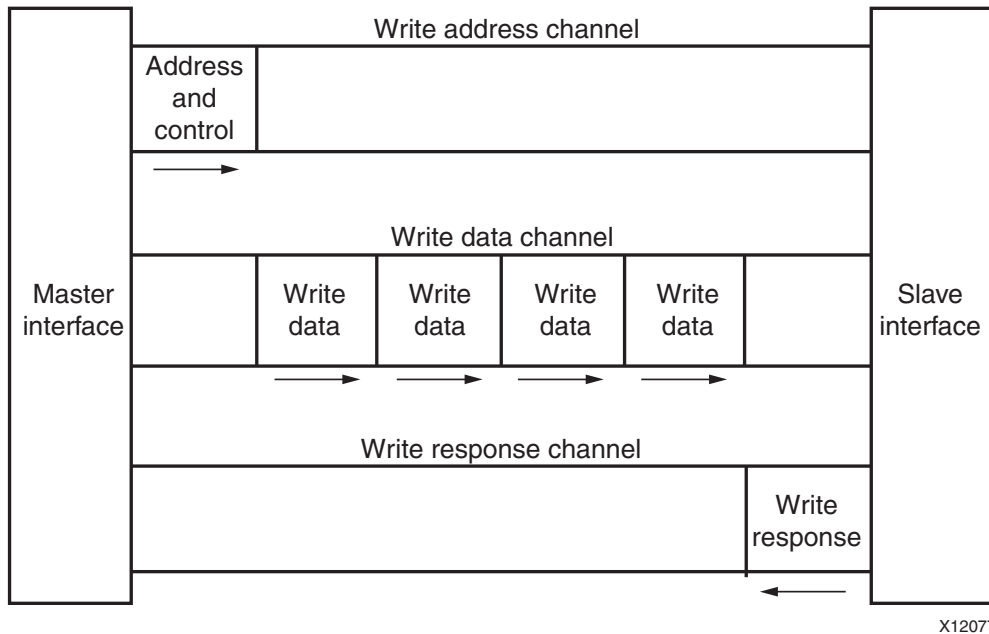

Figure 1-2: Channel Architecture of Writes

As shown in the preceding figures, AXI4:

- Provides separate data and address connections for reads and writes, which allows simultaneous, bidirectional data transfer.
- Requires a single address and then bursts up to 256 words of data.

The AXI4 protocol describes options that allow AXI4-compliant systems to achieve very high data throughput. Some of these features, in addition to bursting, are: data upsizing and downsizing, multiple outstanding addresses, and out-of-order transaction processing.

At a hardware level, AXI4 allows systems to be built with a different clock for each AXI master-slave pair. In addition, the AXI4 protocol allows the insertion of register slices (often called pipeline stages) to aid in timing closure.

AXI4-Lite is similar to AXI4 with some exceptions: The most notable exception is that bursting is not supported. The AXI4-Lite chapter of the *ARM AMBA AXI Protocol Specification* [Ref 1] describes the AXI4-Lite protocol in more detail.

The AXI4-Stream protocol defines a single channel for transmission of streaming data. The AXI4-Stream channel models the write data channel of AXI4. Unlike AXI4, AXI4-Stream interfaces can burst an unlimited amount of data. There are additional, optional capabilities described in the *AMBA4 AXI4-Stream Protocol Specification* [Ref 1]. The specification describes how you can split, merge, interleave, upsize, and downsize AXI4-Stream compliant interfaces.



IMPORTANT: Unlike AXI4, you cannot reorder AXI4-Stream transfers.

- **Memory-Mapped Protocols:** In memory-mapped protocols (AXI3, AXI4, and AXI4-Lite), all transactions involve the concept of transferring a target address within a system memory space and data.

Memory-mapped systems often provide a more homogeneous way to view the system, because the IP operates around a defined memory map.

AXI3-based IP can be integrated into AXI4-based systems for interoperability, however most Xilinx IP natively adopt AXI4 which contains protocol enhancements compared to AXI3.

Note: The processing system block in the Zynq-7000 AP SoC devices use AXI3 memory-mapped interfaces. AXI3 is a subset of AXI4 and Xilinx tools automatically insert the necessary adaptation logic to translate between AXI3 and AXI4.

- **AXI4-Stream Protocol:** Use the AXI4-Stream protocol for applications that typically focus on a data-centric and data-flow paradigm where the concept of an address is not present or not required. Each AXI4-Stream acts as a single unidirectional channel with a handshaking data flow.

At this lower level of operation (compared to the memory-mapped protocol types), the mechanism to move data between IP is defined and efficient, but there is no unifying address context between IP. The AXI4-Stream IP can be better optimized for performance in data flow applications, but also tends to be more specialized around a given application space.

- **Infrastructure IP:** An infrastructure IP is a building block used to help assemble systems. Infrastructure IP tends to be a generic IP that moves or transforms data around the system using general-purpose AXI4 interfaces and does not interpret data.

Examples of infrastructure IP are:

- AXI Register slices (for pipelining)
- AXI FIFOs (for buffering/clock conversion)
- AXI Interconnect IP and AXI SmartConnect IP (for connecting memory-mapped IP together)
- AXI Direct Memory Access (DMA) engines (for memory-mapped to stream conversion)
- AXI Performance Monitors and Protocol Checkers (for analysis and debug)
- AXI Verification IP (for simulation-based verification and performance analysis)

These IP are useful for connecting IP together into a system, but are not generally endpoints for data.

Combining AXI4-Stream and Memory-Mapped Protocols

A common approach is to build systems that combine AXI4-Stream and AXI memory-mapped IP together. Often a DMA engine can be used to move streams in and out of memory.

For example, a processor can work with DMA engines to decode packets or implement a protocol stack on top of the streaming data to build more complex systems where data moves between different application spaces or different IP.

IP Interoperability

The AXI specification provides a framework that defines protocols for moving data between IP using a defined signaling standard. This standard ensures that IP can exchange data with each other and that data can be moved across a system.

AXI IP interoperability affects:

- The IP application space
- How the IP interprets data
- Which AXI interface protocol is used (AXI4, AXI4-Lite, or AXI4-Stream)

The AXI protocol defines how data is exchanged, transferred, and transformed. The AXI protocol also ensures an efficient, flexible, and predictable means for transferring data.

Data Interpretation



IMPORTANT: *The AXI protocol does not specify or enforce the interpretation of data; therefore, you need to understand the data contents, and the different IP must have a compatible interpretation of the data.*

For IP such as a general purpose processor with an AXI4 memory-mapped interface, there is a great degree of flexibility in how to program a processor to format and interpret data as required by the Endpoint IP.

IP Compatibility

For more application-specific IP, like an Ethernet MAC (EMAC) or a Video Display IP using AXI4-Stream, the compatibility of the IP is more limited to their respective application spaces. For example, directly connecting an Ethernet MAC to the Video Display IP is not feasible.

Note: Even though two IP, such as EMAC and Video Streaming, can theoretically exchange data with each other, they would not function together because the two IP interpret bit fields and data packets in a completely different manner.

AXI4-Stream IP Interoperability

Chapter 7, “AXI4-Stream IP Interoperability: Tips and Hints,” provides an overview of the main elements and steps for building an AXI4-Stream system with interoperable IP. These key elements include understanding the AXI protocol, learning domain specific usage guidelines, using AXI infrastructure IP as system building blocks, and validating the final result. You can be most effective if you follow these steps:

1. Review the AXI4 documents:
 - *AMBA4 AXI4-Stream Protocol Specification* [Ref 1]
 - *LogiCORE IP AXI Interconnect IP Product Guide* (PG059) [Ref 12]
 - *LogicCORE IP AXI SmartConnect Product Guide* (PG247) [Ref 23]
 - [Chapter 7, “AXI4-Stream IP Interoperability: Tips and Hints.”](#)
 - *LogicCore IP AXI4-Stream Interconnect Product Guide* (PG085) [Ref 14]
2. Understand IP domains:
 - Review data types and layered protocols in [Chapter 7, “AXI4-Stream IP Interoperability: Tips and Hints.”](#)
 - Review the list of AXI IP available at: the Xilinx IP Center *website* [Ref 3].
 - Understand the domain-level guidelines described in [Domain Usage Guidelines and Conventions in Chapter 7](#).
3. Use the following steps when creating your system:
 - a. Configure IP to share compatible data types and protocols.
 - b. Use Infrastructure IP or converters where necessary.
 - c. Validate the system.

Quick Take Videos

The following quick take videos provide more information about using the AXI protocol with the Vivado Design Suite and other Xilinx development tools:



VIDEOS:

[Vivado Design Suite QuickTake Video: Targeting Zynq Devices Using Vivado IP Integrator](#)

[Vivado Design Suite QuickTake Video: Designing with Vivado IP Integrator](#)

[Vivado Design Suite QuickTake Video: Targeting Zynq Devices Using Vivado IP Integrator](#)

AXI Support in Xilinx Tools and IP

Introduction

This chapter describes how you can use Xilinx® tools to deploy individual pieces of AXI IP or to build systems of interconnected Xilinx AXI IP (using the Vivado® IP integrator in the Vivado® Design Suite).

Using Vivado AXI IP in RTL Projects

In the Vivado Integrated Development Environment (IDE), you can access Xilinx IP with an AXI4 interface directly from the Vivado IP Catalog and instantiate that IP directly into an register transfer logic (RTL) design ([Figure 2-1](#)).

Name	AXI4	Status	License	VLNV
Debug & Verification				
Debug				
JTAG to AXI Master	AXI4	Production	Included	xilinx.com:ip:jtag_axi:1.2
ILA (Integrated Logic Analyzer)	AXI4, AXI4-Stream	Production	Included	xilinx.com:ip:ila:6.2
AXI Infrastructure				
AXI4-Stream Interconnect		Production	Included	xilinx.com:ip:axis_interconnect:2.1
AXI Interconnect		Production	Included	xilinx.com:ip:axi_interconnect:2.1
AXI Data FIFO	AXI4	Production	Included	xilinx.com:ip:axi_data_fifo:2.1
AXI Clock Converter	AXI4	Production	Included	xilinx.com:ip:axi_clock_converter:2.1
AXI SmartConnect	AXI4	Production	Included	xilinx.com:ip:smartconnect:1.0
AXI Crossbar	AXI4	Production	Included	xilinx.com:ip:axi_crossbar:2.1
AXI Central Direct Memory Access	AXI4	Production	Included	xilinx.com:ip:axi_cdma:4.1
AXI Protocol Converter	AXI4	Production	Included	xilinx.com:ip:axi_protocol_converter:2.1
AXI Register Slice	AXI4	Production	Included	xilinx.com:ip:axi_register_slice:2.1
AXI Interconnect RTL	AXI4	Production	Included	xilinx.com:ip:axi_interconnect:1.7
AXI Verification IP	AXI4	Production	Included	xilinx.com:ip:axi_vip:1.0
AXI Protocol Checker	AXI4	Production	Included	xilinx.com:ip:axi_protocol_checker:1.1
AXI Data Width Converter	AXI4	Production	Included	xilinx.com:ip:axi_dwidth_converter:2.1
AXI MMU	AXI4	Production	Included	xilinx.com:ip:axi_mmu:2.1
AXI4-Stream Accelerator Adapter	AXI4, AXI4-Stream	Production	Included	xilinx.com:ip:axis_accelerator_adapter:2.1
AXI Direct Memory Access	AXI4, AXI4-Stream	Production	Included	xilinx.com:ip:axi_dma:7.1
AXI Memory Mapped to Stream Mapper	AXI4, AXI4-Stream	Production	Included	xilinx.com:ip:axi_mm2s_mapper:1.1
AXI4-Stream Switch	AXI4, AXI4-Stream	Production	Included	xilinx.com:ip:axis_switch:1.1
AXI Virtual FIFO Controller	AXI4, AXI4-Stream	Production	Included	xilinx.com:ip:axi_vfifo_ctrl:2.0

Figure 2-1: IP Catalog in Xilinx Tools

In the IP catalog, the **AXI4** column shows IP with AXI4 interfaces that are supported and displays the which interfaces are supported by the IP interface: AXI4 (memory-mapped), AXI4-Stream, or none.

Xilinx IP are designed to support AXI where applicable. For more information about using IP from the Vivado IP catalog in an RTL flow, see the *Vivado Design Suite User Guide: Designing with IP* (UG896) [Ref 30].

Using the Create and Package IP Wizard for AXI IP

The Vivado IDE provides a Create and Package IP wizard that takes you through all the required steps and settings for AXI IP. To create and package new IP:

1. From the **Tools** menu, select **Create and Package IP**, as shown in the following figure.

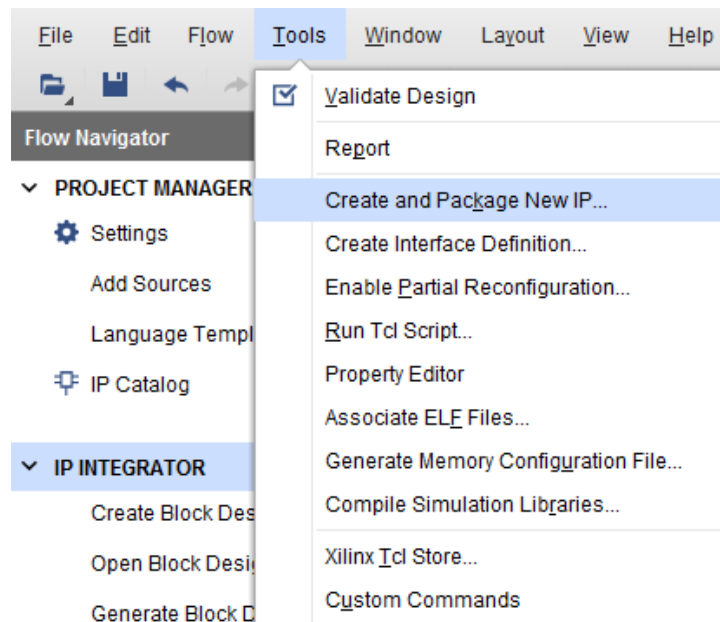

Figure 2-2: Create and Package IP Option

The Create And Package IP wizard opens, as shown in [Figure 2-3](#).

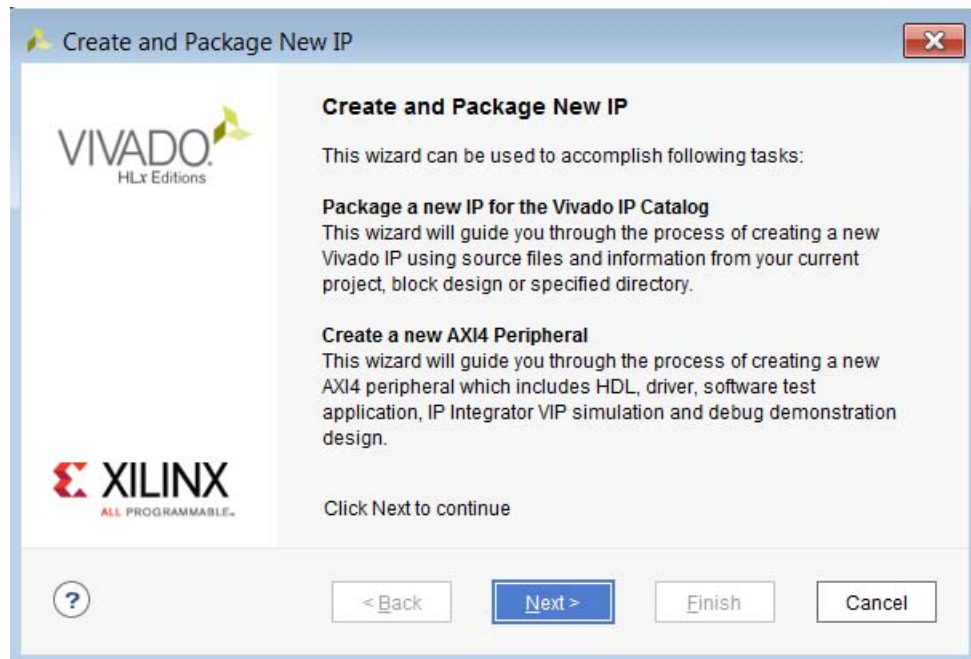

Figure 2-3: Create and Package IP Dialog Box

2. Select **Create a new AXI4 Peripheral**, to create a template AXI4 peripheral that includes HDL, drivers, a test application, and a BFM example template.
3. Click **Next**.

The Choose Create Peripheral or Package IP page opens, as shown in [Figure 2-4](#).

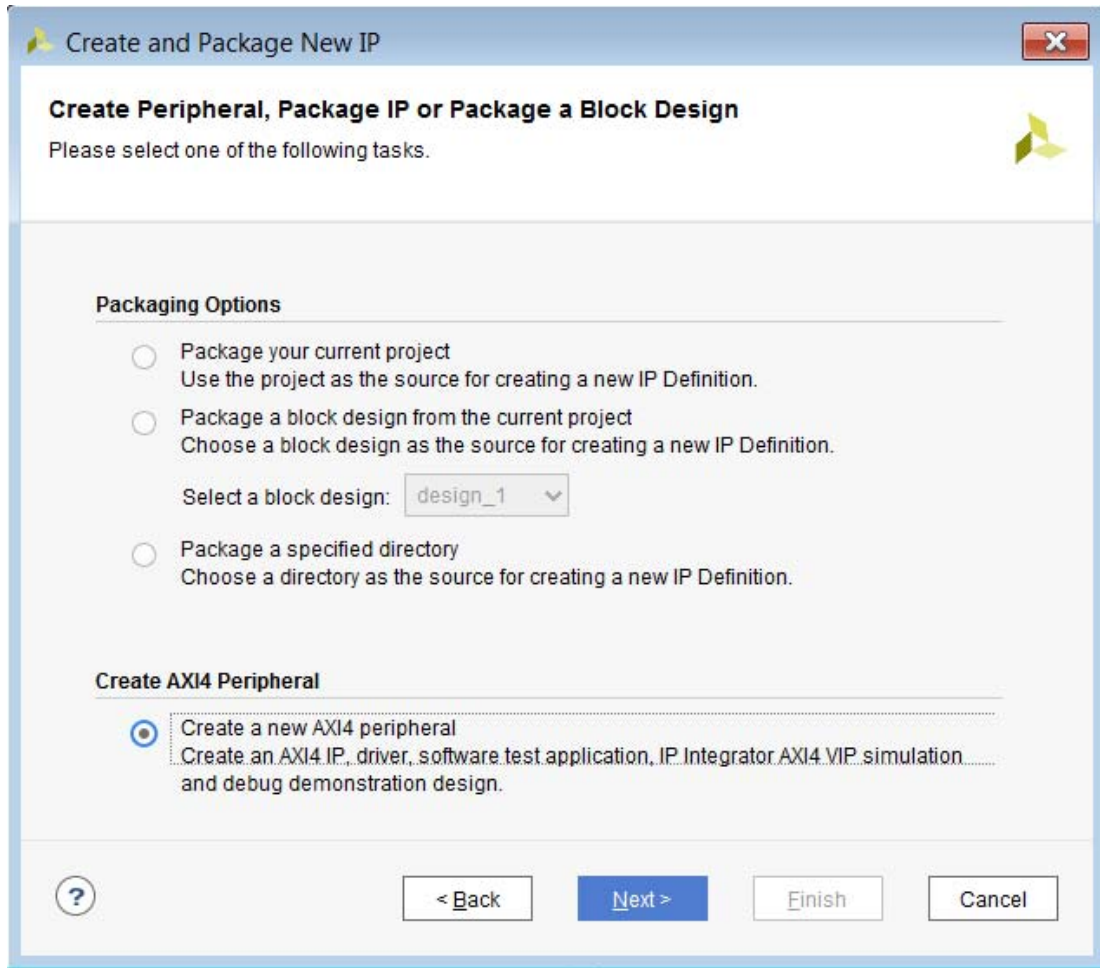

Figure 2-4: Choose Create or Package IP Dialog Box

4. Click **Next**.

The Peripheral Details page opens.

5. Enter the IP details in the Peripheral Details page, as shown in [Figure 2-5](#).

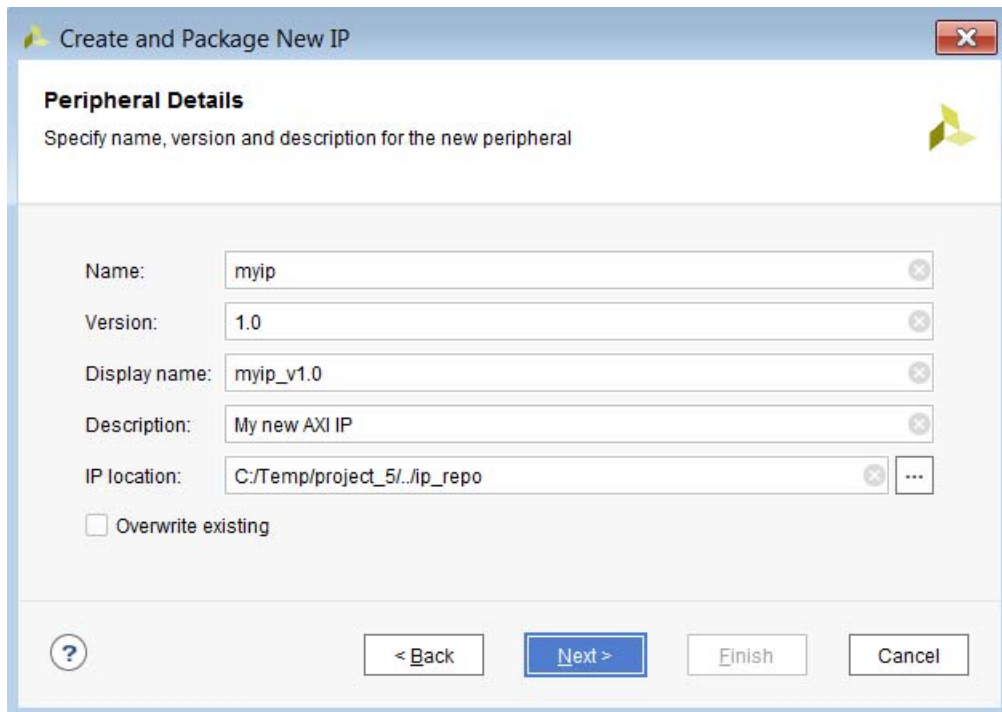

Figure 2-5: IP Details

The **Display Name** you provide shows in the Vivado IP catalog.

You can have different names in the **Name** and **Display Name** fields; any change in **Name** reflects automatically in the **Display Name**, which is concatenated with the **Version** field.

6. Click **Next**.
7. Select the IP location where you want the IP to be located.

The Vivado IP tool adds the location automatically to the IP repository list.

8. Click **Next**.

9. Add interfaces to your IP based on the functionality and the required AXI type, as shown in the following figure.

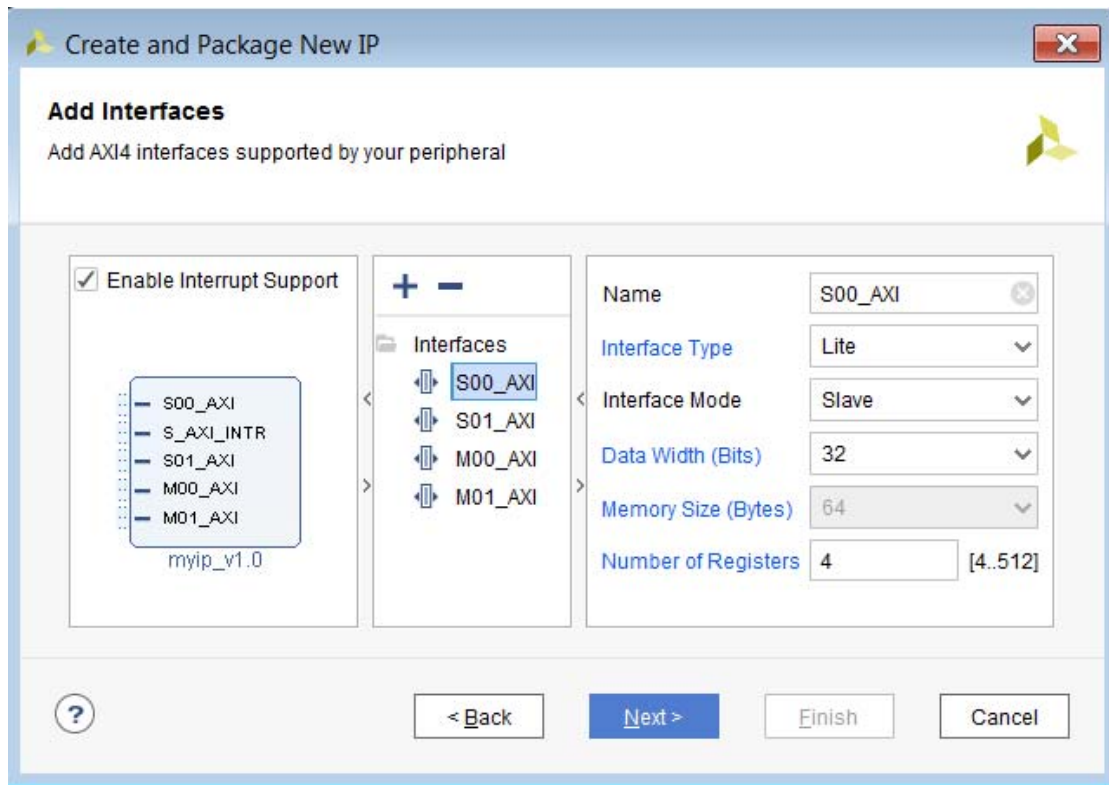

Figure 2-6: Create and Package New IP

10. To include interrupts to be available in your IP, check the **Enable Interrupt Support** check box.

The IP that this example shows would support edge or level interrupt (generated locally on the counter), which can be extended to input ports by user and IRQ output.

The data width and the number of registers vary, based on the AXI4 selection type.

11. Click **Next** and review your selections.

The final page of the wizard lists the details of your IP, as shown in [Figure 2-7](#).

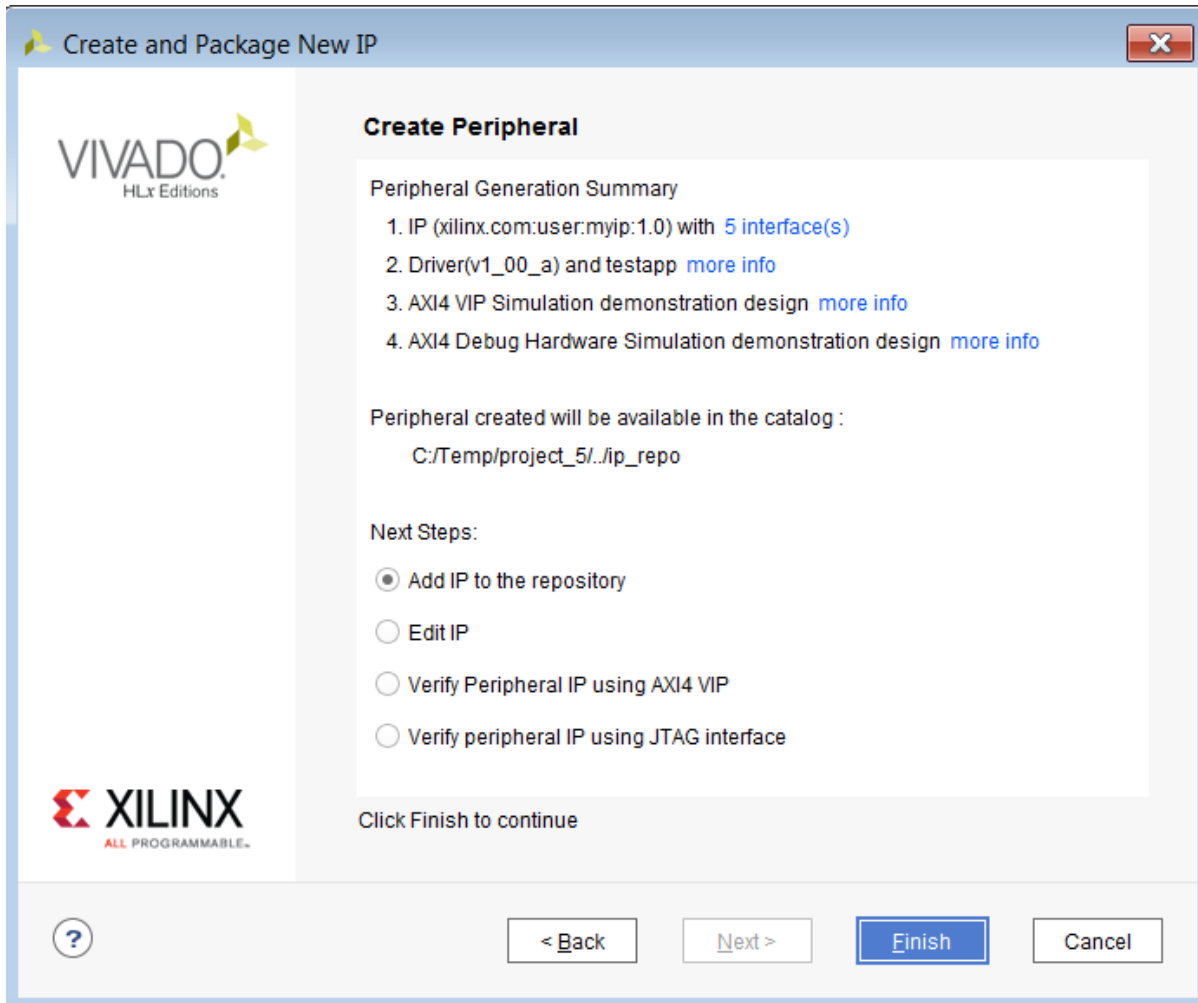

Figure 2-7: Create Peripheral Summary Page

After you generate the IP, additional options are available.

See the *Vivado Design Suite User Guide: Creating and Packaging Custom IP* (UG1118) [Ref 30] for more information regarding creating and packaging AXI IP.

Adding AXI IP to the IP Catalog Using Vivado IP Packager

The Vivado IP packager tool, shown in Figure 2-8, lets you prepare a design for use in the Vivado IP catalog. You can then instantiate this IP into a design in the Vivado Design Suite using the Vivado IP integrator.

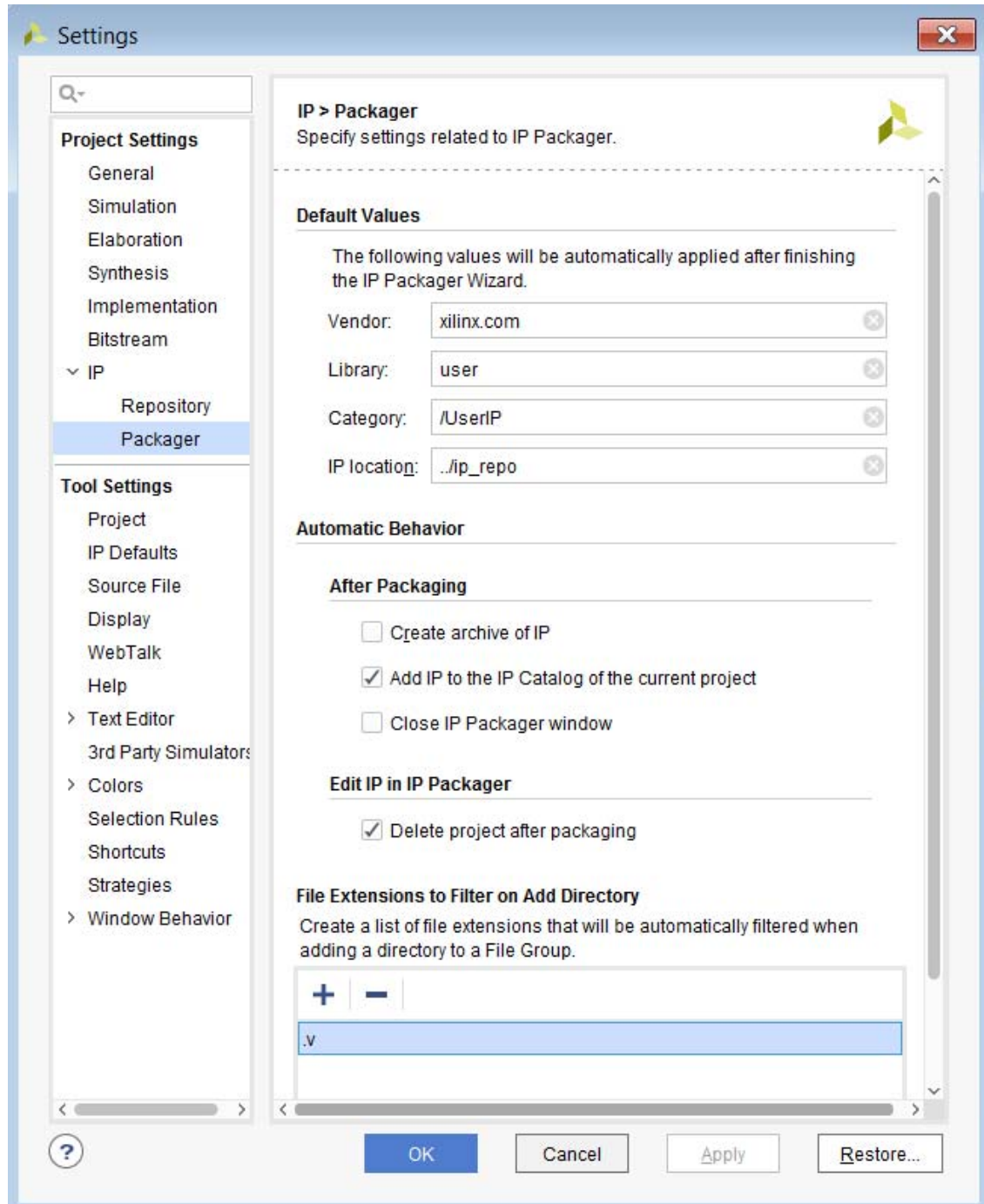

Figure 2-8: Vivado IP Packager Tool

When you use the Vivado Design Suite IP packaging flow for IP development, you have a more consistent user experience, better tool integration, and greater facilitation for reuse of the IP design in the Vivado IDE. The IP packager is AXI-aware, and can auto-recognize AXI signals. See [Appendix A, AXI Adoption Summary](#), for a summary of the Xilinx AXI adoption per signal.

See the following documents for more information:

- *Vivado Design Suite User Guide: Designing IP Subsystems Using IP Integrator* (UG994) [Ref 38]
- *Vivado Design Suite User Guide: Creating and Packaging Custom IP* (UG1118) [Ref 41]

Using Vivado IP Integrator to Assemble AXI IP

The Vivado IP integrator feature lets you create complex system designs by instantiating and interconnecting IP from the Vivado IP Catalog on a design block. You can create designs interactively through the IP integrator GUI or programmatically through a Tcl programming interface.

The Vivado IP integrator interprets AXI4 and AXI4-Stream interfaces, allowing you to construct designs at the interface level (for enhanced productivity). See the following figure.

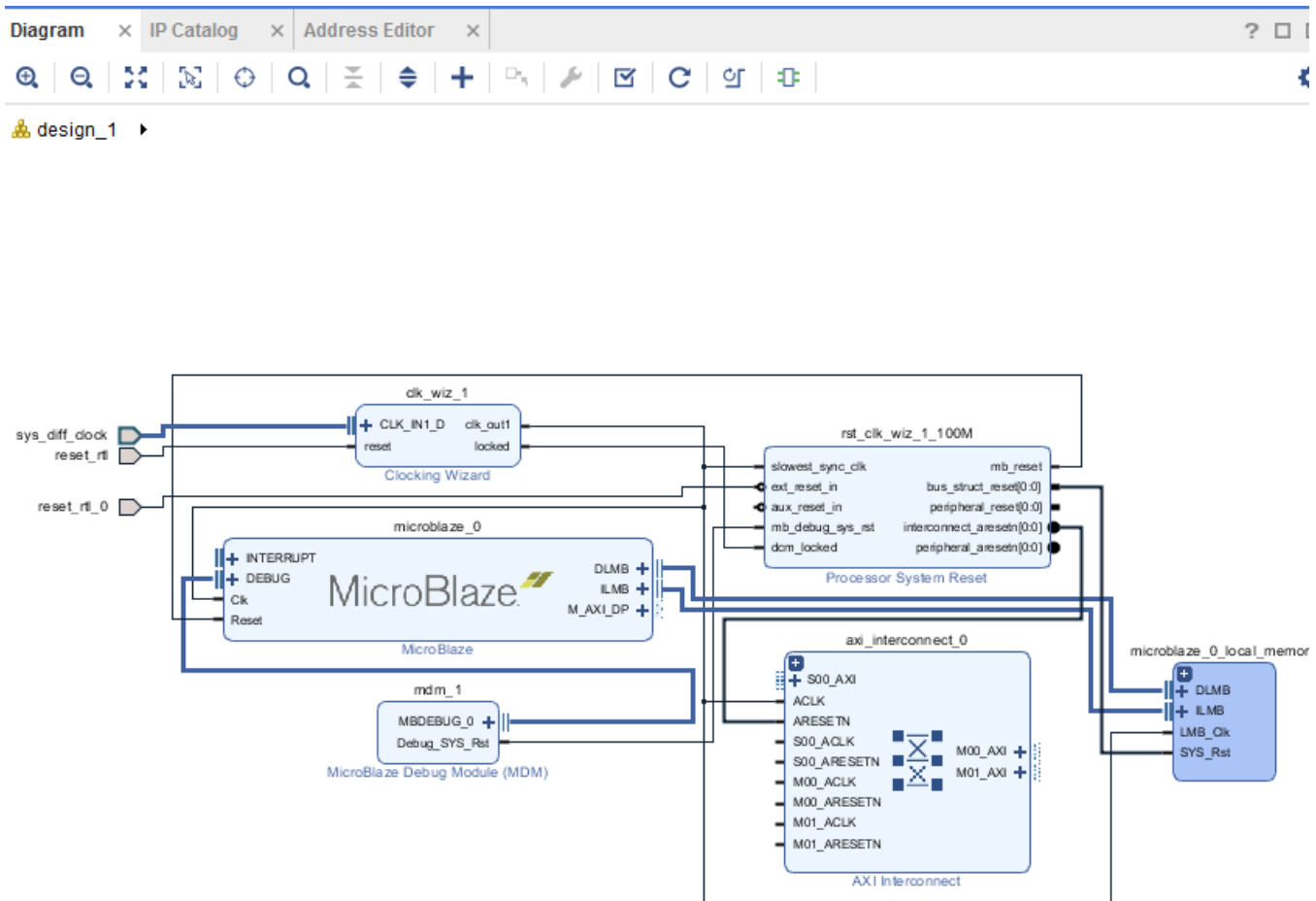

Figure 2-9: Vivado IP Integrator Diagram and AXI Interface Level Connections

An interface is a grouping of signals that share a common function. An AXI4 master interface, for example, contains a large number of individual signals which are required to be wired correctly to make a connection.

If each signal in an interface is presented separately, the IP symbol is visually very complex and requires more effort to connect. By grouping these signals into a single AXI interface, a single Tcl command or GUI connection can be made using a higher level of abstraction.

The Vivado IP integrator contains design rule checks (DRCs) and automation facilities that are aware of each specific AXI interfaces to help ensure that the required signals are connected and configured properly. IP integrator offers design assistance as you develop your design.

For more information about the Vivado IP integrator, see *Vivado Design Suite User Guide: Designing IP Subsystems Using IP Integrator* (UG994) [Ref 38].

Using AXI IP in System Generator for DSP

System Generator for DSP[®] is a design tool that lets you use of the MathWorks model-based Simulink[®] product design environment for FPGA design. Designs are captured in a DSP-friendly Simulink modeling environment using an optimized Xilinx-specific blockset.

System Generator supports the following:

- AXI4-Lite and AXI4-Stream interfaces which move data in and out of the DSP design created with System Generator. By using AXI4-Lite and AXI4-Stream for data transfer, it is easier to integrate a DSP design into a broader system using the Vivado Design Suite.
- Libraries of IP that users connect together using their AXI4-Stream interfaces. The DSP designs created using System Generator can be created using AXI4-Stream based DSP blocks.

For more information on using this tool to create AXI-based IP, see *Vivado Design Suite User Guide: Model-Based DSP Design using System Generator* (UG897) [Ref 31]. Also, see the *System Generator for DSP website* [Ref 49].

The following figure shows how to specify an AXI4-Lite interface on a Gateway In block.

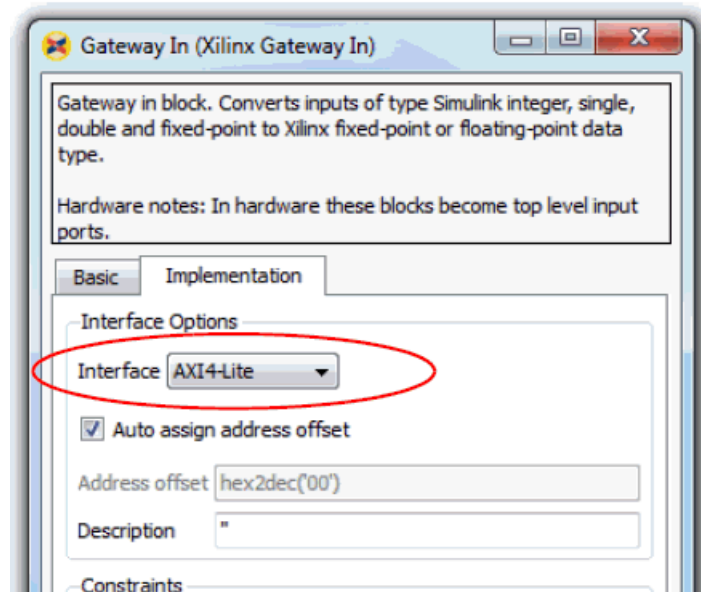

Figure 2-10: Specifying an AXI4-Lite Interface in System Generator for DSP

Port Name Truncation

System Generator shortens the AXI4-Stream signal names to improve readability on the block; this is cosmetic and the complete AXI4-Stream name is used in the netlist.

The name truncation is turned on by default; uncheck the **Display shortened port names** option in the block parameter dialog box to see the full name.

Port Groupings

System Generator groups together and color-codes blocks of AXI4-Stream channel signals. In the example illustrated in the following figure, the top-most input port, `data_tready`, and the top two output ports, `data_tvalid` and `data_tdata` belong in the same AXI4-Stream channel, as well as `phase_tready`, `phase_tvalid`, and `phase_tdata`.

System Generator gives signals that are not part of any AXI4-Stream channels the same background color as the block; the `aresetn` signal, shown in the following figure, is an example.

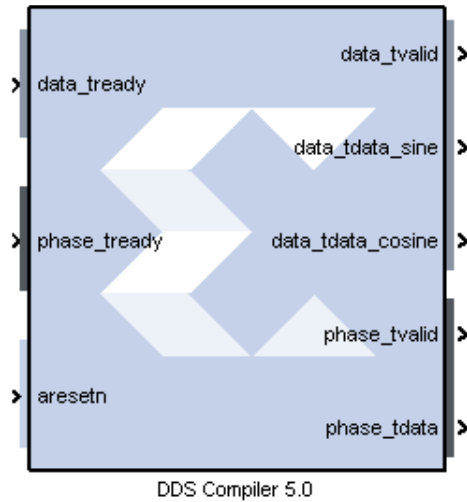

Figure 2-11: Block Signal Groupings

Breaking Out Multichannel TDATA

The `tdata` signal in an AXI4-Stream can contain multiple channels of data. In System Generator, the individual channels for `tdata` are broken out; for example, in the complex multiplier shown in the following figure, the `tdata` for the `dout` port contains both the imaginary and the real number components.

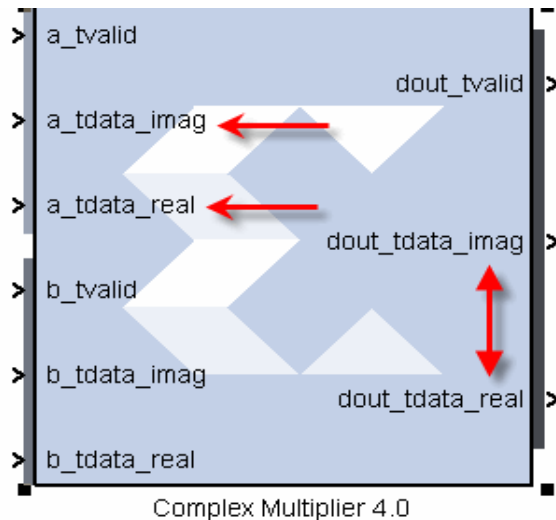

Figure 2-12: Multi-Channel TDATA

Note: Breaking out of multichannel `tdata` does not add additional logic to the design. The data is correctly byte-aligned also.

Adding AXI Interfaces Using High Level Synthesis

The Vivado High Level Synthesis (HLS) tool transforms a C, C++, SystemC, or OpenCL design specification into a Register Transfer Level (RTL) implementation that you synthesize in turn into an FPGA device.

Vivado HLS supports adding AXI interfaces you can transfer information into and out of a design synthesized from the C, C++, SystemC, or OpenCL description. This feature combines the ability to implement algorithms using a higher level of abstraction with the plug-and-play benefits of the AXI protocol to integrate that design into a system with ease.

You can integrate Vivado HLS designs with AXI interfaces through Vivado IP integrator, or instantiate directly into RTL designs.

C-based designs perform I/O operations in zero time, through formal function arguments. In an RTL design, you perform I/O operations through a port in the design interface, that typically operate using a specific I/O protocol.

Vivado HLS supports the automatic synthesis of function arguments into the following AXI4 interfaces:

- AXI4-Stream (`axis`)
- AXI4-Lite slave (`s_axilite`)
- AXI4 master (`m_axi`)

The following subsections provide a brief description of the Vivado HLS AXI functionality. For more information, see the Vivado *Design Suite User Guide: High-Level Synthesis* (UG902) [Ref 32].

HLS AXI4-Stream Interface

You can apply an AXI4-Stream interface (`axis` mode) to any input argument and any array or pointer output argument. Because the AXI4-Stream interface transfers data in a sequential streaming manner it cannot be used with arguments which are both read and written.

You can use an AXI4-Stream in your design: with or without side-channels.

- **With side-channels:** Using AXI4-Stream interface with side-channels provides additional functionality, allowing the optional side-channels which are part of the AXI4-Stream standard, to be used directly in the C code.
- **Without side-channels:** Use the AXI4-Stream when the data type does not contain any AXI4 side-channel elements.

The following example shows a design where the data type is a standard C `int` type. In this example, both interfaces are implemented using AXI4-Stream:

```
void example(int A[50], int B[50]) {
//Set the HLS native interface types
#pragma HLS INTERFACE axis port=A
#pragma HLS INTERFACE axis port=B

    int i;

    for(i = 0; i < 50; i++){
        B[i] = A[i] + 5;
    }
}
```

After you synthesize the code in the previous example, HLS implements both arguments with a data port and the standard AXI4-Stream `TVALID` and `TREADY` protocol ports, as shown in the following figure.

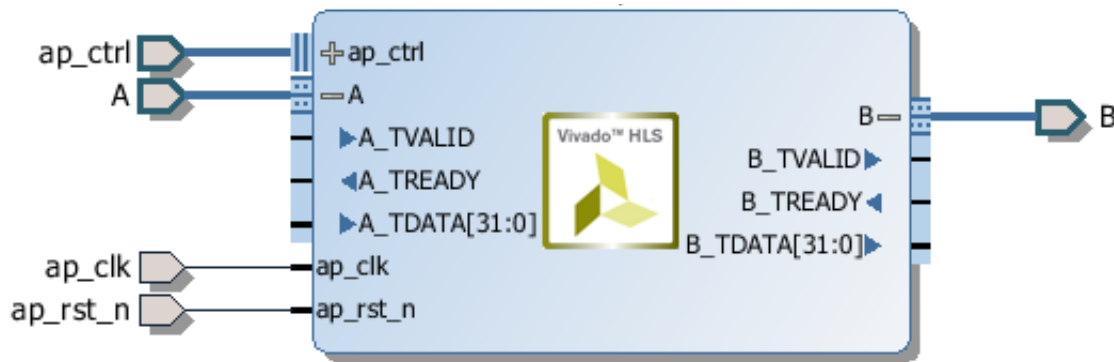

Figure 2-13: HLS AXI4-Stream Interfaces without Side-Channels

HLS AXI4-Lite Interface

An AXI4-Lite slave interface is typically used to allow a design to be controlled by some form of CPU or microcontroller. The Vivado HLS features of the AXI4-Lite slave interface, (`s_axilite` mode) are:

- Grouping multiple ports into the same AXI4-Lite slave interface.
- Outputting C function and header files for use with the code running on a processor when you export the design to the Vivado IP catalog.

The following code example shows an implementation of multiple arguments, including the function return, as AXI4-Lite slave interfaces in `bundle=BUS_A`. Because each interface uses the same name for the bundle option, the HLS tool groups each of the ports into the same AXI4-Lite interface:

```
void example(char *a, char *b, char *c)
{
#pragma HLS INTERFACE s_axilite port=return bundle=BUS_A
```

```
#pragma HLS INTERFACE s_axilite port=a      bundle=BUS_A
#pragma HLS INTERFACE s_axilite port=b      bundle=BUS_A
#pragma HLS INTERFACE s_axilite port=c      bundle=BUS_A

    *c += *a + *b;
}
```

After synthesizing the previous example code, HLS implements the ports, with the AXI4-Lite slave port expanded, as shown in the following figure. The interrupt port is created by including the function return in the AXI4-Lite slave interface. The block-level protocol port, `ap_done`, drives the interrupt, which indicates when the function has completed operation.

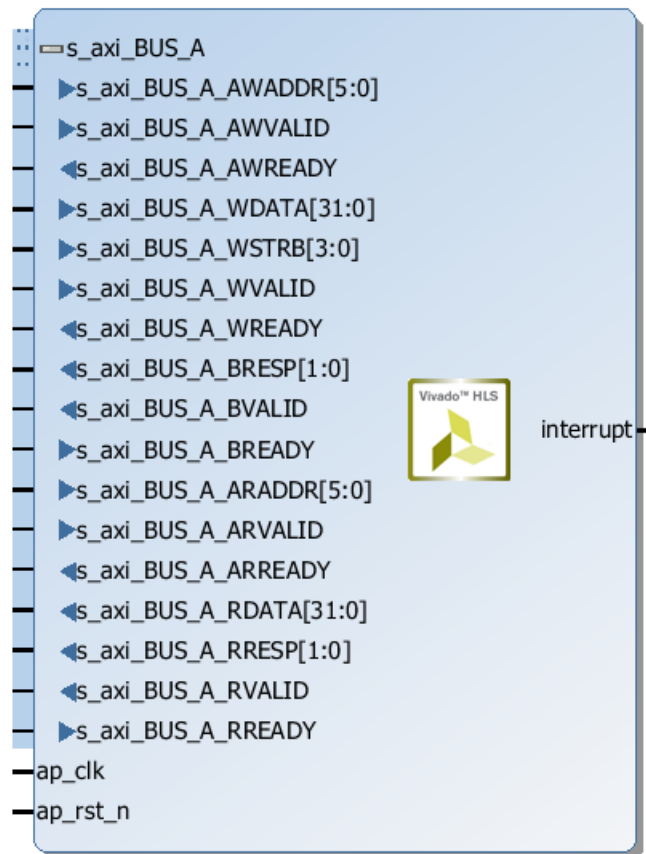

Figure 2-14: HLS AXI4-Lite Slave Interfaces with Grouped RTL Ports

HLS AXI4 Master Interface

You can implement the HLS AXI4 master interface (`m_axi` mode) on any array or pointer/reference arguments. The interface is used two modes: individual data transfers, burst-mode data transfers using the C `memcpy` function.

Individual Data Transfers

Individual data transfers are those with the characteristics shown in the following code examples, where a data is read or written to the top-level function argument. The following code snippets show examples:

Example 1:

```
void bus (int *d) {  
    static int acc = 0;  
  
    acc += *d;  
    *d = acc;  
}
```

Example 2:

```
void bus (int *d) {  
    static int acc = 0;  
    int i;  
  
    for (i=0;i<4;i++) {  
        acc += d[i];  
        d[i] = acc;  
    }  
}
```

In both cases, the data transfers over the AXI4 master interface as simple read or write operations: one address, one data values at a time.

Burst-Mode Transfers

Burst-mode transfers data using a single base address, which is followed by multiple sequential data samples, and is capable of higher data throughput. Burst-mode is possible only when you use the C `memcpy` function to read data into, or data out of, the top-level function for synthesis.

The following example shows a copy of a burst-mode AXI4 master interface transfer. The top-level function, argument *a*, is specified as the AXI4 master interface:

```
void example(volatile int *a){

    #pragma HLS INTERFACE m_axi depth=50 port=a
    #pragma HLS INTERFACE s_axilite port=return bundle=AXILiteS

    //Port a is assigned to an AXI4-master interface

    int i;
    int buff[50];

    // memcpy creates a burst access to memory
    memcpy(buff, (const int*)a, 50*sizeof(int));

    for(i=0; i < 50; i++){
        buff[i] = buff[i] + 100;
    }

    memcpy((int *)a, buff, 50*sizeof(int));
}
```

When you synthesize a design with the previous example, it results in an interface as shown in the following figure (the AXI interfaces are shown collapsed):



Figure 2-15: HLS AXI Master Interface

Samples of Vivado AXI IP and Xilinx Processors

Overview

Xilinx offers a suite of AXI Infrastructure IP that serve as system building blocks. These IP provide the ability to move data, operate on data, and measure, test, and debug AXI transactions. For a more complete list of AXI IP, see the Xilinx® *IP Center website* [Ref 3].

The following IP descriptions are samples of the common, available AXI IP developed by Xilinx, and a brief description of the Xilinx processors: Zynq® MPSoC UltraScale+™ processor, the Zynq-7000 All Programmable SoC processor, and the MicroBlaze™ processor, which include AXI IP.

AXI Infrastructure IP Cores

The AXI Infrastructure is a collection of the following IP cores:

- **AXI Crossbar:** Connects one or more similar AXI memory-mapped masters to one or more similar memory-mapped slaves.
- **AXI Data Width Converter:** Connects one AXI memory-mapped master to one AXI memory-mapped slave having a wider or narrower data path.
- **AXI Clock Converter:** Connects one AXI memory-mapped master to one AXI memory-mapped slave operating in a different clock domain.
- **AXI Protocol Converter:** Connects one AXI4, AXI3 or AXI4-Lite master to one AXI slave of a different AXI memory-mapped protocol.
- **AXI Data FIFO:** Connects one AXI memory-mapped master to one AXI memory-mapped slave through a set of FIFO buffers.
- **AXI Register Slice:** Connects one AXI memory-mapped master to one AXI memory-mapped slave through a set of pipeline registers, typically to break a critical timing path.
- **AXI MMU:** Provides address range decoding services for AXI Interconnect.

AXI Interconnect is available as a standalone IP in the Xilinx IP catalog for use in an RTL design. The standalone AXI Interconnect has a reduced feature set, mainly suitable for connecting multiple AXI4 masters to a single AXI4 slave. See the *LogiCORE IP AXI Interconnect IP Product Guide (PG059)* [Ref 5] for more information.

The IP integrator provides the user a choice to select between the AXI Interconnect and the new AXI SmartConnect if the endpoints being connected are AXI4 memory-mapped endpoints.

The IP integrator tool provides enhanced features, greater ease of use, and automation services. See the following documents for more information:

- *Vivado Design Suite User Guide: Designing IP Subsystems Using IP Integrator (UG994)* [Ref 38]
- *Vivado Design Suite Tutorial: Designing IP Subsystems Using IP Integrator (UG995)* [Ref 39]

Xilinx AXI SmartConnect and AXI Interconnect IP

The Xilinx LogiCORE IP AXI Interconnect and LogiCORE IP AXI SmartConnect cores both connect one or more AXI memory-mapped master devices to one or more memory-mapped slave devices; however, the SmartConnect is more tightly integrated into the Vivado design environment to automatically configure and adapt to connected AXI master and slave IP with minimal user intervention. The AXI Interconnect can be used in all memory-mapped designs. There are certain cases for high bandwidth application where using a SmartConnect provides better optimization. The AXI SmartConnect IP delivers the maximum system throughput at low latency by synthesizing a low area custom interconnect that is optimized for important interfaces.

The AXI Interconnect core IP (`axi_interconnect`) connects one or more AXI memory-mapped master devices to one or more memory-mapped slave devices.

The AXI interfaces conform to the AMBA[®] AXI4 specification from ARM[®], including the AXI4-Lite control register interface subset.



IMPORTANT: *The AXI Interconnect and the AXI SmartConnect core IP are intended for memory-mapped transfers only; AXI4-Stream transfers are not applicable, but instead can use the AXI4-Stream Interconnect core IP (`axis_interconnect`). IP with AXI4-Stream interfaces are generally connected to one another, to DMA IP, or to the AXI4-Stream Interconnect IP.*



RECOMMENDED: *For new medium to high performance designs, the AXI SmartConnect IP is recommended as it offers better upward scaling in area and timing. For low performance (AXI4-Lite) or small to medium complexity designs, AXI Interconnect may be more area efficient.*

The following section is extracted from the *LogiCORE IP AXI Interconnect IP Product Guide* (PG059) [Ref 12]. See the [AXI SmartConnect IP](#) section for more in that IP.

AXI Interconnect Core Features

The AXI Interconnect IP contains the following features:

- AXI protocol compliant (AXI3, AXI4, and AXI4-Lite), which includes:
 - Burst lengths up to 256 for incremental (`INCR`) bursts
 - Converts AXI4 bursts >16 beats when targeting AXI3 slave devices by splitting transactions.
 - Propagates `USER` signals on each channel, if any; independent `USER` signal width per channel (optional)
 - Propagates Quality of Service (QoS) signals, if any; not used by the AXI Interconnect core (optional)
- Interface data widths:
 - AXI4: 32, 64, 128, 256, 512, or 1024 bits.
 - AXI4-Lite: 32 bits and 64 bits
- Address width: Up to 64-bits
- ID width: Up to 32 bits
- Support for Read-only and Write-only masters and slaves, resulting in reduced resource utilization.

Note: When used in a standalone mode, the AXI Interconnect core connects multiple masters to one slave, which is typically a memory controller.

- Built-in data-width conversion:
 - Each master and slave connection can independently use data widths of 32, 64, 128, 256, 512, or 1024 bits wide:
 - The internal crossbar can be configured to have a native data-width of 32, 64, 128, 256, 512, or 1024 bits.
 - Data-width conversion is performed for each master and slave connection that does not match the crossbar native data-width.
 - When converting to a wider interface (upsizing), data is packed (merged) optionally, when permitted by address channel control signals (`CACHE` modifiable bit is asserted).
 - When converting to a narrower interface (downsizing), burst transactions can be split into multiple transactions if the maximum burst length would otherwise be exceeded.
- Built-in clock-rate conversion:
 - Each master and slave connection can use independent clock rates.

- Synchronous integer-ratio (N:1 and 1:N) conversion to the internal crossbar native clock-rate.
- Asynchronous clock conversion (uses more storage and incurs more latency than synchronous conversion).
- The AXI Interconnect core exports reset signals re-synchronized to the clock input associated with each SI and MI slot.
- Built-in AXI4-Lite protocol conversion:
 - The AXI Interconnect core can connect to any mixture of AXI4 and AXI4-Lite masters and slaves.
 - The AXI Interconnect core saves transaction IDs and restores them during response transfers, when connected to an AXI4-Lite slave.
 - AXI4-Lite slaves do not need to sample or store IDs.
 - The AXI Interconnect core detects illegal AXI4-Lite transactions from AXI4 masters, such as any transaction that accesses more than one word.

It generates a protocol-compliant error response to the master, and does not propagate the illegal transaction to the AXI4-Lite slave.

- Built-in AXI3 protocol conversion:
 - The AXI Interconnect core splits burst transactions of more than 16 beats from AXI4 masters into multiple transactions of no more than 16 beats when connected to an AXI3 slave.
- Optional register-slice pipelining:
 - Available on each AXI channel connecting to each master and each slave.
 - Facilitates timing closure by trading-off frequency versus latency.
 - One latency cycle per register-slice, with no loss in data throughput under all AXI handshaking conditions.
- Optional data path FIFO buffering:
 - Available on write and read data paths connecting to each master and each slave.
 - 32-deep LUT-RAM based.
 - 512-deep block RAM based.
 - Option to delay assertion of:
 - `AWVALID` until the complete burst is stored in the W-channel FIFO
 - `ARVALID` until the R-channel FIFO has enough vacancy to store the entire burst length
- Selectable Interconnect Architecture:
 - Shared-Address, Multiple-Data (SAMD) crossbar (Performance Optimized):
 - Parallel crossbar pathways for write data and read data channels.

When more than one write or read data source has data to send to different destinations, data transfers can occur independently and concurrently, provided AXI ordering rules are met.

- Shared Access Shared Data (SASD) mode (Area optimized):
 - Shared write data, shared read data, and single shared address pathways.
 - Issues one outstanding transaction at a time.
 - Minimizes resource utilization.
- Supports multiple outstanding transactions:
 - Supports masters with multiple reordering depth (ID threads).
 - Supports up to 16-bit wide ID signals (system-wide).
 - Supports write response re-ordering, read data re-ordering, and read data interleaving.
 - Configurable write and read transaction acceptance limits for each connected master.
 - Configurable write and read transaction issuing limits for each connected slave.
- “Single-Slave per ID” method of cyclic dependency (deadlock) avoidance:
 - For each ID thread issued by a connected master, the master can have outstanding transactions to only one slave for writes and one slave for reads, at any time.
- Fixed priority and round-robin arbitration:
 - 16 configurable levels of static priority.
 - Round-robin arbitration is used among all connected masters configured with the lowest priority setting (priority 0), when no higher priority master is requesting.
 - Any SI slot that has reached its acceptance limit, or is targeting an MI slot that has reached its issuing limit, or is trying to access an MI slot in a manner that risks deadlock, is temporarily disqualified from arbitration, so that other SI slots can be granted arbitration.
- Supports TrustZone security for each connected slave as a whole:
 - If configured as a secure slave, only secure AXI accesses are permitted
 - Any non-secure accesses are blocked and the AXI Interconnect core returns a DECERR response to the master
- Support for read-only and write-only masters and slaves, resulting in reduced resource utilization.

AXI Interconnect Core Limitations

These limitations apply to the AXI Interconnect core and all applicable infrastructure cores:

- The AXI Interconnect core does not support discontinued AXI3 features:
 - Atomic locked transactions. This feature was retracted by AXI4 protocol. A locked transaction is changed to a non-locked transaction and propagated by the MI.
 - Write interleaving. This feature was retracted by AXI4 protocol. AXI3 master devices must be configured as if connected to a slave with a write interleaving depth of one.
- AXI4 Quality of Service (QoS) signals do not influence arbitration priority in AXI Crossbar. QoS signals are propagated from SI to MI.
- AXI Interconnect and the Vivado IDE do not support the use of AXI `AWREGION` and `ARREGION` signals.
- Interconnect cores do not support low-power mode or propagate the AXI C-channel signals.
- AXI Interconnect cores do not time out if the destination of any AXI channel transfer stalls indefinitely. All connected AXI slaves must respond to all received transactions, as required by AXI protocol.
- AXI Interconnect (including AXI Crossbar and AXI MMU cores) provides no address remapping.
- AXI Interconnect sub-cores do not include conversion or bridging to non-AXI protocols, such as APB.
- AXI Interconnect cores do not have clock-enable (`ac1ken`) inputs. Consequently, the use of `ac1ken` is not supported among memory-mapped AXI interfaces in Xilinx systems.

Note: The `ac1ken` signal is supported for Xilinx AXI4-Stream interfaces.

The following subsection describes the use models for the AXI Interconnect core.

AXI Interconnect Core Use Models

The AXI Interconnect IP core connects one or more AXI memory-mapped master devices to one or more memory-mapped slave devices. The following subsections describe the possible use cases:

- [Conversion Only](#)
- [N-to-1 Interconnect](#)
- [1-to-N Interconnect](#)
- [N-to-M Interconnect \(Sparse Crossbar Mode\)](#)

Conversion Only

The AXI Interconnect core can perform various conversion and pipelining functions when connecting one master device to one slave device. These are:

- Data width conversion
- Clock rate conversion
- AXI4-Lite slave adaptation
- AXI-3 slave adaptation
- Pipelining, such as a register slice or data channel FIFO

In these cases, the AXI Interconnect core contains no arbitration, decoding, or routing logic. There could be incurred latency, depending on the conversion being performed.

The following figure shows the one-to-one or conversion use case.

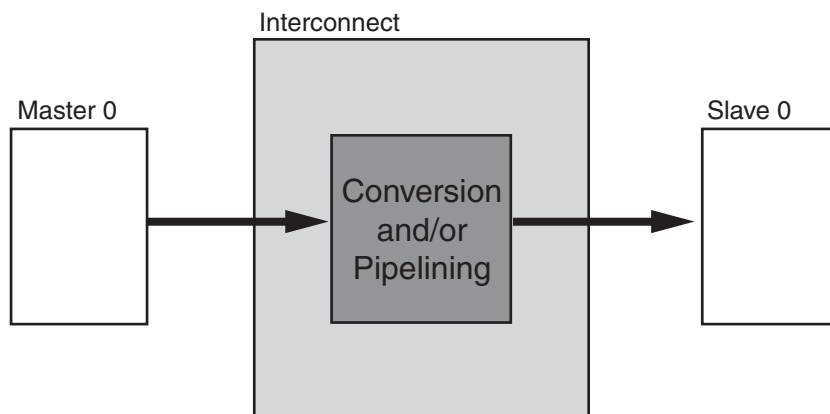

Figure 3-1: 1-to-1 Conversion AXI Interconnect Use Case

N-to-1 Interconnect

A common degenerate configuration of AXI Interconnect core is when multiple master devices arbitrate for access to a single slave device, typically a memory controller. In these cases, address decoding logic might be unnecessary and omitted from the AXI Interconnect core (unless address range validation is needed).

Conversion functions, such as data width and clock rate conversion, can also be performed in this configuration. The following figure shows the N-to-1 AXI interconnection use case.

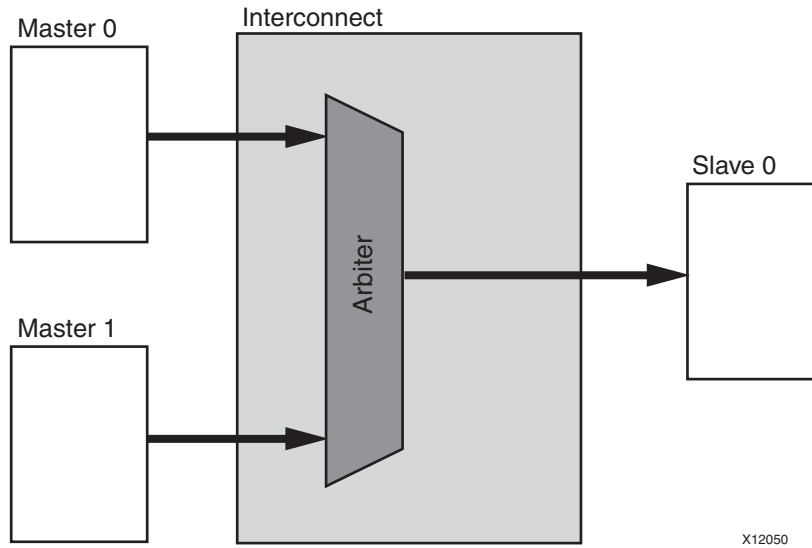

Figure 3-2: N-to-1 AXI Interconnect

1-to-N Interconnect

Another degenerative configuration of the AXI Interconnect core is when a single master device, typically a processor, accesses multiple memory-mapped slave peripherals. In these cases, arbitration (in the address and write data paths) is not performed. The following figure shows the 1 to N Interconnect use case.

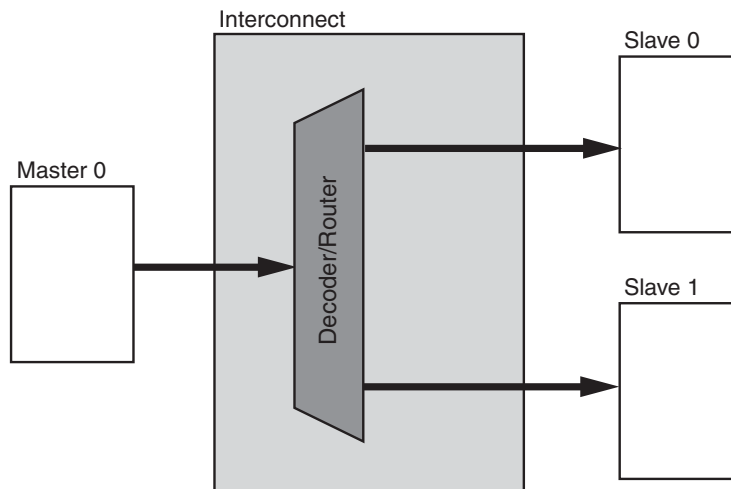

Figure 3-3: 1-to-N AXI Interconnect Use Case

N-to-M Interconnect (Sparse Crossbar Mode)

The N-to-M use case of the AXI Interconnect features a Shared-Address Multiple-Data (SAMM) topology, consisting of sparse data crossbar connectivity, with single-threaded write and read address arbitration, as shown in Figure 3-4.

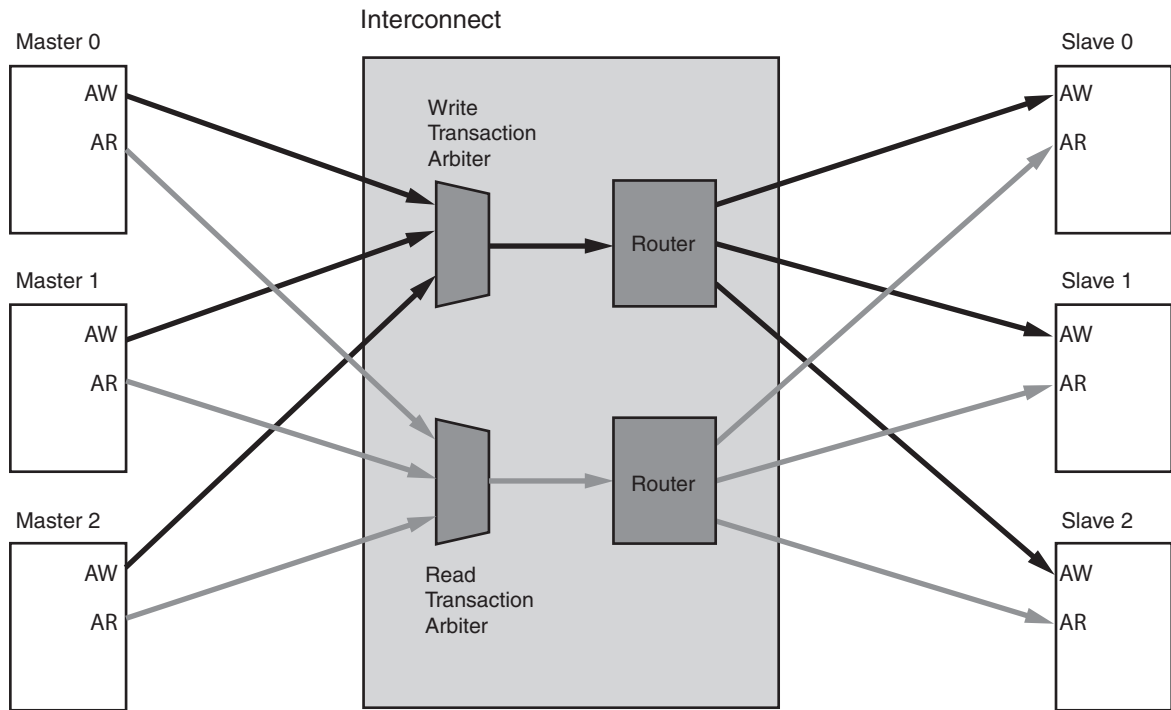

Figure 3-4: Shared Write and Read Address Arbitrations

The following figure shows the sparse crossbar write and read data pathways.

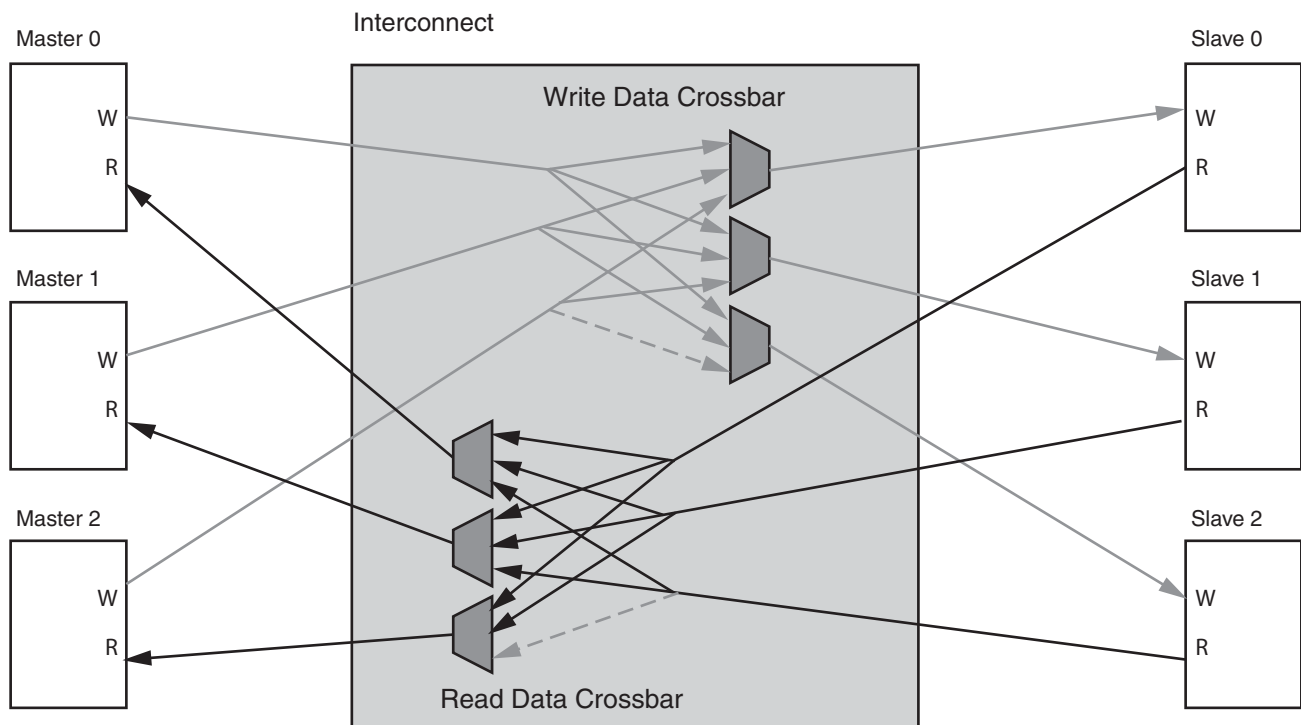

Figure 3-5: Sparse Crossbar Write and Read Pathways

Parallel write and read data pathways connect each SI slot (attached to AXI masters on the left) to all the MI slots (attached to AXI slaves on the right) that it can access, according to the configured sparse connectivity map.

When more than one source has data to send to different destinations, data transfers can occur independently and concurrently, provided AXI ordering rules are met.

The write address channels among all SI slots (if > 1) feed into a central address arbiter, which grants access to one SI slot at a time, as is also the case for the read address channels. The winner of each arbitration cycle transfers its address information to the targeted MI slot and pushes an entry into the appropriate command queue(s) that enable various data pathways to route data to the proper destination while enforcing AXI ordering rules.

Cascading AXI Interconnect Cores Together

You can connect the slave interface of one AXI Interconnect core module to the master interface of another AXI Interconnect core with no intervening logic. Cascading multiple AXI Interconnects allow systems to be partitioned and potentially better optimized.

AXI SmartConnect IP

The following information is extracted from the *LogicCORE IP AXI SmartConnect Product Guide* (PG247) [Ref 23].

Feature Summary

- Up to 16 Slave Interfaces (SI) and up to 16 Master Interfaces (MI) per instance.
- Instances of SmartConnect can be cascaded to interconnect a larger number of masters/slaves or for organizing the interconnect topology.
- AXI Protocol compliant. Each SI and MI of SmartConnect can be connected to a master or slave IP interface of type AXI3, AXI4 or AXI4-Lite.
- Transactions between interfaces of different protocol types are automatically converted by SmartConnect.
- Burst transactions are automatically split, as needed, to remain AXI compliant.
- Interface Data Widths (bits):
 - AXI4 and AXI3: 32,64,128,256, 512 or 1024.
 - AXI4-Lite: 32 or 64-bit.
- Transactions between interfaces of different data widths are automatically converted by SmartConnect.
- Supports multiple clock domains (the IP provides one clock pin per domain).
- Transactions between interfaces in different clock domains are automatically converted by SmartConnect.

- Address width: Up to 64 bits:
- SmartConnect decodes up to 256 total address range segments.
- User defined signals up to 512 bits wide per channel.
 - User signals on any AXI channel are propagated regardless of internal transaction conversions.
- ID width: Up to 32 bits
 - Automatic re-mapping/compression of wide input ID signals.
- Support for Read-only and Write-only masters and slaves, resulting in reduced resource utilization.
- Supports multiple outstanding transactions:
 - Supports connected masters with multiple reordering depth (ID threads).
 - Supports write response re-ordering, Read data re-ordering, and Read Data interleaving.
 - Multi-threaded traffic (propagation of ID signals) is supported regardless of internal transaction conversions, including data width conversion and transaction splitting.
 - Optional single ordering mode (per SI and MI). Stores ID values internally instead of propagating to the slave, resulting in reduced resource utilization.
- “Single-Slave per ID” method of cyclic dependency (deadlock) avoidance.
 - For each ID thread issued by a connected master, the SmartConnect allows one or more outstanding transactions to only one slave device for Writes and one slave device for Reads, at a time.
 - Multiple parallel pathways along all AXI channels when connected to multiple masters and multiple slaves:
 - Each AXI channel has independent destination-side arbitration. Transfers from two or more source endpoints to separate destination endpoints can occur concurrently, for any AXI channel.
 - Round-robin arbitration for each of the AW, AR, R and B channels. (W-channel transfers follow the same order as AW-channel arbitration, per AXI protocol rules.)
- Supports back-to-back transfers (100% duty cycle) on any AXI channel:
 - Single data-beat transactions can traverse the SmartConnect at the same bandwidth as multi-beat bursts.
- Supports TrustZone security for each connected slave:
 - If configured as a secure address segment, only secure AXI accesses are permitted according to the AXI `arprot` or `awprot` signal.
 - Any non-secure accesses are blocked and the AXI SmartConnect core returns a `decerr` response to the connected master.

- Internally resynchronized reset:
 - One `aresetn` input per IP.

AXI SmartConnect Core Limitations

These limitations apply to the AXI SmartConnect core:

- SmartConnect unconditionally packs all multi-beat bursts to fill the interface data-width.
- SmartConnect SI interfaces accept “narrow” bursts, in which the `arsize` or `awsize` signal indicates data units which are smaller than the interface data-width. But such bursts are always propagated through the SmartConnect and its MI interfaces fully packed. The “modifiable bit” of the AXI `arcache` or `awcache` signal does not prevent packing.
- SmartConnect converts all WRAP type bursts into INCR type. SmartConnect SI interfaces accept all protocol-compliant WRAP bursts, beginning at any target address. But such bursts are always converted to a single INCR burst beginning at the “wrap address”. This may increase response latency of unaligned read wrap bursts.
- SmartConnect does not support FIXED type bursts. Any FIXED burst transaction received at the SmartConnect SI is blocked and a DECERR response is returned to the master.
- SmartConnect does not propagate original ID values from endpoint masters. IDs received at an SI interface are re-mapped to a smaller (or equal) number of bits for more resource-efficient management of multi-threaded traffic.
- SmartConnect appends ID bits to differentiate among multiple masters, when propagating transactions to the MI. Values of master identification bits are assigned by IP Integrator and cannot be controlled or predicted by the user.
- The AXI SmartConnect core does not support discontinued AXI3 features:
 - **Atomic locked transactions.** This feature was retracted by AXI4 protocol. A locked transaction is changed to a non-locked transaction and propagated by the MI.
 - **Write interleaving.** This feature was retracted by AXI4 protocol. AXI3 master devices must be configured as if connected to a slave with a Write interleaving depth of one.
- All arbitration on all AXI channels is round-robin. SmartConnect does not support fixed priority arbitration.
- AXI4 Quality of Service (`arqos` and `awqos`) signals do not influence arbitration priority. QoS signals are propagated from SI to MI.
- SmartConnect neither propagates nor generates the AXI4 `arregion` or `awregion` signal.

- SmartConnect does not support independent reset domains. If any master or slave device connected to SmartConnect is reset, then all connected devices must be reset concurrently.
- AXI SmartConnect core does not support low-power mode or propagate the AXI C channel signals.
- AXI SmartConnect cores does not time out if the destination of any AXI channel transfer stalls indefinitely. All connected AXI slaves must respond to all received transactions, as required by AXI protocol.
- AXI SmartConnect provides no address remapping. AXI SmartConnect core does not include conversion or bridging to non-AXI protocols, such as APB.

AXI4-Stream Interconnect Core IP

The AXI4-Stream Interconnect core IP (`axis_interconnect`) connects one or more AXI4-Stream master devices to one or more stream slave devices. The AXI interfaces conform to the ARM®AMBA® *AXI4-Stream Product Guide* (PG035) [Ref 9].

Note: The AXI4-Stream Interconnect core IP is intended for AXI4-Stream transfers only; AXI memory-mapped transfers are not applicable.

The AXI4-Stream Interconnect IP is available in IP integrator and as standalone IP:

- The *Infrastructure* version for IP integrator has enhanced features, greater ease of use, and automation services. See the *AXI4-Stream Infrastructure IP Suite: Product Guide for Vivado Design Suite* (PG035) [Ref 9] for more information.
- AXI4-Stream Interconnect is also available standalone directly from the IP catalog for use in an RTL design. See the *AXI4-Stream Interconnect IP Product Guide* (PG085) [Ref 14] for more information. The following information is extracted from the AXI-4 Stream Product Guide.

AXI4-Stream Interconnect Core Features

The AXI4-Stream Interconnect IP contains the following features:

- AXI4-Stream compliant:
 - Supports all AXI4-Stream defined signals: TVALID, TREADY, TDATA, TSTRB, TKEEP, TLAST, TID, TDEST, and TUSER1
 - TDATA, TSTRB, TKEEP, TLAST, TID, TDEST, and TUSER are optional
 - Programmable TDATA, TID, TDEST, and TUSER widths (TSTRB and TKEEP width is TDATA width/8).
 - Per port ACLK/ARESETn inputs (supports clock domain crossing).
 - Per port ACLKEN inputs (optional).

- Core switch:
 - 1-16 masters.
 - 1-16 slaves.
 - Full slave-side arbitrated crossbar switch.
 - Slave input to master output routing based on `TDEST` value decoding and comparison against base and high value range settings.
 - Round-Robin and Priority arbitration.
 - Arbitration suppress capability to prevent head-of-line blocking.
 - Native switch data width 8, 16, 24, 32, 48, ... 4096 bits (any byte width up to 512 bytes).
 - Arbitration tuning parameters to arbitrate on `TLAST` boundaries, after a set number of transfers, and/or after a certain number of idle clock cycles.
 - Optional pipeline stages after internal `TDEST` decoder and arbiter functional blocks.
 - Programmable connectivity map to specify full or sparse crossbar connectivity.
- Built-in data width conversion:
 - Each master and slave connection can independently use data widths of 8, 16, 24, 32, 48, ... 4096 bits (any byte width up to 512 bytes).
- Built-in clock-rate conversion:
 - Each master and slave connection can use independent clock rates.
 - Synchronous integer-ratio (N:1 and 1:N) conversion to the internal crossbar native clock rate.
 - Asynchronous clock conversion (uses more storage and incurs more latency than synchronous conversion).
- Optional register-slice pipelining:
 - Available on each AXI4-Stream channel connecting to each master and slave device.
 - Facilitates timing closure by trading-off frequency versus latency.
 - One latency cycle per register-slice, with no loss in data throughput in the register slice under all AXI4-Stream handshake conditions.
- Optional data path FIFO buffering:
 - Available on data paths connecting to each master and each slave.
 - 16, 32, 64, 128, through 32768 deep (16-deep and 32-deep are LUT-RAM based; otherwise are block RAM based).
 - Normal and Packet FIFO modes (Packet FIFO mode is also known as store-and-forward in which a packet is stored and only released downstream after a `TLAST` packet boundary is detected.)

- FIFO data count outputs to report FIFO occupancy.
- Additional error flags to detect conditions such as TDEST decode error, sparse TKEEP removal, and packer error.

AXI4-Stream Interconnect Core Diagram

The following figure illustrates a top-level AXI4-Stream Interconnect architecture.

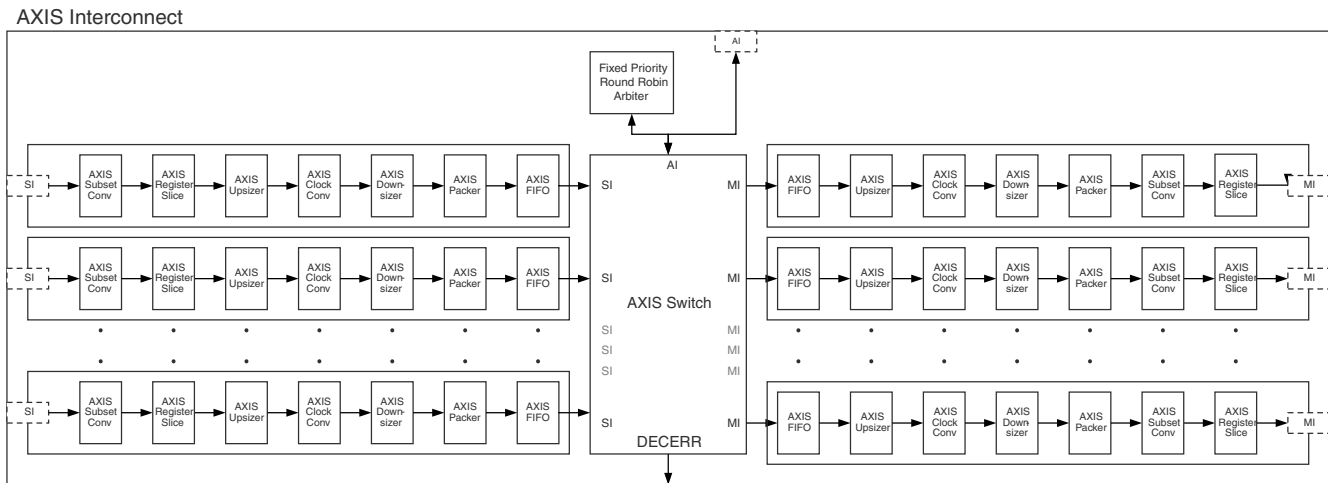

Figure 3-6: Top-Level AXI4-Stream Interconnect Architecture

The AXI4-Stream Interconnect core consists of the SI, the MI, and the functional units that include the AXI channel pathways between them.

- The SI accepts transaction requests from connected master devices.
- The MI issues transactions to slave devices.
- At the center is the switch that arbitrates and routes traffic between the various devices connected to the SI and MI.

The AXI4-Stream Interconnect core also includes other functional units located between the switch and each of the SI and MI interfaces that optionally perform various conversion and storage functions. The switch effectively splits the AXI4-Stream Interconnect core down the middle between the SI-related functional units (*SI hemisphere*) and the MI-related units (*MI hemisphere*). This architecture is similar to that of the AXI Interconnect.

AXI4-Stream Interconnect Core Use Models

The AXI4-Stream Interconnect IP core connects one or more AXI4-Stream master devices to one or more AXI4-Stream slave devices. The following subsections describe the possible use cases:

- Streaming data routing and switching
- Stream multiplexing and de-multiplexing

Streaming Data Routing and Switching (Crossbar Mode)

The AXI4-Stream Interconnect can implement a full $N \times M$ crossbar switch as shown in the following figure. It supports slave side arbitration capable of parallel data traffic between N masters and M slaves. Decoders and arbiters serve to route transactions between masters and slaves.

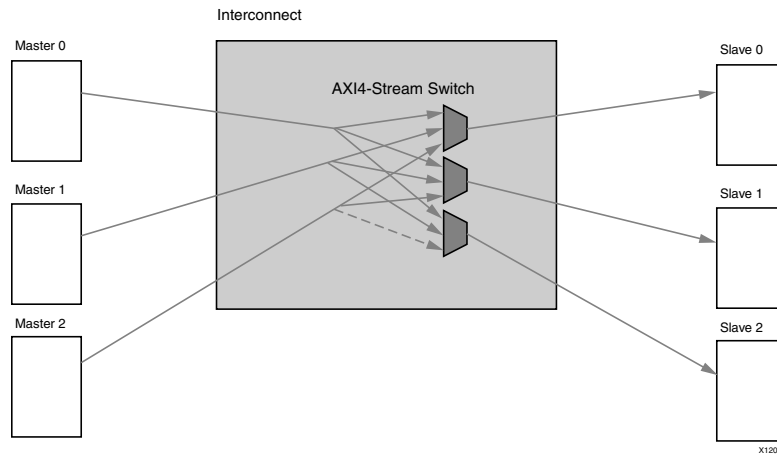

Figure 3-7: $N \times M$ Crossbar Switch (Crossbar Mode)

Stream Multiplexing and De-multiplexing

You can configure the AXI4-Stream Interconnect in an $N \times 1$ configuration to multiplex streams together and then configured as $1 \times M$ to de-multiplex streams. Use multiplexing and de-multiplexing to create multi-channel streams where a smaller number of wires can carry shared traffic from multiple masters or slaves.

For example, in the following figure, AXI4-Stream interconnects are used with the AXI virtual FIFO controller to multiplex and demultiplex multiple streams from multiple endpoint masters and slaves together. For more information, see the *LogicCORE IP AXI Virtual FIFO Controller Product Guide* (PG038) [Ref 11].

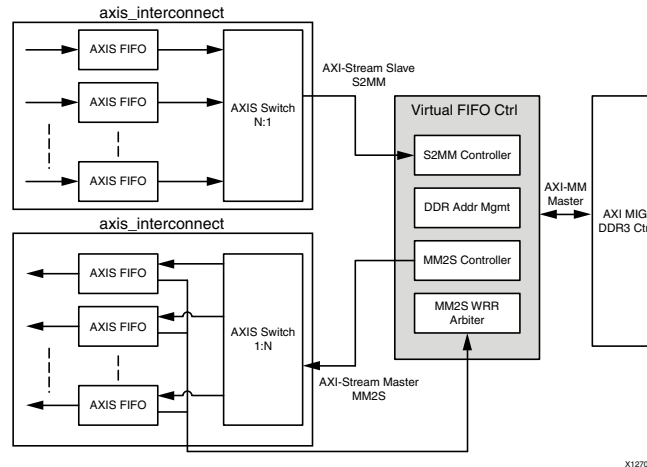

Figure 3-8: IAXI4-Stream Interconnects with AXI Virtual FIFO Controller

AXI Virtual FIFO Controller

The Xilinx LogiCORE™ IP AXI Virtual FIFO Controller core (VFIFO) is a high performance core that implements multiple AXI4-Stream FIFOs. The memory storage for data contained in the FIFOs comes from an attached AXI4 slave memory controller. The VFIFO core manages multiple sets of read and write address pointers to emulate the behavior of multiple independent FIFOs.

See the *LogiCORE IP AXI Virtual FIFO Controller Product Guide* (PG038) [Ref 11] for more information.

An AXI4 slave memory controller with external memory can provide large depths of external SRAM or DDR memory. VFIFO is useful in applications using PCIe, DSP, video, or Ethernet that require FIFOs that are deeper than can be otherwise constructed from an on-chip block RAM memory, distributed RAM memory, or external chips.

The virtual FIFO controller can send and receive multiplexed streams to implement up to 8 logical AXI4-Stream FIFOs.

It can be used in conjunction with the [AXI4-Stream Interconnect Core IP](#) to route the data to each endpoint IP as shown in [Figure 3-9](#).

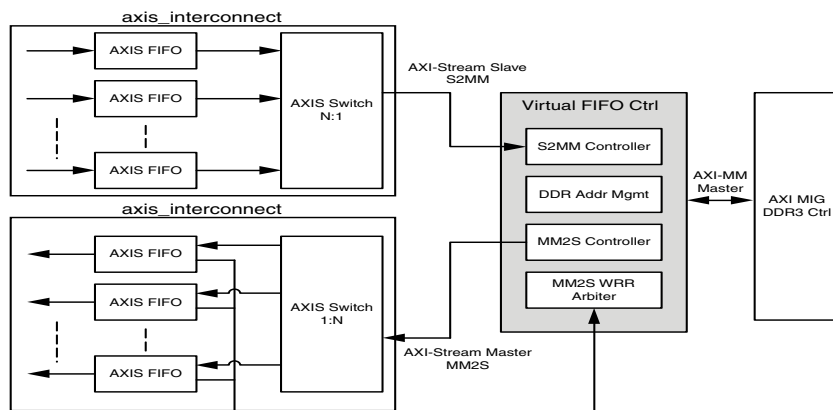

Figure 3-9: AXI4-Stream with Virtual FIFO Controller

The AXI4-Stream interconnect can also perform local FIFO buffering, clock conversion, and width conversion to adapt the interface of the stream endpoints to the data path of the virtual FIFO controller and the AXI memory controller

DataMover

The AXI DataMover is a key AXI infrastructure IP that enables high throughput transfer of data between the AXI4 memory-mapped and AXI4-Stream domains. It provides Memory Map-to-Stream (MM2S) and Stream-to-Memory-Map (S2MM) functions that operate independently. The DataMover IP has the following features:

- AXI4 Compliant
- Primary AXI4 data width support of 32, 64, 128, 256, 512, and 1,024 bits
- Primary AXI4-Stream data width support of 8, 16, 32, 64, 128, 256, 512 and 1,024 bits
- Parameterized Memory Map Burst Lengths of 2, 4, 8, 16, 32, 64, 128, and 256 data beats
- Optional Unaligned Address access; Up to 64 bit address support
- Optional General Purpose Store-And-Forward in both Memory Map to Stream (MM2S) and Stream to Memory Map (S2MM)
- Optional Indeterminate Bytes to Transfer (BTT) mode in S2MM
- Supports synchronous/asynchronous clocking for Command/Status interface

See the *LogiCORE IP AXI DataMover Product Guide* (PG022) [Ref 7] for more information.

The following figures show block diagrams of the AXI DataMover core.

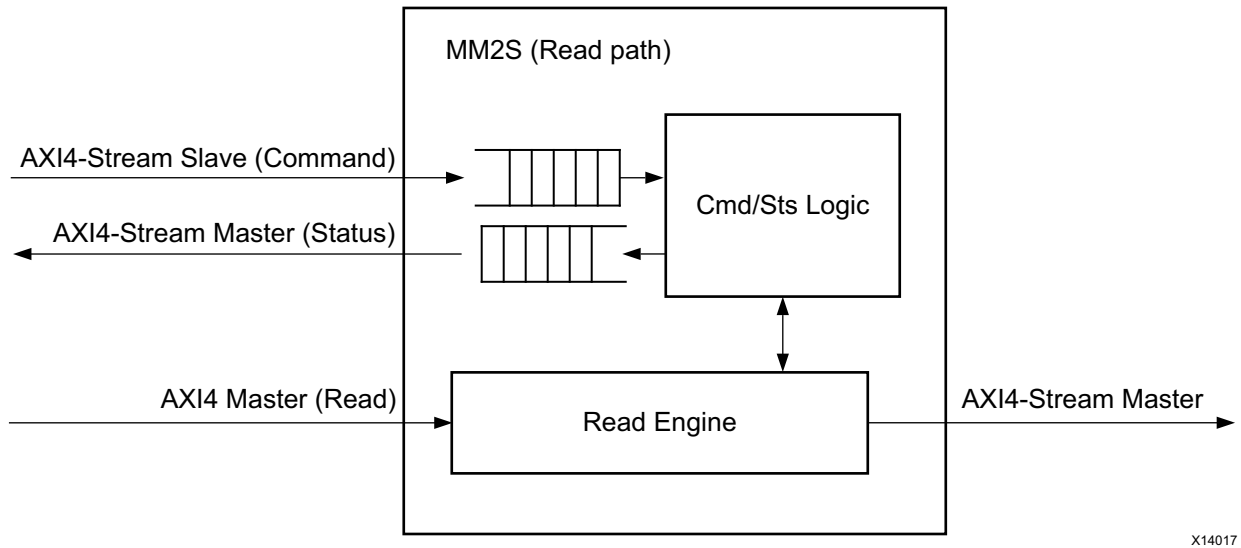

X14017

Figure 3-10: DataMover MM2S Read Path

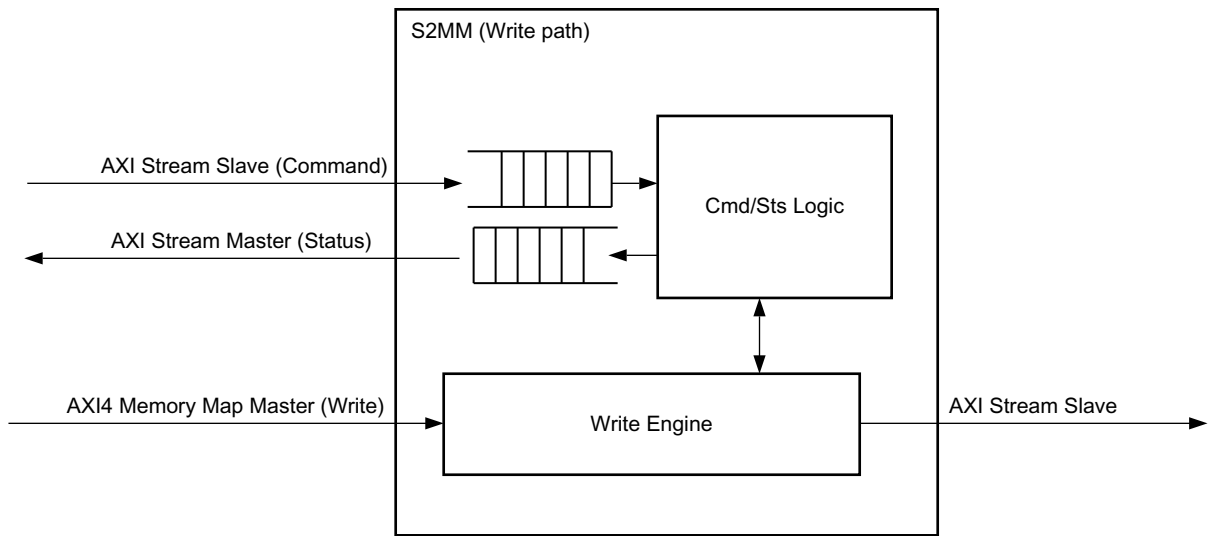

X13224

Figure 3-11: DataMover S2MM Write Path

There are two sub-blocks:

- **MM2S:** This block handles transactions from the AXI memory map to AXI4-Stream domain. It has its dedicated AXI4-Stream compliant command and status queues, reset block and error signals. Based on command inputs, the MM2S block issues a read request on the AXI memory-map interface.
 - Optionally, you can store read data inside the MM2S block.

- Optionally, data path interfaces (AXI4 read and AXI4-Stream master) can be made asynchronous to command and status interfaces (AXI4-Stream command and AXI4-Stream status).
- **S2MM**: This block handles transactions from the AXI4-Stream to AXI memory map domain. It has its dedicated AXI4-Stream compliant command and status queues, reset block and error signals. Based on command inputs and input data from the AXI4-Stream interface, the **S2MM** block issues a write request on the AXI memory map interface.
 - Optionally, you can store input stream data inside a **S2MM** block.
 - Optionally, you can make data path interfaces (AXI4 read and AXI4-Stream master) asynchronous to command and status interfaces (AXI4-Stream command and AXI4-Stream status).

AXI4 DMA

The AXI DMA engine provides high performance direct memory access between system memory and AXI4-Stream type target peripherals. The AXI DMA provides Scatter Gather (SG) capabilities, allowing the CPU to offload transfer control and execution to hardware automation.

See the *AXI DMA LogiCORE IP Product Guide* (PG021) [Ref 29] for more information.

The AXI DMA as well as the SG engines are built around the AXI DataMover helper core (shared sub-block) that is the fundamental bridging element between AXI4-Stream and AXI4 memory-mapped buses.

AXI4 DMA provides independent operation between the Transmit channel Memory-Map to Slave (**MM2S**) and the Receive channel Slave to Memory Map (**S2MM**), and provides optional independent AXI4-Stream interfaces for offloading packet metadata. An AXI control stream for **MM2S** provides user application data from the SG descriptors to be transmitted from AXI DMA.

Similarly, an AXI status stream for **S2MM** provides user application data from a source IP like AXI4 Ethernet to be received and stored in SG descriptors associated with the receive packet. In an AXI Ethernet application, the AXI4 control stream and AXI4 status stream provide the necessary functionality for performing checksum offloading.

AXI DMA provides optional SG descriptor queuing, allowing fetching and queuing of up to four descriptors internally. This allows for very high bandwidth data transfer on the primary data buses.

AXI DMA Interfaces

The Xilinx implementation for DMA makes extensive use of the AXI4 capabilities. The following table summarizes the eight AXI4 interfaces used in the AXI DMA function.

Table 3-1: AXI DMA Interfaces

Interface	AXI Type	Data Width	Description
Control	AXI4-Lite slave	32	An AXI4-Lite slave used to access the AXI DMA internal registers. This is generally used by the System Processor to control and monitor the AXI DMA operations.
Scatter Gather	AXI4 master	32	An AXI4 memory-mapped master used by the AXI4 DMA to Read DMA transfer descriptors from system memory and write updated descriptor information back to system memory when the associated transfer operation is complete.
Data MM Read	AXI4 Read master	32, 64, 128, 256, 512, 1024	Transfers payload data for operations moving data from the memory-mapped side of the DMA to the Main Stream output side.
Data MM Write	AXI4 Write master	32, 64, 128, 256, 512, 1024	Transfers payload data for operations moving data from the Data Stream In interface of the DMA to the memory-mapped side of the DMA.
Data Stream Out	AXI4-Stream master	32, 64, 128, 256, 512, 1024	Transfers data read by the Data MM Read interface to the target receiver IP using the AXI4-Stream protocol.
Data Stream In	AXI4-Stream slave	32, 64, 128, 256, 512, 1024	Received data from the source IP using the AXI4-Stream protocol. Transferred the received data to the Memory-Map system using the Data MM Write Interface.
Control Stream Out	AXI4-Stream master	32	The Control stream Out is used to transfer control information embedded in the TX transfer descriptors to the target IP.
Status Stream In	AXI4-Stream slave	32	The Status Stream In receives RX transfer information from the source IP and updates the data in the associated transfer descriptor and written back to the System Memory using the Scatter Gather interface during a descriptor update.

Central DMA

Xilinx provides a Central DMA core for AXI interfaces. The following block diagram shows a typical embedded system architecture incorporating the AXI (AXI4 and AXI4-Lite) Central DMA. See the *AXI Central Direct Memory Access LogiCORE IP Product Guide* (PG034) [Ref 8] for more information.

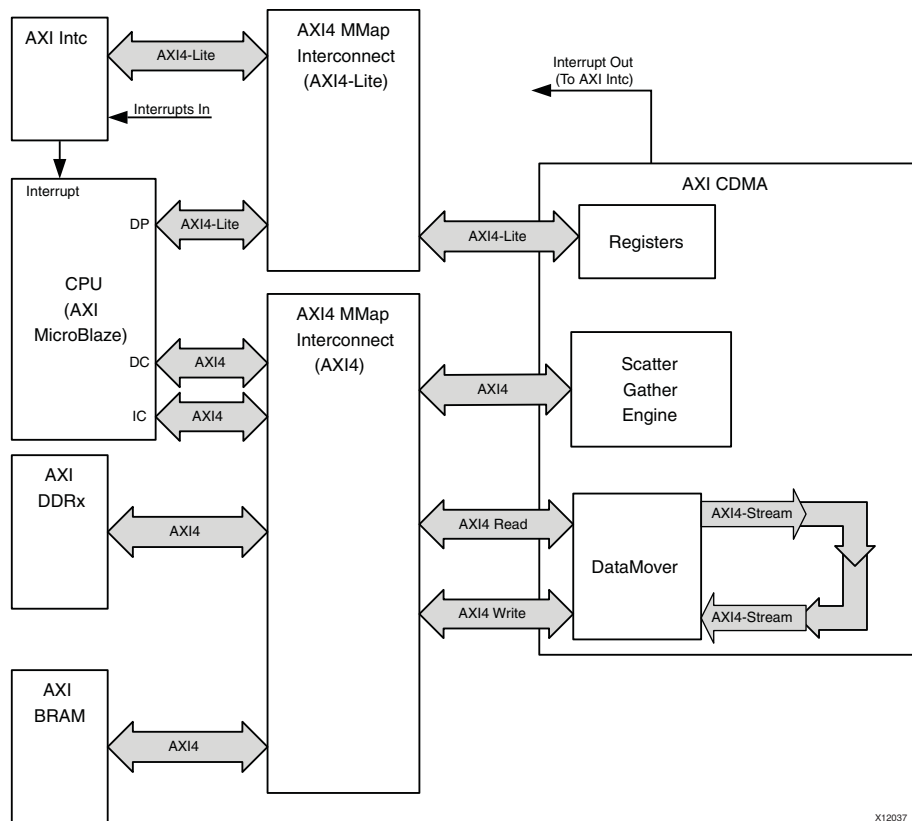

Figure 3-12: Typical Use Case for AXI Central DMA

The AXI4 Central DMA performs data transfers from one memory-mapped space to another memory-mapped space using high speed, AXI4, bursting protocol under the control of the system microprocessor.

AXI Central DMA Summary

The AXI Central DMA provides simple transfer mode operations. The Central DMA does the following:

- Performs the transfer
- Generates an interrupt when the transfer is complete
- Waits for the microprocessor to program and start the next transfer

The AXI Central DMA includes an optional data realignment function for 32- and 64-bit bus widths. This feature allows addressing independence between the transfer source and destination addresses.

AXI Central DMA Scatter Gather Feature

The AXI Central DMA has an optional Scatter Gather (SG) feature.

SG enables the system CPU to offload transfer control to high-speed hardware automation that is part of the Scatter Gather engine of the Central DMA. The SG function fetches and executes pre-formatted transfer commands (buffer descriptors) from system memory as fast as the system allows with minimal required CPU interaction. The architecture of the Central DMA separates the SG AXI4 bus interface from the AXI4 data transfer interface so that buffer descriptor fetching and updating can occur in parallel with ongoing data transfers, which provides a significant performance enhancement.

DMA transfer progress is coordinated with the system CPU using a programmable and flexible interrupt generation approach built into the Central DMA.

AXI Centralized DMA lets you switch between using Simple Mode transfers and SG-assisted transfers using the programmable register set.

The AXI Central DMA is built around the AXI DataMover, which is the fundamental bridging element between AXI4-Stream and AXI4 memory-mapped buses. In the case of AXI Centralized DMA, the output stream of the DataMover is internally looped back to the input stream. The SG feature is based on the Xilinx SG helper core used for all Scatter Gather enhanced AXI DMA products.

Central DMA Configurable Features

The AXI4 Centralized DMA lets you trade-off the feature set implemented with the device resource utilization budget. The following features are parameterizable at device implementation time:

- Use DataMover Lite for the main data transport (Data Realignment Engine (DRE) and SG mode are not supported with this data transport mechanism).
- Include or omit the Scatter Gather function.
- Include or omit the DRE function (available for 32- and 64-bit data transfer bus widths only).
- Specify the main data transfer bus width (32, 64, 128, 256, 512, and 1024 bits).
- Specify the maximum allowed AXI4 burst length for the DataMover to use during data transfers.

Video DMA

The AXI4 protocol Video DMA (VDMA) provides a high bandwidth solution for Video applications. It is a similar implementation to the Ethernet DMA solution.

The following figure shows a top-level AXI4 VDMA block diagram.

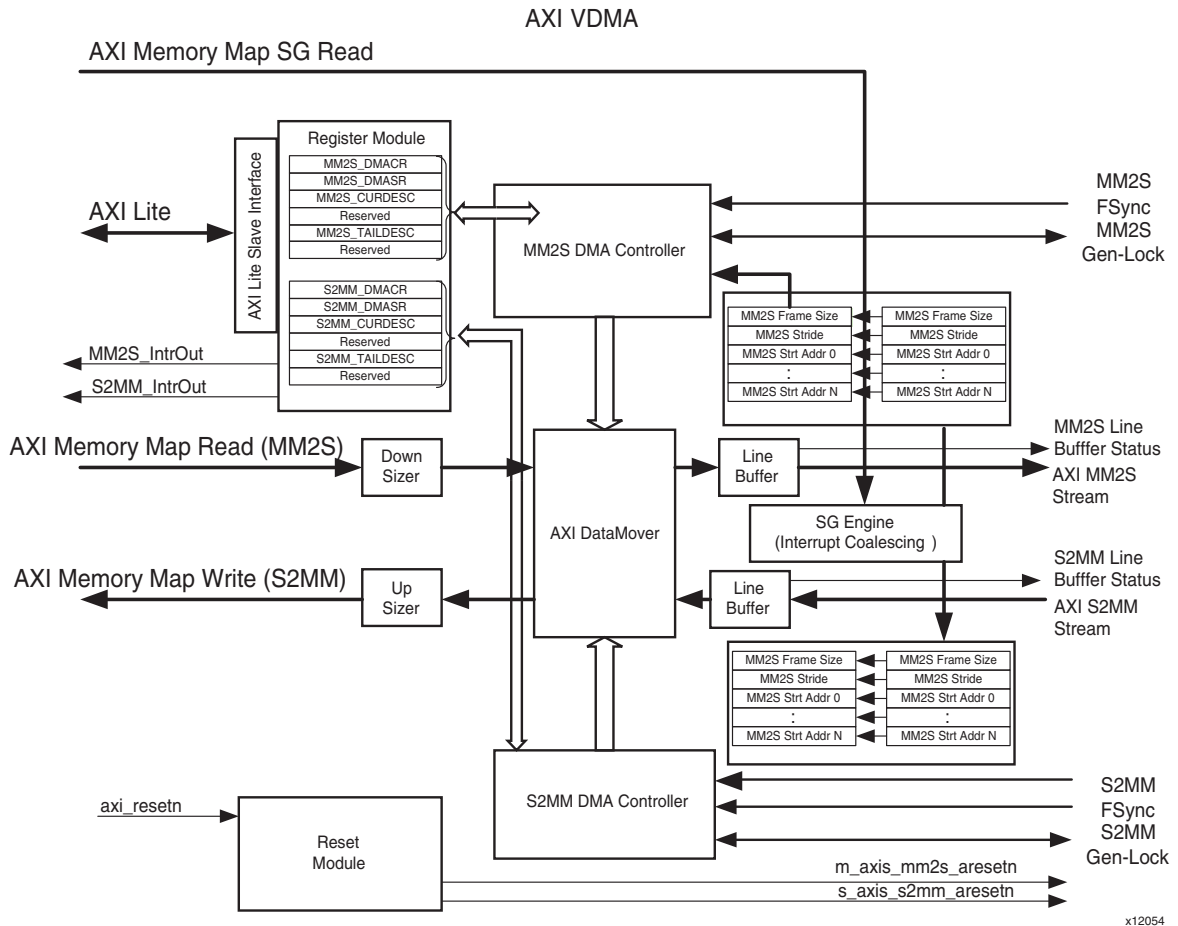

Figure 3-13: AXI VDMA High-Level Block Diagram

The following figure illustrates a typical system architecture for the AXI VDMA.

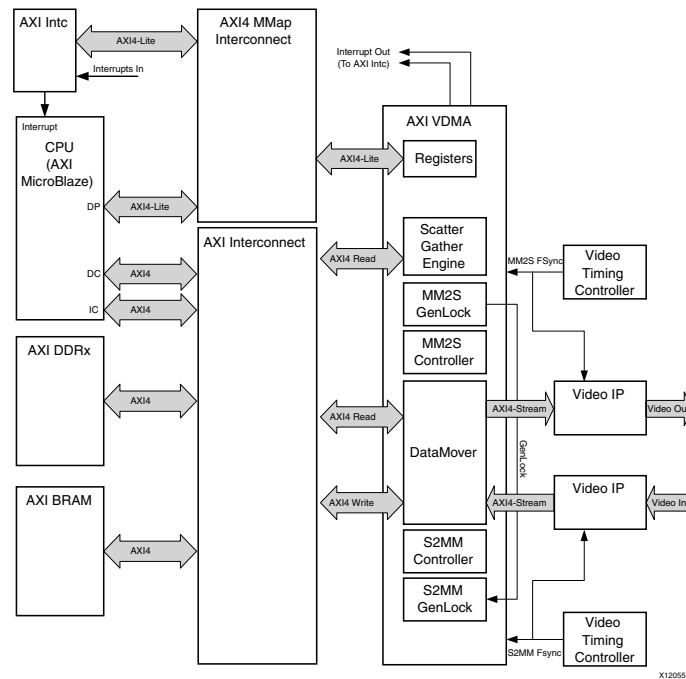

Figure 3-14: Typical Use Case for AXI VDMA and Video IP

AXI VDMA Summary

The AXI VDMA engine provides high performance direct memory access between system memory and AXI4-Stream type target peripherals. The AXI VDMA provides Scatter Gather (SG) capabilities also, which allows the CPU to offload transfer control and execution to hardware automation. The AXI VDMA and the SG engines are built around the AXI DataMover helper core which is the fundamental bridging element between AXI4-Stream and AXI4 memory-mapped buses.

AXI VDMA provides the following:

- Circular frame buffer access for up to 32 frame buffers and provides the tools to transfer portions of video frames or full video frames.
- The ability to *park* on a frame, allowing the same video frame data to be transferred repeatedly.
- Independent frame synchronization and an independent AXI clock, allowing each channel to operate on a different frame rate and different pixel rate. To maintain synchronization between two independently functioning AXI VDMA channels, there is an optional *Gen-Lock* synchronization feature. Gen-Lock provides a method of synchronizing AXI VDMA slaves automatically to one or more AXI VDMA masters so the slave does not operate in the same video frame buffer space as the master.

In this mode, the slave channel skips or repeats a frame automatically. You can configure either channel to be a Gen-Lock slave or a Gen-Lock master.

For video data transfer, the AXI4-Stream ports can be configured from 8 bits up to 1024 bits wide in multiples of 8. For configurations where the AXI4-Stream port is narrower than the associated AXI4 memory-mapped port, the AXI VDMA upsizes or downsizes the data providing full bus width burst on the memory-map side. It also supports an asynchronous mode of operation where all clocks are treated asynchronously.

VDMA AXI4 Interfaces

Table 3-2: AXI VDMA Interfaces

Interface	AXI Type	Data Width	Description
Control	AXI4-Lite slave	32	Accesses the AXI VDMA internal registers. This is generally used by the System Processor to control and monitor the AXI VDMA operations.
Scatter Gather	AXI4 master	32	An AXI4 memory-mapped master that is used by the AXI VDMA to read DMA transfer descriptors from System Memory. Fetched Scatter Gather descriptors set up internal video transfer parameters for video transfers.
Data MM Read	AXI4 Read master	32, 64, 128, 256, 512, 1024	Transfers payload data for operations moving data from the memory-mapped side of the DMA to the Main Stream output side.
Data MM Write	AXI4 Write master	32, 64, 128, 256, 512, 1024	Transfers payload data for operations moving data from the Data Stream In interface of the DMA to the memory-mapped side of the DMA.
Data Stream Out	AXI4-Stream master	8,16, 32, 64, 128, 256, 512, 1024	Transfers data read by the Data MM Read interface to the target receiver IP using the AXI4-Stream protocol.
Data Stream In	AXI4-Stream slave	8, 16, 32, 64, 128, 256, 512, 1024	Receives data from the source IP using the AXI4-Stream protocol. The data received is then transferred to the Memory Map system using the Data MM Write Interface.

Simulating IP

You can use the Vivado Lab Edition to test and verify the IP capabilities when attached to a Xilinx board with a JTAG connection.

See the following documents for more information:

- *Vivado Design Suite Tutorial: Programming and Debugging* (UG936) [Ref 28]
- *Vivado Design Suite User Guide: Programming and Debugging* (UG908) [Ref 34]

Also, simulating customized IP lets you see if you are achieving the results you expect. See the following for more information about simulation options:

- *Vivado Design Suite User Guide: Logic Simulation* (UG900) [Ref 32]
- This [link](#) to “Simulating IP” in the *Vivado Design Suite User Guide: Designing with IP* (UG896) [Ref 30]

The following section describes the IP that assist with debugging customized Vivado IP.

Using Debug and IP

The Vivado Lab Edition are debugging tools that are available in the Vivado Design Suite. The features that are included in the Vivado Lab Edition include:

- Vivado logic analyzer (see [ILA](#))
- Vivado serial I/O analyzer (see [VIO](#))
- IBERT serial analyzer (see [IBERT](#))
- JTAG to AXI (see [JTAG-to-AXI](#))

Also, see [Ease of Use and Debug Optimization Guidelines in Chapter 6](#).

ILA

The integrated logic analyzer (ILA) also called *Vivado logic analyzer*, lets you perform in-system debugging of post-implemented designs on an FPGA. Use this feature when you need to monitor signals in a design. You can also use this feature to trigger on hardware events and capture data at system speeds. You can instantiate the ILA core in your RTL code or insert the core, post-synthesis, in the Vivado design flow. See the *Integrated Logic Analyzer LogiCORE IP Product Guide* (PG172) [Ref 22], for more information.

VIO

The virtual input/output (VIO) debug feature, also called the *Vivado serial I/O analyzer* can both monitor and drive internal FPGA signals in real time. In the absence of physical access to the target hardware, you can use this debug feature to drive and monitor signals that are present on the real hardware.



IMPORTANT: *This debug core must be instantiated in the RTL code; consequently, you need to know what nets to drive.*

The IP Catalog lists this core under the Debug category. See the *Virtual Input/Output LogiCORE IP Product Guide* (PG159) [Ref 21] for more information.

IBERT

The integrated bit error ratio tester (IBERT) serial analyzer enables in-system serial I/O validation and debug. This allows you to measure and optimize your high-speed serial I/O links in your FPGA-based system.



RECOMMENDED: Use the IBERT Serial Analyzer when you are interested in addressing a range of in-system debug and validation problems from simple clocking and connectivity issues to complex margin analysis and channel optimization issues. Use the Vivado IBERT serial analyzer design when you are interested in measuring the quality of a signal after a receiver equalization is applied to the received signal. This ensures that you are measuring at the optimal point in the TX-to-RX channel and thereby real and accurate data.

You can access this design by selecting configuring, and generating the IBERT core from the IP catalog and selecting the **Open Example Design** feature of this core.

See details on the IP in the following documents:

- *IBERT for 7 Series GTX Transceivers LogiCORE IP Product Guide* (PG132) [\[Ref 17\]](#)
- *IBERT for 7 Series GTP Transceivers LogiCORE IP Product Guide* (PG133) [\[Ref 18\]](#)
- *IBERT for 7 Series GTH Transceivers LogiCORE IP Product Guide* (PG152) [\[Ref 20\]](#)

JTAG-to-AXI

The JTAG-to-AXI debug feature generates AXI transactions that interact with various AXI4 and AXI4-Lite slave cores in a system that is running in hardware.



IMPORTANT: Use this core to generate AXI transactions and debug and to drive AXI signals internal to an FPGA at run time. You can use this core in IP designs without processors as well. The IP Catalog lists the core under the **Debug** category.

See *Vivado Design Suite Tutorial: Programming and Debugging* (UG936) [\[Ref 36\]](#), for a demonstration of JTAG-to-AXI debug.

Performance Monitor IP

The LogiCORE™ IP AXI Performance Monitor measures major performance metrics for the AMBA AXI system. The Performance Monitor measures bus latency of a specific master/slave (AXI4/AXI3/AXI4-Stream/AXI4-Lite) in a system, the amount of memory traffic for specific durations, and other performance metrics. This core can also be used for real-time profiling for software applications. See the *LogiCORE IP AXI Performance Monitor Product Guide* (PG037) [Ref 10] for more information.

The AXI Performance Monitor (APM) supports three modes for analyzing system behavior on AXI interfaces:

- **Advanced:** Advanced mode supports two major functions on AXI4/AXI3/AXI4-Stream/AXI4-Lite interfaces.
 - **Event Logging:** The APM logs the specified AXI monitor slots' events (configured by the user) and external system events coming in to the streaming FIFO. This data can be used by the system processor or external host application to reconstruct the AXI transaction for analyzing system behavior/performance.
 - **Event Counting:** The APM supports monitoring AXI slots for counting events associated with AXI interface transaction and external events. The included event counters can be set, read by the software, and used to analyze and enhance the system performance. The core also has a global clock counter for real-time profiling for software applications.
- **Profile:** Profile mode provides the event counting functionality of the APM with less user configuration to analyze system behavior on AXI4/AXI3/AXI4-Lite interfaces. It provides event counting for fixed metrics on each slot. The number of counters per slot and the metric for each counter are pre-defined. Profile mode does not support the AXI4-Stream interface and external event metrics.
- **Trace:** Trace mode provides event logging functionality of the APM with less user configuration than Advanced mode. All the flags are enabled or disabled through the Vivado GUI options when generating the core and cannot be modified after core generation. Trace mode does not support the AXI4-Stream interface.

The top-level block diagram of the AXI Performance Monitor in advanced mode is shown in [Figure 3-15](#).

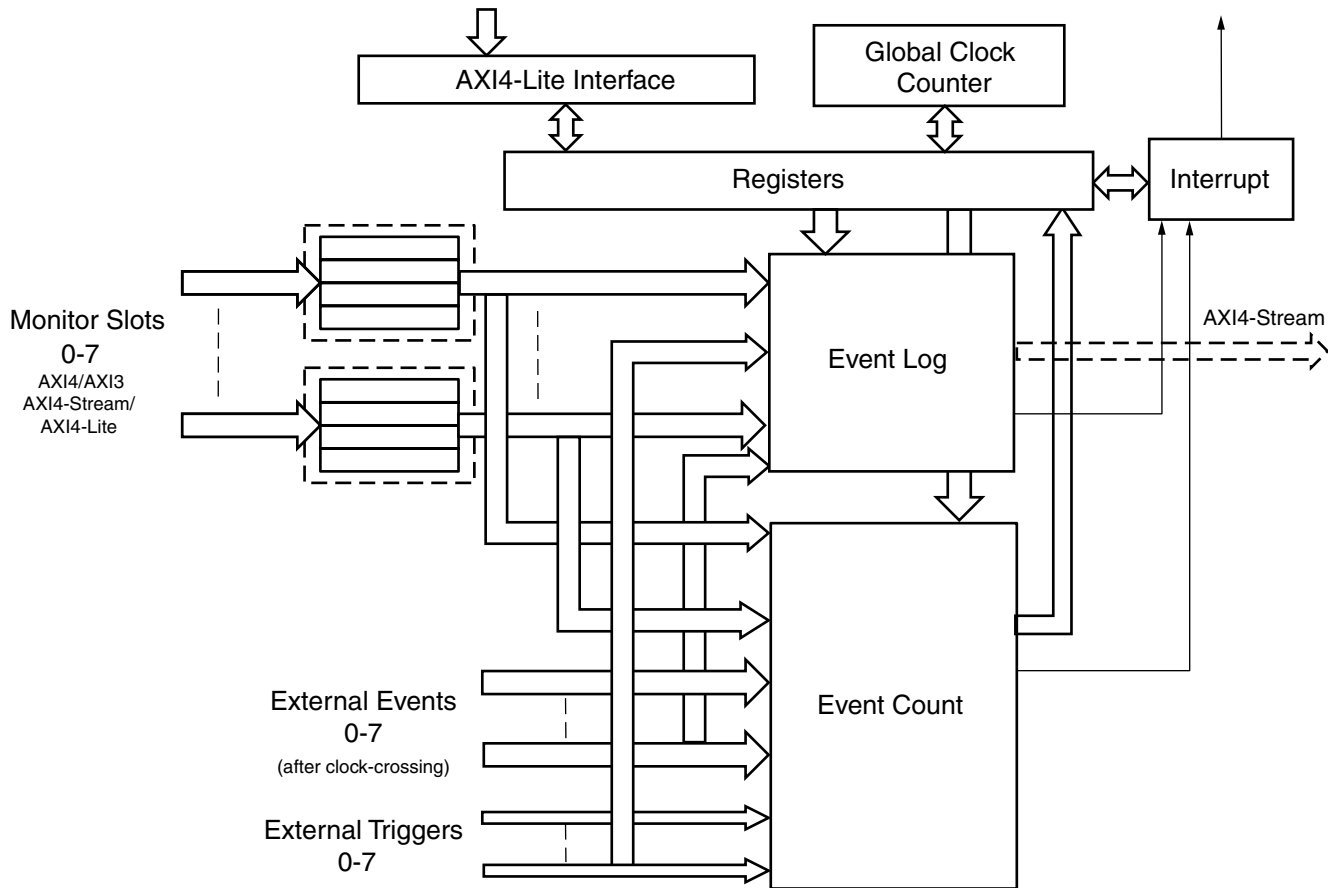

X12947

Figure 3-15: Block Diagram of AXI Performance Monitor

Protocol Checkers

The AXI Protocol Checker and AXI4-Stream Protocol Checker IP monitor AXI and AXI4-Stream interfaces. When attached to an interface, the cores actively check for protocol violations and provide an indication of which violation occurred.

The AXI and AXI4-Stream Protocol Checkers:

- Are useful to add to a system to monitor for protocol violations that could lead to incorrect behavior.
- Can be used for simulation and hardware-based debug.

See the following product guides for more information:

- *AXI Protocol Checker LogiCORE IP Product Guide for Vivado Design Suite* (PG101) [Ref 15]
- *AXI4-Stream Protocol Checker LogiCORE IP Product Guide for Vivado Design Suite* (PG145) [Ref 19]

The following figure is a block diagram of the AXI Protocol Checker.

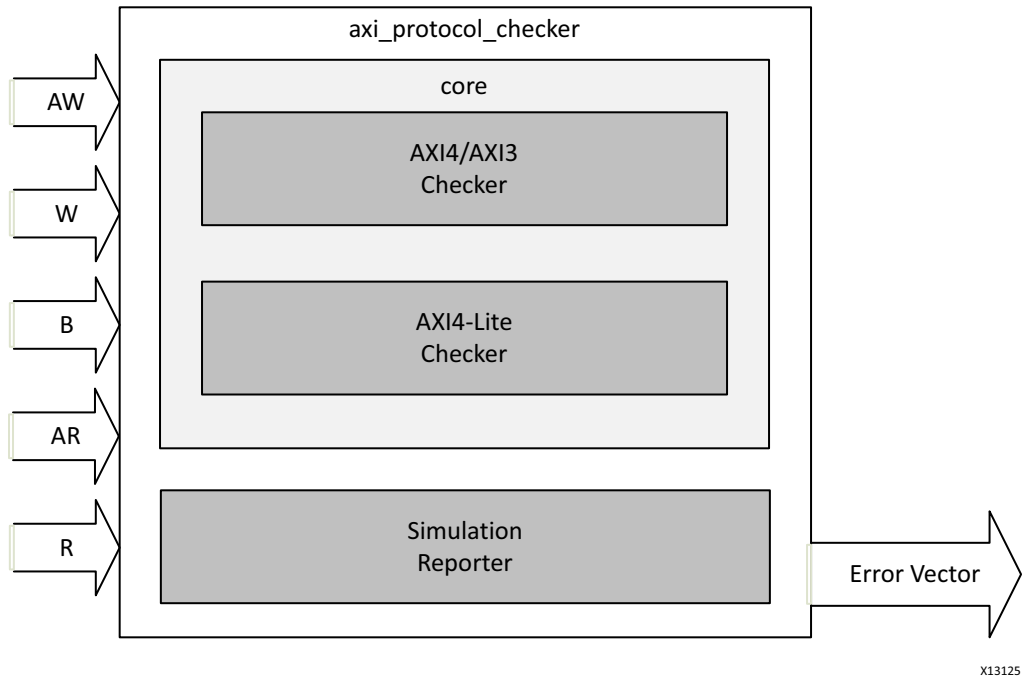

Figure 3-16: AXI Protocol Checker Block Diagram

The following figure is the block diagram of the AXI4-Stream Protocol Checker.

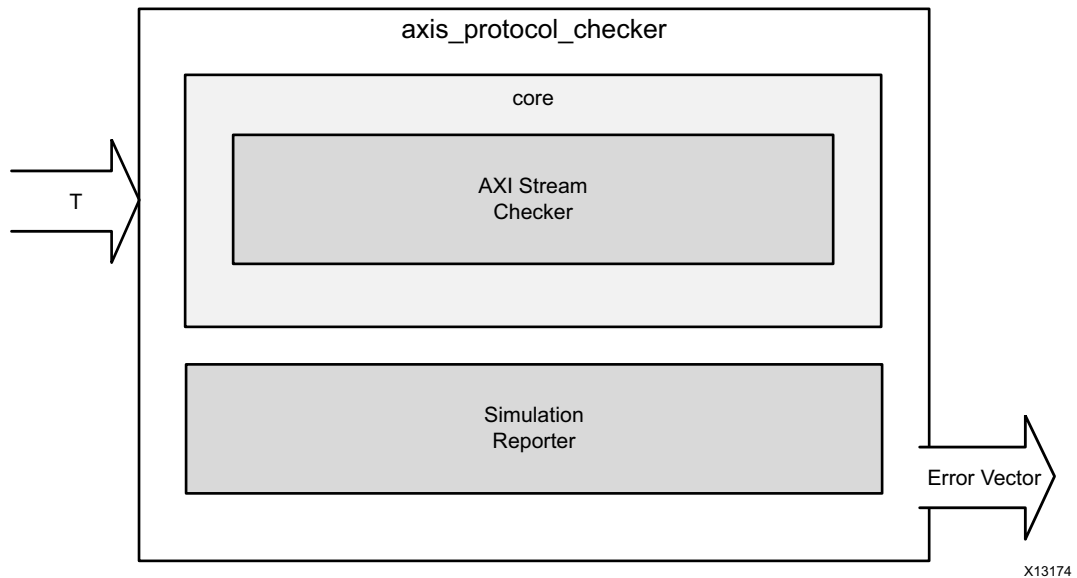

Figure 3-17: AXI4-Stream Protocol Checker

The error vector identifies the specific protocol violation to the console. The simulation report provides simulation messages in the log file.

AXI Verification IP

The Xilinx AXI Verification IP (VIP) core has been developed to support the simulation of customer designed AXI-based IP. The AXI VIP core supports three versions of the AXI protocol (AXI3, AXI4, and AXI4-Lite). The AXI VIP is unencrypted SystemVerilog source that contains a SystemVerilog class library and synthesizable RTL. The embedded RTL interface is controlled by the AXI VIP through a virtual interface. AXI transactions are constructed in the verification environment of the customer and passed to the AXI driver class. The driver class then manages the timing and drives the content on the interface.

The following sections list the features and use cases for the AXI VIP IP. See the *AXI Verification LogiCORE IP Product Guide* (PG267) [Ref 24] for a full description of the IP.



IMPORTANT: *The AXI Verification IP is written in SystemVerilog and uses randomization. Not all third-party simulators support SystemVerilog and randomization. Check Vivado Design Suite User Guide: Release Notes, Installation, and Licensing (UG973) [Ref 29] for information about third-party compatibility to the AXI VIP.*

Features

- Supports all protocol data widths, address widths, transfer types, and responses
- Transaction-level protocol checking (burst type, length, size, lock type, and cache type)
- ARM®-based protocol transaction level checker for tools that support assertion property
- Behavioral SystemVerilog Syntax
- SystemVerilog class-based API
- Synthesizes to nets and constant tie-offs

Uses

The AXI Verification IP (VIP) core is used in the following manner:

- Generating master AXI commands and write payload
- Generating slave AXI read payload and write responses
- Checking protocol compliance of AXI transactions

The AXI VIP can be configured in three different modes:

- AXI master VIP
- AXI slave VIP
- AXI pass-through VIP

The following figure shows the AXI master VIP which generates AXI commands and write payload and sends it to the AXI system.

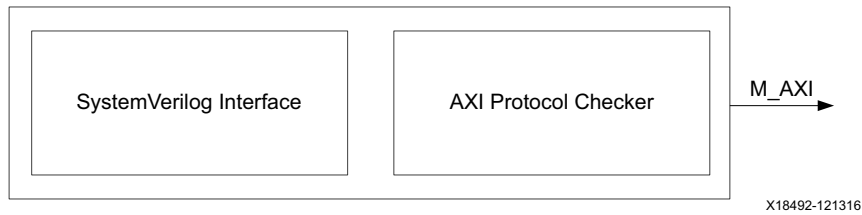

Figure 3-18: AXI Master VIP

The following figure shows the AXI slave VIP which responds to the AXI commands and generates read payload and write responses.

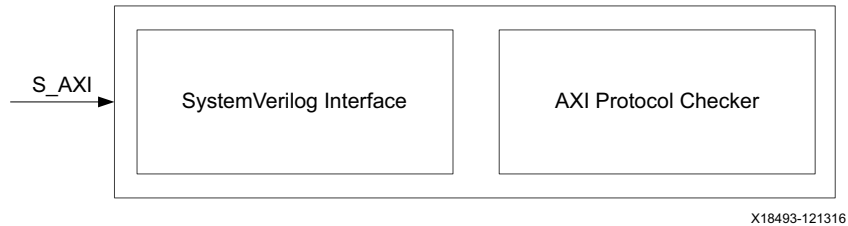

Figure 3-19: AXI Slave VIP

The following figure shows the AXI pass-through VIP which protocol checks all AXI transactions that pass through it. The IP can be configured to behave in the following modes:

- Monitor only
- Master
- Slave

The AXI protocol checker does not exist in the synthesized netlist.

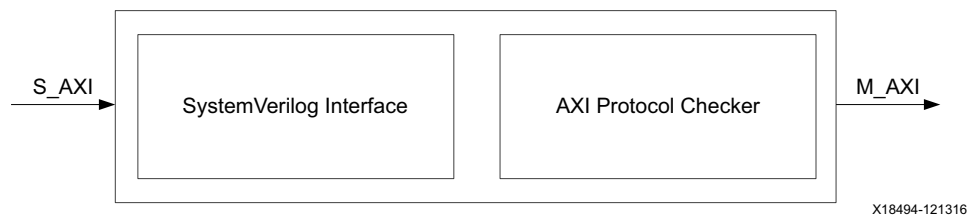

Figure 3-20: AXI Pass-Through VIP



IMPORTANT: When using the Vivado® simulator, the AXI Protocol Checker IP [Ref 3] is used in place of the ARM AMBA Assertions.

AXI4-Stream Verification IP

The AXI4-Stream Verification IP (VIP) core supports the simulation of customer designed AXI-based IP. The AXI4-Stream VIP core supports the AXI4-Stream protocol. The AXI4-Stream VIP is unencrypted SystemVerilog source that includes a SystemVerilog class library and synthesizable RTL.

The embedded RTL interface is controlled by the AXI4-Stream VIP through a virtual interface. AXI4-Stream transactions are constructed in the customer's verification environment and passed to the AXI4-Stream driver class. The driver class then manages the timing and driving the content on the interface.

The following sections briefly describe the IP. See the *AXI4-Stream Verification IP LogiCORE IP Product Guide* (PG277) [Ref 25] for more information.

Features

- Supports the following widths:
 - Data widths up to 512 bytes
 - ID widths up to 32 bits
 - DEST widths up to 32 bits
- ARM-based transaction-level protocol checking for tools that support assertion property
- Behavioral SystemVerilog Syntax
- SystemVerilog class-based API

The AXI4-Stream Verification IP (VIP) core is used in the following manner:

- Generating master AXI4-Stream commands and write payload
- Generating slave AXI4-Stream read payload and write responses
- Checking protocol compliance of AXI4-Stream transactions

Overview

The AXI4-Stream VIP can be configured in three different modes:

- AXI4-Stream master VIP
- AXI4-Stream slave VIP
- AXI4-Stream pass-through VIP

The following figure shows the AXI4-Stream master VIP that generates AXI4-Stream payloads and sends it to the AXI4-Stream system.

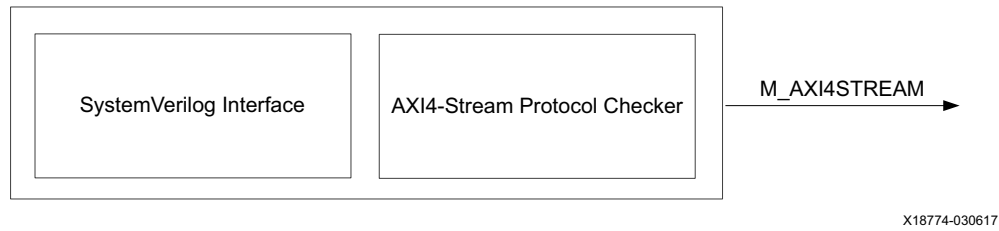

Figure 3-21: AXI4-Stream Master VIP

The following figure shows the AXI4-Stream slave VIP that responds to the AXI4-Stream and generates a Ready signal.

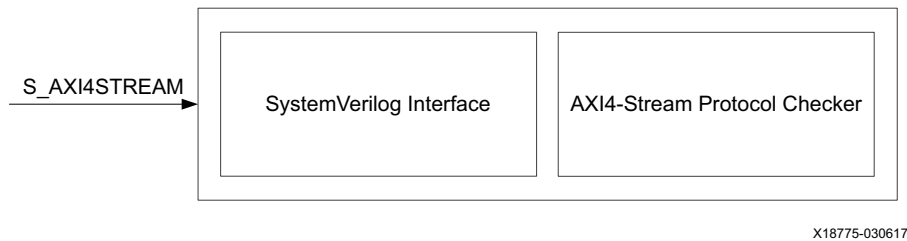

Figure 3-22: AXI4-Stream Slave VIP

The following figure shows the AXI4-Stream pass-through VIP that protocol checks all AXI4-Stream transactions that pass through it. The IP can be configured to behave in the following modes:

- Monitor only
- Master
- Slave

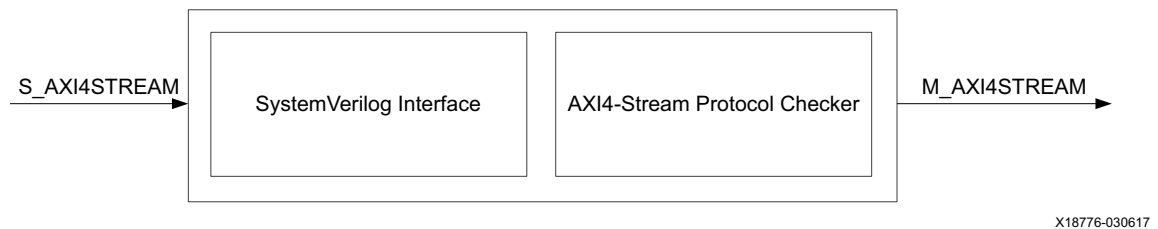

Figure 3-23: AXI4-Stream Pass-Through VIP

Zynq-7000 AP SoC Verification IP

When designing Zynq[®]-7000 All Programmable SoC processor-based applications, a `processing_system7` Verification IP (VIP) is available. This VIP enables functional verification of the processor logic (PL) by mimicking the processor system (PS) and PL interfaces in PS logic. This VIP provides a package of encrypted Verilog modules. VIP operation is controlled by using a sequence of Verilog tasks contained in a Verilog-syntax file. See the *Zynq-7000 All Programmable SoC Verification IP* (DS940) [Ref 5] for more information.

Also, the following Vivado QuickTake Video is available to help you understand how to use the Zynq-7000 processor VIP.



VIDEO: [Vivado Design Suite QuickTake Video: How to Use the Zynq-7000 Verification IP to Verify and Debug using Simulation](#)

Features

- Pin compatible and Verilog-based simulation model.
- Supports all AXI interfaces.
 - AXI 3.0 compliant.
- 32/64-bit Data-width for `AXI_HP`, 32-bit for `AXI_GP`, and 64-bit for `AXI_ACP`.
- Sparse memory model (for DDR) and a RAM model (for OCM).
- System Verilog task-based API.
- Delivered in Vivado[®] Design Suite.
- Blocking and non-blocking interrupt support.
- ID width support as per the Zynq-7000 specification.
- Support for `FIXED`, `INCR`, and `WRAP` transaction types.
- Support for all Zynq-7000 supported burst lengths and burst sizes.
- Protocol checking, provided by the AXI VIP models.
- Read/Write request capabilities.
- System Address Decode for OCM/DDR transactions.

Additional Features

- System Address Decode for Register Map Read transactions (only default value of the registers can be read).
- Support for static remap for `AXI_GP0` and `AXI_GP1`.
- Configurable latency for Read/Write responses.
- First-level arbitration scheme based on the priority indicated by the AXI QoS signals.

- Data path connectivity between any AXI master in PL and the PS memories and register map.
- Parameters to enable and configure AXI Master and Slave ports.
- APIs to set the traffic profile and latencies for different AXI Master and Slave ports.
- Support for FPGA logic clock generation.
- Soft Reset Control for the PL.
- API support to pre-load the memories, read/wait for the interrupts from PL, and checks for certain data pattern to be updated at certain memory location.
- All unused interface signals that output to the PL are tied to a valid value.
- Semantic checks on all other unused interface signals.

Limitations

The following features are not yet supported by Zynq-7000 APSoC VIP:

- Exclusive Access transfers are not supported on any of the slave ports.
- Read/Write data interleaving is not supported.
- Write access to the Register Map is not supported.
- Support for in-order transactions only.

MicroBlaze Debug Module

The MicroBlaze™ Debug Module (MDM):

- Enables JTAG-based debugging of one or more MicroBlaze processors.
- Instantiates one BSCAN primitive, or allows an external BSCAN to be used. In devices that contain more than one BSCAN primitive, MDM uses the USER2 BSCAN by default.
- Includes a UART with a configurable slave bus interface which can be configured for an AXI4-Lite interconnect. The UART TX and RX signals are transmitted over the FPGA JTAG port to and from the Xilinx® Microprocessor Debug (XMD) tool. The UART behaves in a manner similar to the LogiCORE™ IP AXI (UART) Lite core.
- Provides a configurable AXI4 master port for direct access to memory from JTAG. This allows fast program download, as well as transparent memory access when the connected MicroBlaze processors are executing.
- Allows software to control debug and observe debug status through the AXI4-Lite slave interface. This is particularly useful for software performance measurements and analysis, using the MicroBlaze extended debug functionality for performance monitoring.
- Includes a cross-trigger capability, which enables routing of trigger events between connected MicroBlaze processors, as well as an external interface compatible with the Zynq®-7000 Processing System.

The block diagram of the MicroBlaze Debug Module is shown in the following figure.

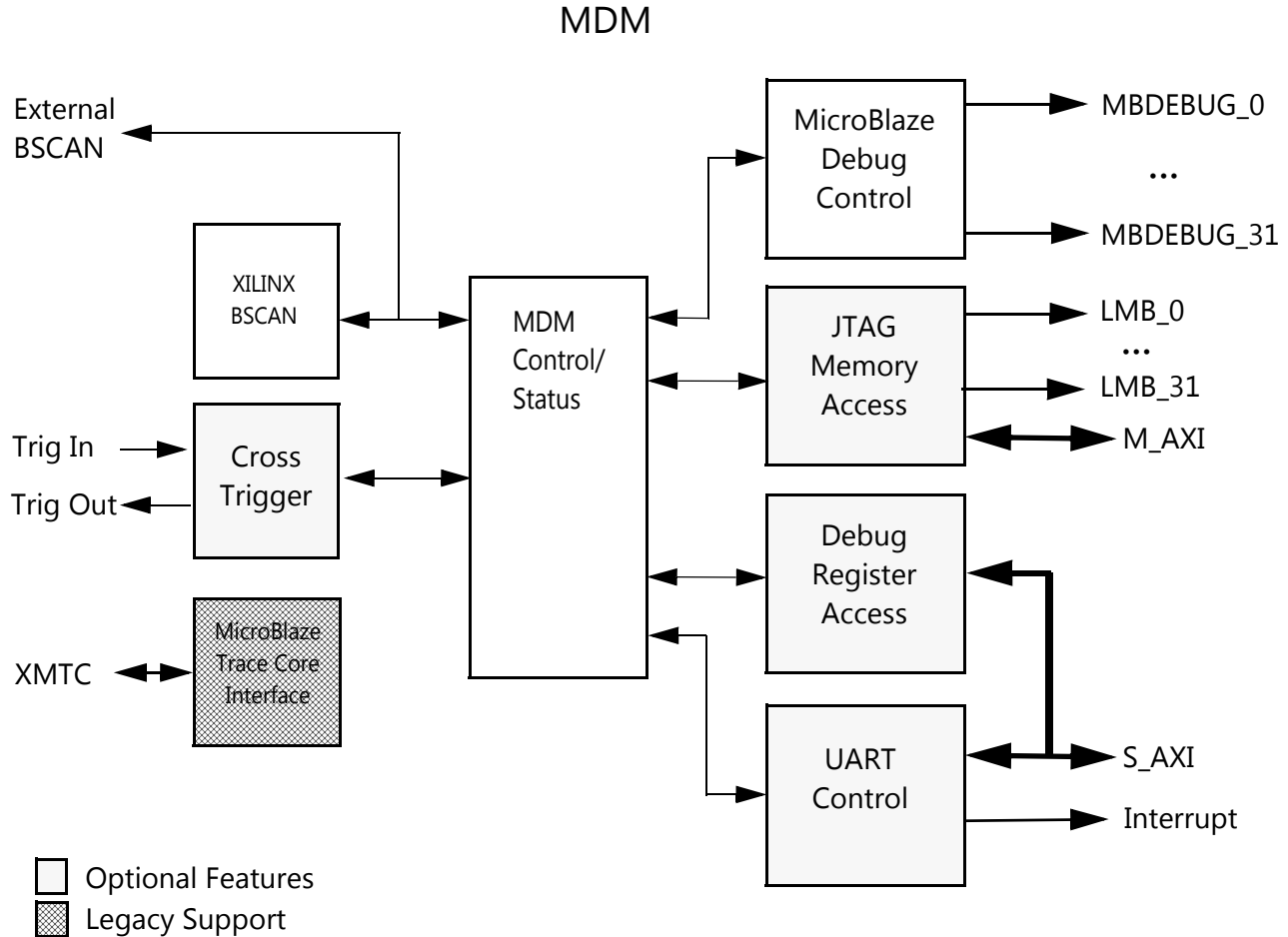

Figure 3-24: MicroBlaze Debug Module (MDM) Block Diagram

For more information, see the *MicroBlaze Debug Module (MDM) Product Guide* (PG115) [Ref 16].

Zynq UltraScale+ MPSoC Processor Device

This information is summarized from the *Zynq UltraScale+ MPSoC Technical Reference Manual* (UG1085) [Ref 40].

The Zynq® UltraScale+™ processor device interfaces to the cache-coherent interconnect (CCI) only to support the AXI coherency extension (ACE). ACE is an extension to the AXI protocol and provides the following enhancements:

- Support for hardware cache coherency.
- Barrier transactions that ensure transaction ordering.

System-level coherency enables the sharing of memory by system components without the software requirement to perform software cache maintenance to maintain coherency between caches. Regions of memory are coherent if writes to the same memory location by two components are observable in the same order by all components.

The ACE coherency protocol ensures that all masters observe the correct data value at any given address location by enforcing that only one copy exists whenever a store occurs to the location. After each store to a location, other masters can obtain a new copy of the data for their own local cache, allowing multiple copies to exist. See the ARM® AMBA® AXI and ACE protocol specification for a detailed overview.

PS-PL AXI Interfaces

The following table lists the AXI Interfaces in the Zynq UltraScale+ Processing System (PS) and Processor Logic (PL).

Table 3-3: PS-PL AXI Interfaces

Interface Name	Abbreviation	Type	Master Data	Width Master	ID Width	Usage Description
S_AXI_HP{0:3}_FPD	HP{0:3}	AXI4	PL	128/64/32	6	Non-coherent paths from PL to FPD main switch and DDR.
S_AXI_HPM0_LPD	PL_LPD	AXI4	PL	128/64/32	6	Non-coherent path from PL to IOP in LPD.
S_AXI_ACE_FPD	ACE	ACE	PL	128	6	Two-way coherent path between memory in PL and CCI.
S_AXI_ACP_FPD	ACP	AXI4	PL	128	5	I/O coherent with CCI. With L2 cache allocation.
S_AXI_HPC{0, 1}_FPD	HPC{0, 1}	AXI4	PL	128	6	I/O coherent with CCI. No L2 cache allocation.
M_AXI_HPM{0, 1}_FPD	HPM{0, 1}	AXI4	PS	128/64/32	16	FPD masters to PL slaves.
M_AXI_HPM0_LPD	LPD_PL	AXI4	PS	128/64/32	16	LPD masters to PL slaves.

Zynq-7000 All Programmable SoC Processor IP

This information is summarized from the *Zynq-7000 AP SoC Technical Reference Manual* (UG585) [Ref 32] to provide a quick reference to the AXI and Zynq-7000 connectivity features.

Choosing a Programmable Logic Interface

This section discusses various options to connecting Programmable Logic (PL) to the Processing System (PS). The main emphasis is on data movement tasks such as direct memory access (DMA).

PL Interface Comparison Summary

The following table presents a qualitative overview of data transfer use cases. The estimated throughput column reflects suggested maximum throughput in a single direction (read/write).

Table 3-4: Data Movement Method Comparison Summary

Method	Benefits	Drawbacks	Suggested Uses	Estimated Throughput
CPU Programmed I/O	<ul style="list-style-type: none"> • Simple Software • Least PL Resources • Simple PL Slaves 	<ul style="list-style-type: none"> • Lowest Throughput 	<ul style="list-style-type: none"> • Control Functions 	<25 MB/s
PS DMAC	<ul style="list-style-type: none"> • Least PL Resources • Medium Throughput • Multiple Channels • Simple PL Slaves 	<ul style="list-style-type: none"> • Somewhat complex DMA programming 	<ul style="list-style-type: none"> • Limited PL Resource DMAs 	600 MB/s
PL AXI_HP DMA	<ul style="list-style-type: none"> • Highest Throughput • Multiple Interfaces • Command/Data FIFOs 	<ul style="list-style-type: none"> • OCM/DDR access only • More complex PL Master design 	<ul style="list-style-type: none"> • High Performance DMA for large datasets 	1,200 MB/s (per interface)
PL AXI_ACP DMA	<ul style="list-style-type: none"> • Highest Throughput • Lowest Latency • Optional Cache Coherency 	<ul style="list-style-type: none"> • Large burst might cause cache thrashing • Shares CPU Interconnect bandwidth • More complex PL Master design 	<ul style="list-style-type: none"> • High Performance DMA for smaller, coherent datasets • Medium granularity CPU offload 	1,200 MB/s
PL AXI_GP DMA	<ul style="list-style-type: none"> • Medium Throughput 	<ul style="list-style-type: none"> • More complex PL Master design 	<ul style="list-style-type: none"> • PL to PS Control Functions • PS I/O Peripheral Access 	600 MB/s

Cortex-A9 CPU Using General Purpose Masters

The least intrusive method from a software perspective is to use the Cortex-A9 to move data between the PS and PL. Data flow is directly moved by a CPU, removing the need to handle events from a separate DMA. Access to the PL is provided through the two M_AXI_GP master ports, which each have a memory address range to originate PL AXI transactions. The PL design is also simplified because as little as a single AXI slave can be implemented to service the CPU requests.

Drawbacks of using a CPU to move data is that a sophisticated CPU is spending cycles performing simple data movement instead of complex control and computation tasks, and the limited throughput available. Transfer rates less than 25 MB/s are reasonable with this method.

See the *Zynq-7000 AP SoC Technical Reference Manual* (UG585) [Ref 26] for more information.

PS DMA Controller (DMAC) Using General Purpose Masters

The PS DMA controller (DMAC) provides a flexible DMA engine that can provide moderate levels of throughput with little PL logic resource usage. The DMAC resides in the PS and must be programmed through the DMA instructions residing in memory, typically prepared by a CPU. With support for up to eight channels, multiple DMA fabric cores can potentially be served in the single DMAC. However, the flexible programmable model might increase software complexity relative to CPU transfer or specialized PL DMA.

The DMAC interface to the PL is through the general purpose AXI master interfaces, whose 32-bit width along with the centralized DMA nature (a read and write transaction for each movement) of the DMAC to limit the DMAC from highest throughput. A peripheral request interface also allows PL slaves to provide status to the DMAC on buffer state, to prevent transactions involving a stalled PL peripheral from unnecessarily also stalling interconnect and DMAC bandwidth.

From the *Zynq-7000 AP SoC Technical Reference Manual* (UG585) [Ref 26], see this [link](#) to the “DMA Controller” chapter for more information on the DMAC controller, and this [link](#) to the “Interconnect” chapter for more information on the M_AXI_GP interfaces.

PL DMA Using AXI High-Performance (HP) Interface

The high-performance (S_AXI_HP) PL interfaces provide high-bandwidth PL slave interfaces to OCM and DDR memories. The AXI_HP ports are unable to access any other slaves.

With four, 64-bit wide interfaces, the AXI_HP provide the greatest aggregate interface bandwidth. The multiple interfaces also save PL resources by reducing the need to a PL AXI interconnect. Each AXI_HP contains control and data FIFOs to provide buffering of transactions for larger sets of bursts, making it ideal for workloads such as video frame buffering in DDR. This additional logic and arbitration does result in higher minimum latency than other interfaces.

The user IP logic residing in the PL generally consists of a low-speed control interface and higher performance burst interface. If control flow is orchestrated by the Cortex-A9 CPU, the general purpose M_AXI_GP port can be used for tasks such as configuring the memory addresses the user IP should access and transaction status.

Transaction status can also be conveyed using PL to PS interrupts. Higher performance devices connected to AXI_HP should be able to issue multiple outstanding transactions to take advantage of the AXI_HP FIFOs.

The PL design complexity of multiple AXI interfaces along with the associated PL utilization are the primary drawbacks of implementing a DMA engine in the PL for both S_AXI_HP and S_AXI_ACP interfaces.

See this [link](#) to the “Interconnect” chapter of the *Zynq-7000 AP SoC Technical Reference Manual* (UG585) [Ref 32] for more information on the AXI_HP interface.

PL DMA Using AXI ACP

The AXI ACP interface (`S_AXI_ACP`) provides a similar user IP topology as is in the high performance `S_AXI_HP` interfaces. Also 64 bits wide, the ACP also provides highest throughput capability for a single AXI interface.

The ACP differs from the HP performance ports due to its connectivity inside of the PS. The ACP connects to the snoop control unit (SCU) which is also connected to the CPU L1 and the L2 cache. This connectivity allows ACP transactions to interact with the cache subsystems, potentially decreasing total latency for data to be consumed by a CPU. These optionally cache-coherent operations can prevent the need to invalidate and flush cache lines. The ACP also has the lowest memory latency to memory of the PL interfaces. The connectivity of the ACP is similar to that of the CPUs.

The drawbacks from using the ACP besides those shared with the `S_AXI_HP` interfaces also stem from the locality to the cache and CPUs:

- Memory accesses through the ACP use the same interconnect paths as the APU, potentially decreasing CPU performance.
- Large, coherent ACP transfers can cause thrashing of the cache.

Consequently, ACP coherent transfers are best suited for less than the largest data-sets. The ACP low-latency access allows opportunity for algorithm acceleration of medium granularity.

For more information on `S_AXI_ACP`, see this [link](#) to the “Application Processing Unit” chapter of the *Zynq-7000 AP SoC Technical Reference Manual* (UG585) [Ref 26].

PL DMA Using General Purpose AXI Slave (GP)

While the general purpose AXI Slave (`S_AXI_GP`) has reasonably low latency to OCM and DDR, its narrow 32-bit interface limits its utility as a DMA interface. The two `S_AXI_GP` interfaces are more likely to be used for lower-performance control access to the PS memories, registers and peripherals.

More information on the `S_AXI_GP` interfaces can be found in at this [link](#) in the “Interconnect” chapter of the *Zynq-7000 AP SoC Technical Reference Manual* (UG585) [Ref 26].

Memory Management Unit (MMU)

AXI behavior of the Arm CPU is controlled by the MMU and cache settings, which is detailed in the “Memory Management Unit” chapter of the *Zynq-7000 AP SoC Technical Reference Manual* (UG585) [Ref 26].

The MMU in the ARM architecture involves both memory protection and address translation. The MMU works closely with the L1 and L2 memory systems in the process of translating virtual addresses to physical addresses. It also controls accesses to and from the external memory. MMU is responsible for checking of virtual address and ASID (address space identifier).

See the “Memory Management Unit” section in the *Zynq-7000 AP SoC Technical Reference Manual* (UG585) [Ref 32] for more information.

MicroBlaze Processor

This section contains an overview of the MicroBlaze™ processor features.

Overview

The MicroBlaze embedded processor soft core is a reduced instruction set computer (RISC) optimized for implementation in Xilinx Field Programmable Gate Arrays (FPGAs). The following figure shows a functional block diagram of the MicroBlaze core.

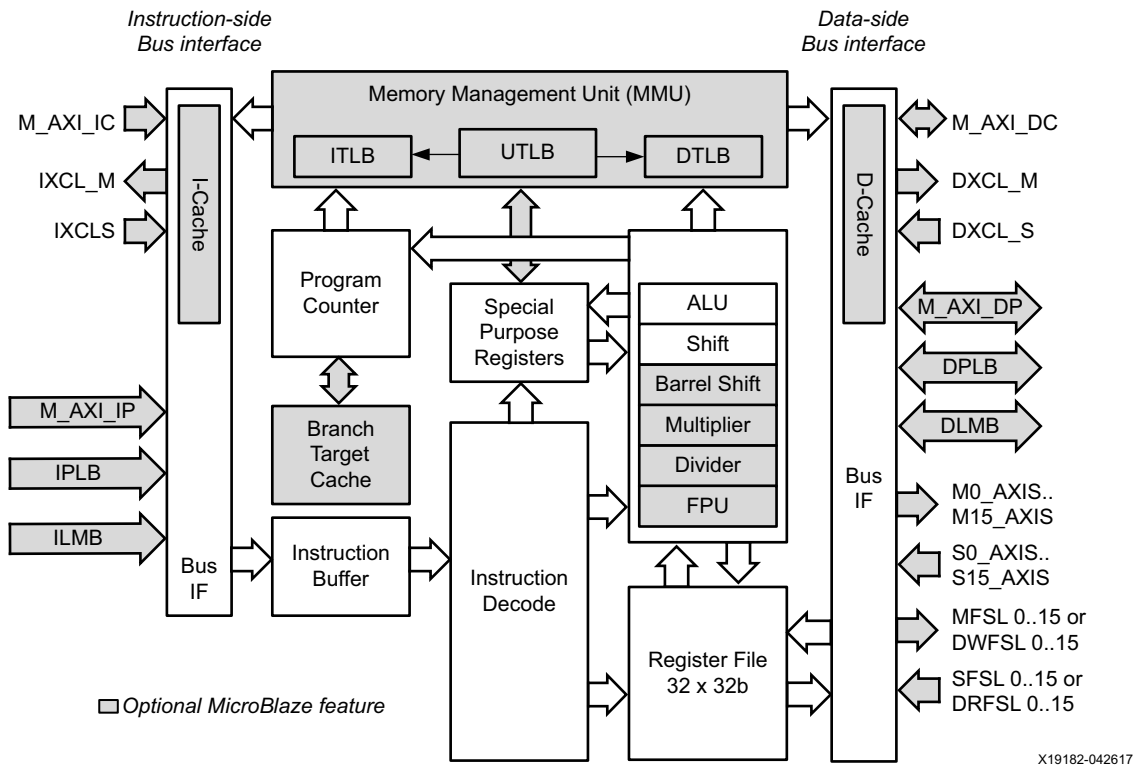

Figure 3-25: MicroBlaze Core Block Diagram

MicroBlaze Features

The MicroBlaze soft core processor is highly configurable, allowing you to select a specific set of features required by your design.

The fixed feature set of the processor includes:

- Thirty-two 32-bit general purpose registers
- 32-bit instruction word with three operands and two addressing modes
- 32-bit address bus
- Single issue pipeline

In addition to these fixed features, the MicroBlaze processor is parameterized to allow selective enabling of additional functionality. The following section provides an overview of the MicroBlaze configurable features by versions.

Configurable MicroBlaze Feature Overview

- Processor pipeline depth of 3/5
- Local Memory Bus (LMB) data side interface
- Local Memory Bus (LMB) instruction side interface
- Hardware barrel shifter
- Hardware divider
- Hardware debug logic
- Stream link interfaces (0-15 AXI)
- Machine status set and clear instructions
- 4 or 8-word cache line
- Hardware exception support
- Pattern compare instructions
- Floating point unit (FPU)
- Disable hardware multiplier⁽¹⁾
- Hardware debug readable ESR and EAR (Yes)
- Processor Version Register (PVR)
- Area or speed optimized
- Hardware multiplier 64-bit result
- LUT cache memory
- Floating point conversion and square root instructions

1. Used for saving DSP48E primitives.

- Memory Management Unit (MMU)
- Extended stream instructions
- Use Cache Interface for All I-Cache Memory Accesses
- Use Cache Interface for All D-Cache Memory Accesses
- Use Write-back Caching Policy for D-Cache
- Branch Target Cache (BTC)
- Streams for I-Cache
- Victim handling for I-Cache
- Victim handling for D-Cache
- AXI4 (M_AXI_DP) data side interface
- AXI4 (M_AXI_IP) instruction side interface
- AXI4 (M_AXI_DC) protocol for D-Cache
- AXI4 (M_AXI_IC) protocol for I-Cache
- AXI4 protocol for stream accesses
- Fault tolerant features
- Tool selectable endianness
- Force distributed RAM for cache tags
- Configurable cache data widths
- Count Leading Zeros instruction
- Memory Barrier instruction (Yes)
- Stack overflow and underflow detection
- Allow stream instructions in user mode
- Lockstep support
- Configurable use of FPGA primitives
- Low-latency interrupt mode
- Swap instructions
- Sleep mode and sleep instruction (Yes)
- Relocatable base vectors
- ACE (M_ACE_DC) protocol for D-Cache
- ACE (M_ACE_IC) protocol for I-Cache
- Extended debug: performance monitoring, program trace, non-intrusive profiling
- Reset mode: enter sleep or debug halt at reset
- Extended debug: external program trace

MicroBlaze Memory Architecture

MicroBlaze is implemented with a Harvard memory architecture; instruction and data accesses are done in separate address spaces. Each address space has a 32-bit range (that is, handles up to 4 GB of instructions and data memory respectively). MicroBlaze has limited support for 64-bit addressing using special extended address access registers. The instruction and data memory ranges can be made to overlap by mapping them both to the same physical memory. The latter is useful for debugging.

Both instruction and data interfaces of MicroBlaze are default 32 bits wide and use big Endian or little Endian, bit-reversed format, depending on the parameter `C_ENDIANNES`. MicroBlaze supports word, halfword, and byte accesses to data memory.

Data accesses must be aligned (word accesses must be on word boundaries, halfword on halfword boundaries), unless the processor is configured to support unaligned exceptions. All instruction accesses must be word aligned.

MicroBlaze pre-fetches instructions to improve performance, using the instruction pre-fetch buffer and (if enabled) instruction cache streams. To avoid attempts to pre-fetch instructions beyond the end of physical memory, which may cause an instruction bus error or a processor stall, instructions must not be located too close to the end of physical memory. The instruction pre-fetch buffer requires 16 bytes margin, and using instruction cache streams adds two additional cache lines (32 or 64 bytes).

MicroBlaze does not separate data accesses to I/O and memory (it uses memory mapped I/O). The processor has up to three interfaces for memory accesses:

- Local Memory Bus (LMB)
- AXI4 for peripheral access
- AXI4 or AXI Coherency Extension (ACE) for cache access



IMPORTANT: *The LMB memory address range must not overlap with AXI4 ranges.*

The `C_ENDIANNES` parameter is automatically set to little endian when using AXI4, but can be overridden by the user.

MicroBlaze Hardware AXI Exceptions

The following hardware exceptions can be encountered when using AXI protocol with MicroBlaze:

- **Stream Exception:** An AXI4-Stream exception is caused by executing a `get` or `getd` instruction with the `e` bit set to 1 when there is a control bit mismatch.
- **Instruction Bus Exception:** The instruction bus exception is caused by errors when reading data from memory.

- .. Instruction peripheral AXI4 interface (`M_AXI_IP`) exception is caused by an error response on `M_AXI_IP_RRESP`.
- .. Instruction cache AXI4 interface (`M_AXI_IC`) is caused by an error response on `M_AXI_IC_RRESP`. The exception can only occur when `C_ICACHE_ALWAYS_USED` is set to 1 and the cache is turned off, or if the MMU Inhibit Caching bit is set for the address. In all other cases the response is ignored.
- .. Instructions side local memory (ILMB) can only cause instruction bus exception when either an uncorrectable error occurs in the LMB memory, as indicated by the `IUE` signal, or `C_ECC_USE_CE_EXCEPTION` is set to 1 and a correctable error occurs in the LMB memory, as indicated by the `ICE` signal.
- **Illegal Opcode Exception:** The illegal opcode exception is caused by an instruction with an invalid major opcode (bits 0 through 5 of instruction).
 - Bits 6 through 31 of the instruction are not checked.
 - Optional processor instructions are detected as illegal if not enabled. If the optional feature `C_OPCODE_0x0_ILLEGAL` is enabled, an illegal opcode exception is also caused if the instruction is equal to `0x00000000`.
- **Data Bus Exception:** A data bus exception is caused by errors when reading data from memory or writing data to memory.
 - The data peripheral AXI4 interface (`M_AXI_DP`) exception is caused by an error response on `M_AXI_DP_RRESP` or `M_AXI_DP_BRESP`.
 - The data cache AXI4 interface (`M_AXI_DC`) exception is caused by:
 - An error response on `M_AXI_DC_RRESP` or `M_AXI_DC_BRESP`,
 - OKAY response on `M_AXI_DC_RRESP` in case of an exclusive access using `LWX`.

The exception can only occur when `C_DCACHE_ALWAYS_USED` is set to 1 and the cache is turned off, when an exclusive access using `LWX` or `SWX` is performed, or if the MMU Inhibit Caching bit is set for the address. In all other cases the response is ignored.

Using MicroBlaze AXI Instruction Cache

MicroBlaze can be used with an optional instruction cache for improved performance when executing code that resides outside the LMB address range. The `M_AXI_IC` instruction lets you cache over an AXI4 interface.

For every instruction fetched, the instruction cache detects if the instruction address belongs to the cacheable segment.

- If the address is non-cacheable, the cache controller ignores the instruction and lets the `M_AXI_IP` or LMB complete the request.

- If the address is cacheable, a lookup is performed on the tag memory to check if the requested address is currently cached. The lookup is successful if the word and line valid bits are set, and the tag address matches the instruction address tag segment.
- On a cache miss, the cache controller requests the new instruction over the instruction AXI4 interface (`M_AXI_IC`), and waits for the memory controller to return the associated cache line.
- `C_ICACHE_DATA_WIDTH` determines the bus data width, either 32 bits, an entire cache line (128 bits or 256 bits), or 512 bits.
- When `C_FAULT_TOLERANT` is set to 1, a cache miss also occurs if a parity error is detected in a tag or instruction Block RAM.
- The instruction cache issues burst accesses for the AXI4 interface when 32-bit data width is used, otherwise single accesses are used.

Using MicroBlaze AXI Data Cache

MicroBlaze can be used with an optional data cache for improved performance. The cached memory range must not include addresses in the LMB address range. The data cache has a caching over AXI4 interface (`M_AXI_DC`) feature.

The caching policy used by the MicroBlaze data cache, write-back or write-through, is determined by the parameter `C_DCACHE_USE_WRITEBACK`. When this parameter is set, a write-back protocol is implemented, otherwise write-through is implemented. However, when configured with an MMU (`C_USE_MMU > 1`, `C_AREA_OPTIMIZED = 0`, `C_DCACHE_USE_WRITEBACK = 1`), the caching policy in virtual mode is determined by the `W` storage attribute in the TLB entry, whereas write-back is used in real mode.

With the write-back protocol, a store to an address within the cacheable range always updates the cached data.

- If the target address word is not in the cache (that is, the access is a cache miss), and the location in the cache contains data that has not yet been written to memory (the cache location is dirty), the old data is written over the data AXI4 interface (`M_AXI_DC`) to external memory before updating the cache with the new data. If only a single word needs to be written, a single word write is used, otherwise a burst write is used.
- For byte or halfword stores, in case of a cache miss, the address is first requested over the data AXI4 interface, while a word store only updates the cache.

With the write-through protocol, a store to an address within the cacheable range generates an equivalent byte, halfword, or word write over the data AXI4 interface to external memory. The write also updates the cached data if the target address word is in the cache (that is, the write is a cache hit). A write cache-miss does not load the associated cache line into the cache.

When cache is enabled a load from an address within the cacheable range triggers a check to determine if the requested data is currently cached.

- On a cache hit, the requested data is retrieved from the cache.
- On a cache miss, the address is requested over the data AXI4 interface using a burst read, and the processor pipeline stalls until the cache line associated to the requested address is returned from the external memory controller.
- The parameter `C_DCACHE_DATA_WIDTH` determines the bus data width, either 32 bits, an entire cache line (128 bits or 256 bits), or 512 bits.
- When `C_FAULT_TOLERANT` is set to 1 and write-through protocol is used, a cache miss also occurs if a parity error is detected in the tag or data Block RAM.



IMPORTANT: The DCE bit in the MSR controls whether or not the cache is enabled. When disabling caches the user must ensure that all the prior writes within the cacheable range have been completed in external memory before reading back over `M_AXI_DP`. This can be done by writing to a semaphore immediately before turning off caches, and then in a loop poll until it has been written. The contents of the cache are preserved when the cache is disabled.

The following table summarizes the access types of accesses issued by the data cache AXI4 interface.

Table 3-5: Data Cache Interface Accesses

Policy	State	Direction	Access Type
Write-through	Cache Enabled	Read	Burst for 32-bit interface non-exclusive access and exclusive access with ACE enabled, single access otherwise.
		Write	Single access.
	Cache Disabled	Read	Burst for 32-bit interface exclusive access with ACE enabled, single access otherwise.
		Write	Single access.
Write-back	Cache Enabled	Read	Burst for 32-bit interface, single access otherwise.
		Write	Burst for 32-bit interface cache lines with more than one valid word, a single access otherwise.
	Cache Disabled	Read	Burst for 32-bit interface non-exclusive access, discarding all but the desired data, a single access otherwise.
		Write	Single access.

Using Victim Cache

The victim cache is enabled by setting the parameter `C_DCACHE_VICTIMS` to 2, 4 or 8. This defines the number of cache lines that can be stored in the victim cache. Whenever a complete cache line is evicted from the cache, it is saved in the victim cache.

By saving the most recent lines they can be fetched much faster, should the processor request them, thereby improving performance. If the victim cache is not used, all evicted cache lines must be read from memory again when they are needed.

With the AXI4 interface, `C_DCACHE_DATA_WIDTH` determines the amount of data transferred from/to the victim cache each clock cycle, either 32 bits or an entire cache line.

Note: To be able to use the victim cache, write-back must be enabled and area optimization must not be enabled.

MicroBlaze Stream Link Interfaces

MicroBlaze can be configured with up to 16 AXI4-Stream interfaces, each consisting of one input and one output port. The channels are dedicated uni-directional point-to-point data streaming interfaces.

The interfaces on MicroBlaze are 32 bits wide. A separate bit indicates whether the sent/received word is of control or data type.

- The `get` instruction in the MicroBlaze ISA transfers information from a port to a general purpose register.
- The `put` instruction transfers data in the opposite direction.
- Both instructions are available as follows: blocking data, non-blocking data, blocking control, and non-blocking control. For a detailed description of the `get` and `put` instructions, see this [link](#) to the “MicroBlaze Instruction Set Architecture” chapter in the *MicroBlaze Processor Reference Guide* (UG984) [Ref 37].

AXI Feature Adoption in Xilinx Devices

Introduction

This chapter describes specific features from the AXI standard features used in Xilinx® IP to familiarize you as an IP designer with various AXI-related design and integration choices.

Memory-Mapped IP Feature Adoption and Support

Xilinx has implemented and is supporting a rich feature set from AXI4 and AXI4-Lite to facilitate interoperability among memory-mapped IP from Xilinx developers, individual users, and third-party partners.

The following table lists the key aspects of Xilinx AXI4 and AXI4-Lite adoption, and the level to which Xilinx IP has support for, and implemented features of the AXI4 specification.

Table 4-1: Xilinx AXI4 and AXI4-Lite Feature Adoption and Support

AXI Feature	Xilinx IP Support
READY/VALID Handshake	Full forward and reverse direction flow control of AXI protocol-defined READY/VALID handshake.
Transfer Length	AXI4 memory-mapped burst lengths of: <ul style="list-style-type: none"> · 1 to 256 beats for incrementing bursts · 1 to 16 beats for wrap bursts Fixed bursts should not be used with Xilinx IP. Conversions of FIXED bursts through AXI Interconnect infrastructure could have sub-optimal performance.
Transfer Size / Data Width	IP can be defined with native data widths of 32, 64, 128, 256, 512, and 1024 bits wide. For AXI4-Lite, the supported data width is 32 or 64 bits only, but 32-bits is recommended to minimize resource utilization. The use of AXI4 narrow bursts is supported but is not recommended. Use of narrow bursts can decrease system performance and increase system size. Where Xilinx IP of different widths need to communicate with each other, the AXI Interconnect provides data width conversion features.
Read/Write only	The use of read/write, read-only, or write-only interfaces. Many IP, including the AXI Interconnect, perform logic optimizations when an interface is configured to be Read-only or Write-only.

Table 4-1: Xilinx AXI4 and AXI4-Lite Feature Adoption and Support (Cont'd)

AXI Feature	Xilinx IP Support
AXI3 versus. AXI4	<p>Designed to support AXI4 natively. Where AXI3 interoperability is required, the AXI Interconnect contains the necessary conversion logic to allow AXI3 and AXI4 devices to connect.</p> <p>AXI3 write interleaving is <i>not</i> supported and should not be used with Xilinx IP.</p> <p>Note: The AXI3 write Interleaving feature was removed from the AXI4 specification.</p>
Lock / Exclusive Access	<p>No support for locked transfers.</p> <p>Xilinx infrastructure IP can pass exclusive access transactions across a system, but Xilinx IP does not support the exclusive access feature. All exclusive access requests result in "OK" responses.</p>
Protection/Cache Bits	<p>Infrastructure IP passes protection and cache bits across a system, but Endpoint IP generally do not contain support for dynamic protection or cache bits.</p> <ul style="list-style-type: none"> · Protections bits should be constant at 000 signifying a constantly secure transaction type. · Cache bits should generally be constant at 0011 signifying a bufferable and modifiable transaction. <p>This provides greater flexibility in the infrastructure IP to transport and modify transactions passing through the system for greater performance.</p>
Quality of Service (QoS) Bits	<p>Infrastructure IP passes QoS bits across a system.</p> <p>Endpoint IP generally ignores the QoS bits.</p>
REGION Bits	<p>Design of Endpoint slave IP to rely on REGION bits is discouraged because the computation of REGION bits and their mapping to address decoder ranges can be difficult to predict and maintain, especially across cascaded crossbars. The AXI interconnect generates REGION bits based upon the Base/High address decoder ranges defined in the address map for the AXI interconnect.</p> <p>Xilinx infrastructure IP, such as register slices, pass REGION bits across a system. However, AXI Master Endpoint IP do not generate REGION bits, which impacts point-to-point connections to slaves that rely on REGION bits.</p>
User Bits	<p>Infrastructure IP passes user bits across a system, except across width converters, but Endpoint IP generally ignores user bits.</p> <p>The use of user bits is discouraged in general purpose IP due to interoperability concerns, and because width conversion does not propagate user bits.</p>
Reset	<p>Xilinx IP generally deasserts all VALID and READY outputs within eight cycles of reset, and have a reset pulse width requirement of 16 cycles or greater.</p> <p>Holding AXI ARESETN asserted for 16 cycles of the slowest AXI clock is generally a sufficient reset pulse width for Xilinx IP.</p> <p>DSP IP has a requirement of 2 cycles for ARESETN on the AXI4-Stream interface.</p> <p>Some IP such as SmartConnect have support for optional reset inputs. These IP can be configured to only be reset with FPGA configuration and omit their reset input port to reduce logic resources and reset net congestion. IP without a reset input must still start up with READY/VALID deasserted until they are ready to accept their first AXI transaction.</p>
Low Power Interface	<p>Not Supported. The optional AXI low power interfaces, CSYSREQ, CSYSACK, and CACTIVE are not present on IP interfaces.</p>

AXI4-Stream Adoption and Support

To facilitate interoperability, Xilinx IP adopts a consistent set of AXI4-Stream protocol usage guidelines. This section provides an overview of the adoption of AXI4-Stream signals, numerical data type representation, and AXI4-Stream protocol usage across DSP, Wireless, and Video IP. For more information on how to construct systems by configuring your AXI4-Stream-based IP designs for interoperability, see *AXI4-Stream Infrastructure IP Suite: Product Guide for Vivado Design Suite* (PG085) [Ref 14].

AXI4-Stream Signals

The following lists the AXI4-Stream signals, status, and notes on usage. The AXI4-Stream signals use the following parameters to define the signal widths:

- n = Data bus width in bytes.
- i = TID width. Recommended maximum is 8-bits.
- d = TDEST width. Recommended maximum is 4-bits.
- u = TUSER width. Recommended number of bits is an integer multiple of the width of the interface in bytes.

Numerical Data in an AXI4-Stream

An AXI4-Stream channel is a method of transferring data from a master to a slave.



IMPORTANT: *To enable interoperability, both the master and slave must use the same, correct interpretation of those bits.*

In Xilinx IP, streaming interfaces are frequently used to transfer numerical data representing sampled physical quantities (for example: video pixel data, audio data, and signal processing data). Interoperability support requires a consistent interpretation of numerical data.



IMPORTANT: *Numerical data streams in Xilinx IP are defined in terms of logical and physical views. This is especially important to understand in DSP applications where information can be transferred essentially as data structures.*

- The logical view describes the application-specific organization of the data.
- The physical view describes how the logical view is mapped to bits and the underlying AXI4-Stream signals.

Simple vectors of values represent numerical data at the logical level. Individual values can be real or complex quantities depending on the application. Similarly the number of elements in the vector are application-specific.

At the physical level, the logical view is mapped to physical wires of the interface. Logical values are represented physically by a fundamental base unit of bit width N , where N is application-specific.

In general:

- N bits are interpreted as a fixed point quantity, but floating point quantities are also permitted.
- Real values are represented using a single base unit.
- Complex values are represented as a pair of base units signifying the real component followed by the imaginary component.

To aid interoperability, all logical values within a stream are represented using base units of identical bit width.

Before mapping to the AXI4-Stream signal, `TDATA`, the N bits of each base unit are rounded up to a whole number of bytes. As examples:

- A base unit with $N=12$ is packed into 16 bits of `TDATA`.
- A base unit with $N=20$ is packed into 24 bits of `TDATA`.

The AXI4-Stream protocol requires that `TDATA` ports of the IP have a width in multiples of 8. It is a specification violation to define an AXI4-Stream IP with a `TDATA` port width that is not a multiple of 8, therefore, it is a requirement to round up `TDATA` widths to byte multiples. This simplifies interfacing with memory-orientated systems, and also allows the use of AXI infrastructure IP, such as the AXI Interconnect, to perform upsizing and downsizing.

By convention, the additional packing bits are ignored at the input to a slave; they therefore use no additional resources and are removed by the backend tools. To simplify diagnostics, masters drive the unused bits in a representative manner, as follows:

- Unsigned quantities are zero-extended (the unused bits are zero).
- Signed quantities are sign-extended (the unused bits are copies of the sign bit).

The width of `TDATA` can allow multiple base units to be transferred in parallel in the same cycle. For example, if the base unit is packed into 16 bits and `TDATA` signal width was 64 bits, four base units could be transferred in parallel, corresponding to four scalar values or two complex values. Base units forming the logical vector are mapped first spatially (across `TDATA`) and then temporally (across consecutive transfers of `TDATA`).

Deciding whether multiple sub-fields of data (that are not byte multiples) should be concatenated together before or after alignment to byte boundaries is generally determined by considering how *atomic* is the information. Atomic information is data that can be interpreted on its own whereas non-atomic information is incomplete for the purpose of interpreting the data.

For example, atomic data can consist of all the bits of information in a floating point number. However, the exponent bits in the floating point number alone would not be atomic.

When packing information into TDATA, generally non-atomic bits of data are concatenated together (regardless of bit width) until they form atomic units. The atomic units are then aligned to byte boundaries using pad bits where necessary.

Real Scalar Data Example

A stream of scalar values can use two equally valid uses of the optional TLAST signal. This is illustrated in the following example. Consider a numerical stream with characteristics of the following values:

Table 4-2: Numerical Stream and Value

Numerical Stream	Value
Logical type	Unsigned Real
Logical vector length	1 (for example, scalar value)
Physical base unit	12-bit fixed point
Physical base unit packed width	16 bits
Physical TDATA width	16 bits

This would be represented as an AXI4-Stream, as shown in the following figure.

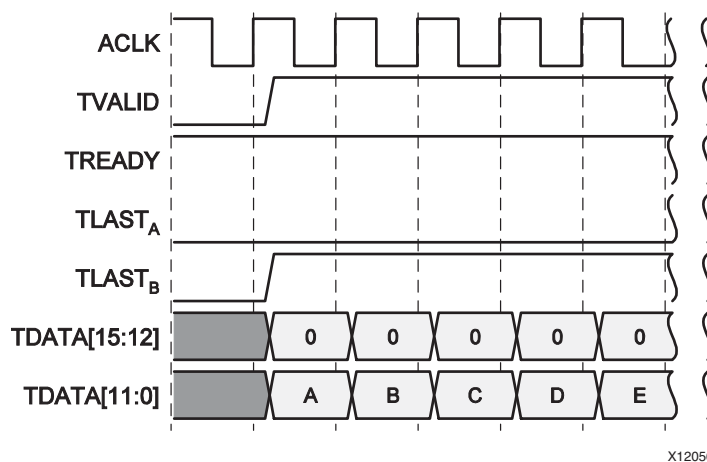

Figure 4-1: Real Scalar (Unsigned) Data Example in an AXI4-Stream

Scalar values can be considered as not packetized at all, in which case TLAST can legitimately be driven active-Low (TLAST_A). Because TLAST is optional, it could be removed entirely from the channel also.

Alternatively, scalar values can also be considered as vectors of unity length, in which case TLAST should be driven active-High (TLAST_B). Because the value type is unsigned, the unused packing bits are driven 0 (zero extended).

Similarly, for signed data the unused packing bits are driven with the sign bits (sign-extended), as shown in the following figure.

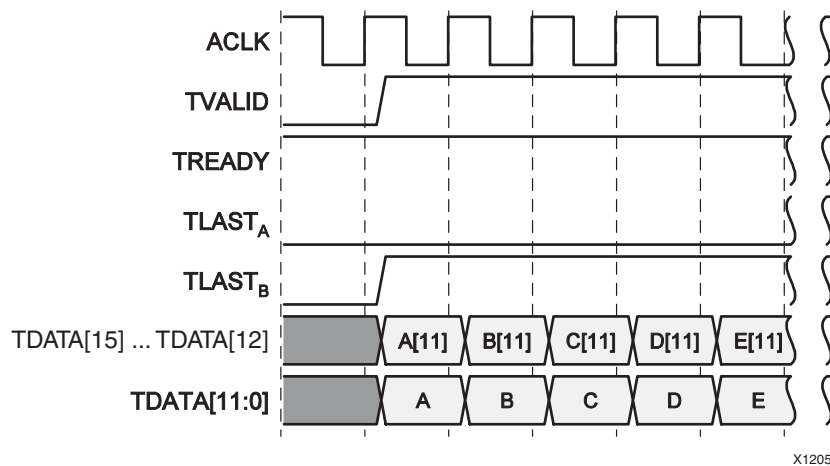

Figure 4-2: Alternative (Sign-Extended) Scalar Value Example

Complex Scalar Data Example

Consider a numerical stream with the following characteristics:

Table 4-3: Numerical Stream and Characteristic

Numerical Stream	Characteristic
Logical type	Signed Complex
Logical vector length	1 (for example: scalar)
Physical base unit	12 bit fixed point
Physical base unit packed width	16 bits
Physical TDATA width	16 bits

This would be represented as an AXI4-Stream, as shown in the following figure:

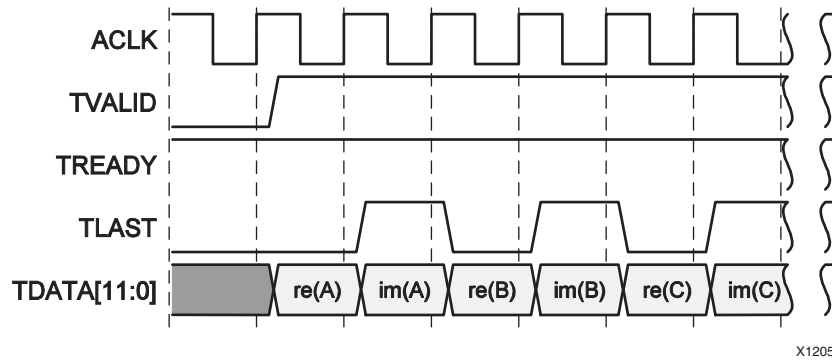

Figure 4-3: Complex Scalar Data Example in AXI4-Stream

Where re(X) and im(X) represent the real and imaginary components of X respectively.

Note: For simplicity, sign extension into TDATA[15:12] is not illustrated here. A complex value is transferred every two clock cycles.

The same data can be similarly represented on a channel with a TDATA signal width of 32 bits. A wider bus allows a complex value to be transferred every clock cycle, as shown in the following figure.

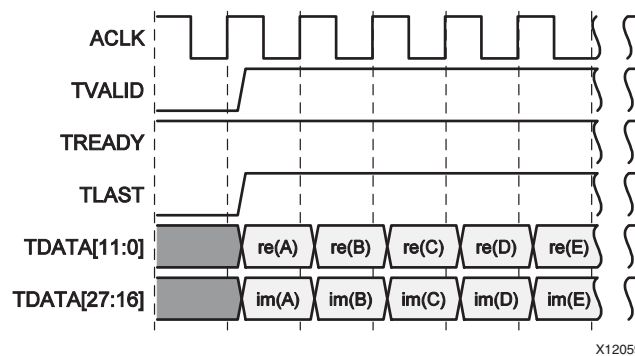

Figure 4-4: Complex Scalar Example with 32-Bit TDATA Signal

The two representations in the preceding figures of the same data (serial and parallel) show that data representation can be tailored to specific system requirements.

For example, a:

- High throughput processing engine such as a Fast Fourier Transform (FFT) might favor the parallel form
- MAC-based Finite Impulse Response (FIR) might favor the serial form, thus enabling Time Division Multiplexing (TDM) data path sharing

To enable interoperability of sub-systems with differing representation, you need a conversion mechanism. This representation was chosen to enable simple conversions using a standard AXI infrastructure IP:

- Use an AXI4-Stream-based upsizer to convert the serial form to the parallel form.
- Use an AXI4-Stream-based downsizer to convert the parallel form to the serial form.

You can implement an AXI4-Stream-based upsizer or downsizer by using the width conversion feature of the AXI4-Stream Interconnect. For more information see the *AXI4-Stream Interconnect page* [Ref 4].

Vector Data Example

Consider the example of a numerical stream with the following characteristics:

Table 4-4: Numerical Stream and Characteristic

Numerical Stream	Characteristics
Logical type	Signed Complex
Logical vector length	4
Physical base unit	12 bit fixed point
Physical base unit packed width	16 bits
Physical TDATA width	16 bits

The following figure shows the AXI4-Stream representation of that numerical stream:

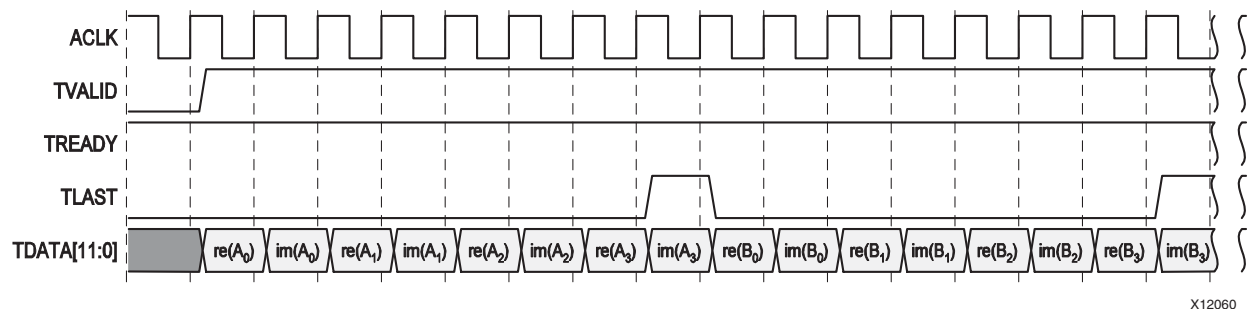

Figure 4-5: Numerical Stream Example

X12060

As for the scalar case, the same data can be represented on a channel with TDATA width of 32 bits, as shown in the following figure.

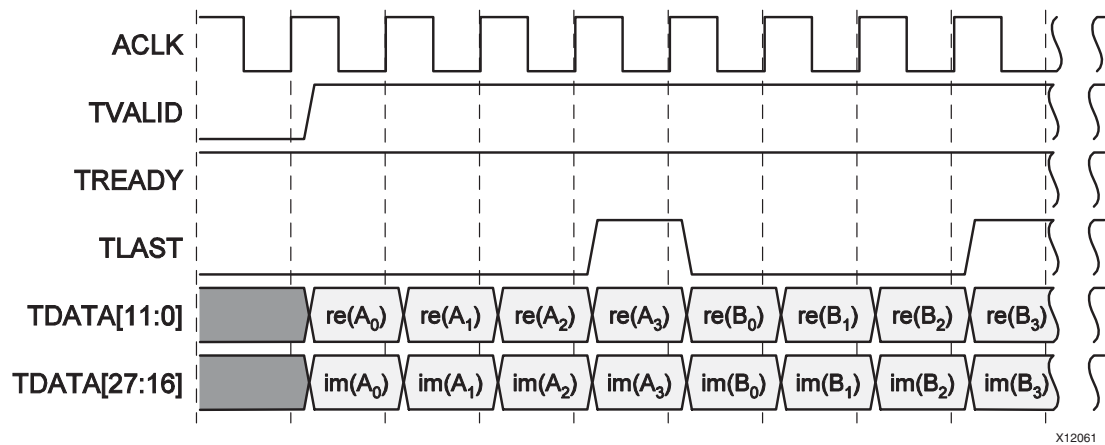

Figure 4-6: AXI4-Stream Scalar Example

The degree of parallelism can be increased further for a channel with TDATA width of 64 bits, as shown in the following figure.

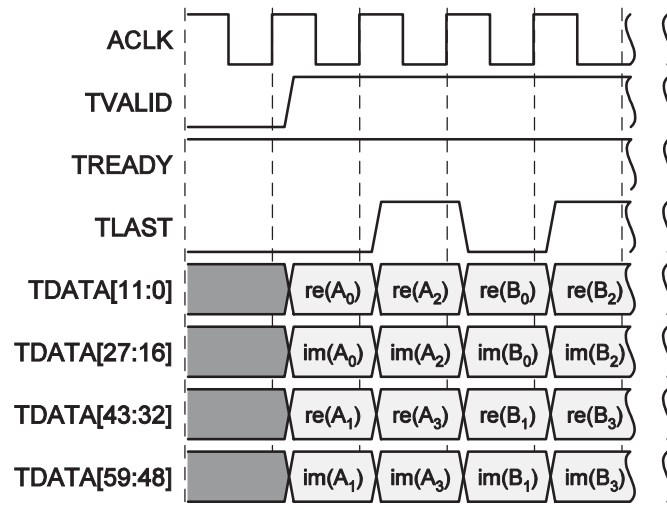

Figure 4-7: TDATA Example with 64-Bits

Full parallelism can be achieved with TDATA width of 128 bits, as shown in the following figure.

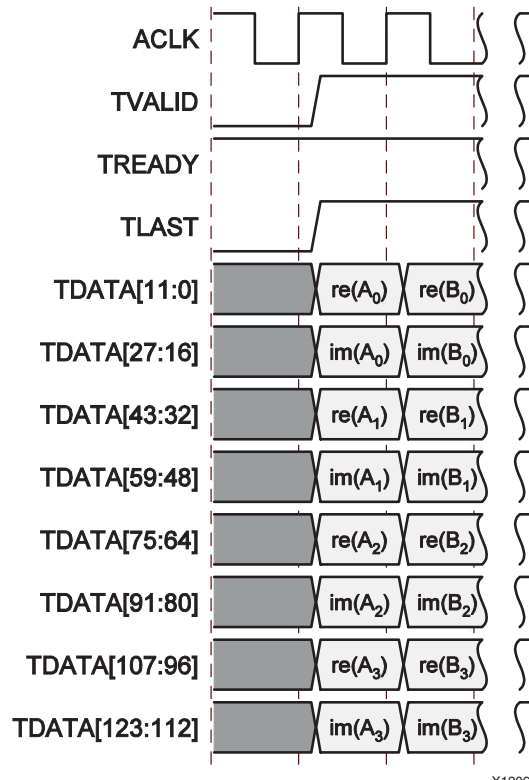

Figure 4-8: 128 Bit TDATA Example

As shown in the preceding figures, for the scalar data there are multiple representations that you can customize to the application.

Similarly, AXI4-Stream upsize and downsize blocks can be used for conversion.

Scalar values can be considered as not packetized at all, in which case TLAST can legitimately be driven active-Low (TLAST_A). Because TLAST is optional, it could be removed entirely from the channel also.

Alternatively, scalar values can also be considered as vectors of unity length, in which case TLAST should be driven active-High (TLAST_B). Because the value type is unsigned, the unused packing bits are driven 0 (zero extended).

Similarly, for signed data the unused packing bits are driven with the sign bits (sign-extended), Packets and NULL Bytes

The AXI4-Stream protocol lets you specify packet boundaries using the optional TLAST signal.

In many situations this is sufficient; however, by definition, the TLAST signal indicates the size of the data at the end of the packet, while many IP require packet size at the beginning.

In such situations, where packet size is specified at the beginning, the IP typically requires an alternative mechanism to provide that packet-size information. Streaming slave channels can therefore be divided into three categories:

- Slaves that do not require the interpretation of packet boundaries.

There are slave channels that do not have any concept of packet boundaries, or when the size of packets do not affect the processing operation performed by the core. Frequently, IP of this type provides a pass-through mechanism to allow `TLAST` to propagate from input to output with equal latency to the data.

- Slaves that require the `TLAST` signal to identify packet boundaries.

These slaves channels are inherently packet-orientated, and can use `TLAST` as a packet size indicator. For example, a Cyclic Redundancy Check (CRC) core can calculate the CRC while data is being transferred, and upon detecting the `TLAST` signal, can verify that the CRC is correct.

- Slaves that do not require `TLAST` to identify packet boundaries.

Some slave channels have an internal expectation of what size packets are required. For example, an FFT input packet size is always the same as the transform size. In these cases, `TLAST` would represent redundant information and also potentially introduce ambiguity into packet sizing (for example: what should an N -point FFT do when presented with an $N-1$ sample input packet.)

To prevent this ambiguity, many Xilinx IP cores are designed to ignore `TLAST` on slave channels, and to use the explicit packet sizing information available to them.

In these situations the core uses the required number of AXI transfers it is expecting regardless of `TLAST`. This typically greatly aides interoperability as the master and slave are not required to agree on when `TLAST` must be asserted.

For example, consider an FIR followed by an N -point FFT. The FIR is a stream-based core and cannot natively generate a stream with `TLAST` asserted every N transfers.

If the FFT is designed to ignore the incoming `TLAST` this is not an issue, and the system functions as expected. However, if the FFT did require `TLAST`, an intermediate “re-framing” core would be required to introduce the required signalling.

- For Packetized Data, `TKEEP` might be necessary to signal packet remainders.

When the `TDATA` width is greater than the atomic size (minimum data granularity) of the stream, a remainder is possible because there might not be enough data bytes to fill an entire data beat. The only supported use of deasserted `TKEEP` for Xilinx endpoint IP is for packet remainder signaling. Deasserted `TKEEP` bits (which is called “Null Bytes” in the *AXI4-Stream Protocol Specification [Ref 1]*) are only present in a data beat with `TLAST` asserted.

For non-packetized continuous streams or packetized streams where the data width is the same size or smaller than the atomic size of data, there is no need for `TKEEP`. This generally follows the “Continuous Aligned Stream” model described in the AXI4-Stream protocol.

The AXI4-Stream protocol describes the usage for `TKEEP` to encode trailing null bytes to preserve packet lengths after size conversion, especially after upsizing an odd length packet. This usage of `TKEEP` essentially encodes the remainder bytes after the end of a packet which is an artifact of upsizing a packet beyond the atomic size of the data.

Xilinx AXI master IP do not generate any packets that have trailing transfers with all `TKEEP` bits deasserted. Xilinx AXI masters with a `TKEEP` output port must drive them correctly at all times. This implies driving all `TKEEP` bits high when `TLAST` is deasserted and using `TKEEP` to signal the remainder when `TLAST` is asserted.

Xilinx infrastructure IP passes through `TKEEP` values and attempts to process them in a protocol-compliant manner.

This guideline maximizes compatibility and throughput because Xilinx IP does not originate packets containing trailing transfers with all `TKEEP` bits deasserted. Any deasserted `TKEEP` bits must be associated with `TLAST = 1` in the same data beat to signal the byte location of the last data byte in the packet.

Xilinx AXI slave IP are generally not designed to be tolerant of receiving packets that have trailing transfers with all `TKEEP` bits deasserted. Slave IP that have `TKEEP` inputs can be designed to internally only sample `TKEEP` with `TLAST` is asserted to determine the packet remainder bytes. In general if Xilinx IP are used in the system with other IP designed for “Continuous Aligned Streams” as described in the *AXI4-Stream Protocol Specification* [Ref 1], trailing transfers with all `TKEEP` bits deasserted not occur.

All streams entering into a system of Xilinx IP must be fully packed upon entry in the system (no leading or intermediate null bytes) in which case arbitrary size conversion will only introduce `TKEEP` for packet remainder encoding and will not result in data beats where all `TKEEP` bits are deasserted.

Sideband Signals

- The AXI4-Stream interface protocol allows passing sideband signals using the `TUSER` bus.

From an interoperability perspective, using `TUSER` on an AXI4-Stream channel is an issue because both Master and Slave must now not only have the same interpretation of `TDATA` and `TUSER`.

Generally, Xilinx IP uses the `TUSER` field only to augment the `TDATA` field with information that could prove useful, but ultimately can be ignored. Ignoring `TUSER` could result in some loss of information, but the `TDATA` field still has some meaning.

An FFT core implementation can use a `TUSER` output to indicate block exponents to apply to the `TDATA` bus. If `TUSER` is ignored, the exponent scaling factor is lost, but `TDATA` still contains unscaled transform data.

Events

- An event signal is a single wire interface used by a core to indicate that some specific condition exists (for example: an input parameter is invalid, a buffer is empty or nearly full, or the core is waiting on some additional information).

Events are asserted while the condition is present, and are deasserted once the condition passes, and exhibit no latching behavior. Depending on the core and how it is used in a system, an asserted event might indicate an error, a warning, or information. Event signals can be viewed as AXI4-Stream channels with an `VALID` signal only, without any optional signals. Event signals can also be considered out-of-band information and treated like generic flags, interrupts, or status signals.

Events can be used in many different ways:

- **Ignored:** Unless explicitly stated otherwise, a system can ignore all event conditions.
In general, a core continues to operate while an event is asserted, although potentially in some degraded manner.
- **As Interrupts or GPIOs:** An event signal might be connected to a processor using a suitable interrupt controller or general purpose I/O controller. System software is then free to respond to events as necessary.
- **As Simulation Diagnostic:** Events can be useful during hardware simulation. They can indicate interoperability issues between masters and slaves, or indicate misinterpretation of how subsystems interact.
- **As Hardware Diagnostic:** Similarly, events can be useful during hardware diagnostic. You can route events signals to diagnostic LED or test points, or connect them to the Vivado Lab Edition

As a system moves from development through integration to release, confidence in its operation is gained; as confidence increases, the need for events diminishes.

During development simulations, events can be actively monitored to ensure a system is operating as expected. During hardware integration, events might be monitored only if unexpected behavior occurs, while in a fully-tested system, it might be reasonable to ignore events.

Note: Events signals are asserted when the core detects the condition described by the event; depending on internal core latency and buffering, this could be an indeterminate time after the inputs that caused the event are presented to the core.

TLAST Events

- Some slave channels do not require a TLAST signal to indicate packet boundaries. In such cases, the core has a pair of events to indicate any discrepancy between the presented TLAST and the internal concept of packet boundaries:
 - **Missing TLAST:** TLAST is not asserted when expected by the core.
 - **Unexpected TLAST:** TLAST is asserted when not expected by the core.

Depending on the system design these events might or might not indicate potential problems.

Consider an FFT core used as a coprocessor to a CPU where data is streamed to the core using a packet-orientated DMA engine.

The DMA engine can be configured to send a contiguous region of memory of a given length to the FFT core, and to correctly assert TLAST at the end of the packet. The system software can elect to use this coprocessor in a number of ways:

- **Single Transforms:** The simplest mode of operation is for the FFT core and the DMA engine to operate in a lockstep manner. If the FFT core is configured to perform an N point transform, then the DMA engine should be configured to provide packets of N complex samples.

If a software or hardware bug is introduced that breaks this relationship, the FFT core detects TLAST mismatches and asserts the appropriate event. In this case that is indicating error conditions.

- **Grouped Transforms:** Typically, for each packet transferred by the DMA engine, a descriptor is required containing start address, length, and flags; generating descriptors and sending them to the engine requires effort from the host CPU. If the size of transform is short and the number of transforms is high, the overhead of descriptor management might begin to overcome the advantage of offloading processing to the FFT core.

One solution is for the CPU to group transforms into a single DMA operation.

If the FFT core is configured for 32-point transforms, the CPU could group 64 individual transforms into a single DMA operation. The DMA engine generates a single 2048 sample packet containing data for the 64 transforms; however, as the DMA engine is only sending a single packet, only the data for the last transform has a correctly placed TLAST. The FFT core then reports 63 individual 'missing TLAST' events for the grouped operation. In this case the events are entirely expected and do not indicate an error condition.

In the example case, the 'unexpected TLAST' event should not assert during normal operation. At no point should a DMA transfer occur where TLAST does not align with the end of an FFT transform.

However, as for the described single transform example case, a software or hardware error could result in this event being asserted. If the transform size is incorrectly changed in the middle of the grouped packet, an error occurs.

- **Streaming Transforms:** For large transforms it might be difficult to arrange to hold the entire input packet in a single contiguous region of memory.

In such cases it might be necessary to send data to the FFT core using multiple smaller DMA transfers, each completing with a `TLAST` signal.

Depending on how the CPU manages DMA transfers, it is possible that the `TLAST` signal never aligns correctly with the internal concept of packet boundaries within the FFT core.

The FFT core would therefore assert both 'missing `TLAST`' and 'unexpected `TLAST`' events as appropriate while the data is transferring. In this example case, both events are entirely expected, and do not indicate an error condition.

DSP and Wireless IP: AXI Feature Adoption

An individual AXI4-Stream slave channel can be categorized as either a blocking or a non-blocking channel.

A slave channel is blocking when some operation of the core is inhibited until a transaction occurs on that channel.

For example, consider an FFT core that features two slave channels; a data channel and a control channel. The data channel transfers input data, and the control channel transfers control packets indicating how the input data should be processed (like transform size).

The control channel can be designed to be either blocking or non-blocking:

- A blocking case performs a transform only when both a control packet and a data packet are presented to the core.
- A non-blocking case performs a transform with just a data packet, with the core reusing previous control information.

There are numerous trade-offs related to the use of blocking versus non-blocking interfaces. The following table lists the trade-offs:

Table 4-5: Blocking Versus Non-Blocking Interfaces

Feature	Blocking	Non-blocking
Synchronization	Automatic Core operates on transactions; for example, one control packet and one input data packet produces one output data packet.	Not automatic System designer must ensure that control information arrives at the core before the data to which it applies.
Signaling Overhead	Small Control information must be transferred even if it does not change.	Minimized Control information need be transferred only if it changes.
Connectivity	Simple Data flows through a system of blocking cores as and when required; automatic synchronization ensures that control and data remain in step.	Complex System designer must manage the flow of data and control flow though a system of non-blocking cores.
Resource Overhead	Small Cores typically require small additional buffers and state machines to provide blocking behavior.	None Cores typically require no additional resources to provide non-blocking behavior.

Generally, the simplicity of using blocking channels outweighs the penalties.

Note: The distinction between blocking and non-blocking behavior is a characteristic of how a core uses data and control presented to it; it does not necessarily have a direct influence on how a core drives `READY` on its slave channels. For example, a core might feature internal buffers on slave channels, in which case `READY` is asserted while the buffer has free space.

Note: In many cases, DSP and Wireless IP have base units that do not usually fall on the 8-bit (Byte) boundaries. See [Numerical Data in an AXI4-Stream](#) for information on how to handle data that does not fall on byte boundaries.

Video IP: AXI Feature Adoption

For comprehensive information about Video IP Protocol, see the *Video IP Protocol and Design Guide* (UG934) [\[Ref 27\]](#).

See *Partial Reconfiguration of a Hardware Accelerator with Vivado Design Suite* (XAPP1231) [\[Ref 47\]](#) for a design example using Partial Reconfiguration, and AXI Interconnects to display graphics in a variety of modes.

In the video domain, there are established signals that are used in many standards to transmit data across video communication channels. These signals include video data and synchronization for proper communication and flow control.

Typically, video signals are propagated using several processing cores and frame buffers along which video resolution, frame rate, and formatting (such as interlaced to de-interlaced) can change.

Processing cores can:

- Process a single stream (the Xilinx Image Statistics core)
- Process and generate a single stream (most Xilinx Image Processing cores)
- Process multiple streams to generate a single stream (the Xilinx On Screen Display (OSD) core)
- Process multiple streams to generate multiple streams (the Xilinx Motion Adaptive Noise Reduction (MANR) core)

Video data enters the system through the input interface and exits the system through a similar interface, which is, in many cases, connected to a monitor for display of the processed video sequence. In a complex video system, the IP cores provide a register interface that is used for setup and control by a central managing microprocessor. This type of system is supported by Xilinx design tools such as the Vivado IDE embedded tools using the Zynq®-7000 AP SoC processor or MicroBlaze™ processor.

Xilinx Video IP cores are used in a variety of video and imaging applications and a wide range of markets, from Industrial, Scientific, and Medical (ISM), automotive and customer electronics to professional broadcast markets. The interface and protocol addresses the needs of multiple application domains.

IP using the AXI4-Stream Video Protocol provides a simple, versatile, high-performance point-to-point communication interface between video IP cores that is easy for video designers to use.

Using the industry standard AXI interface allows video cores to connect to embedded processors and infrastructure IP.

Based upon a well-defined, standard interface and protocol, video and system designers can leverage advanced Xilinx tools to connect video IP and to build video systems.

The following subsections provide the requirements, standards, recommendations, and guidelines for Xilinx Video IP design to adapt AXI4-Stream interfaces, and harmonize AXI4-Stream based Video IP development with AXI4-Stream based DSP IP, infrastructure IP, and tools development.

The subsections also provide the details for defining AXI4-Stream based Video IP interfaces, and describes the signals and protocols for transmitting video using the AXI4-Stream interface, its applicability to a wide range of video systems, and usage guidelines for interoperability.

This subsection also defines the:

- Set of AXI4-Stream signals used for video data exchange between IP cores
- Protocol of transmitting video frames using the AXI4-Stream interface
- List of supported data, such as RGB, 420 YCC, and the mapping of data to the TDATA bus (see [Table 4-9](#)).

Video systems follow the general pipelined processing chain, shown in the following figure.

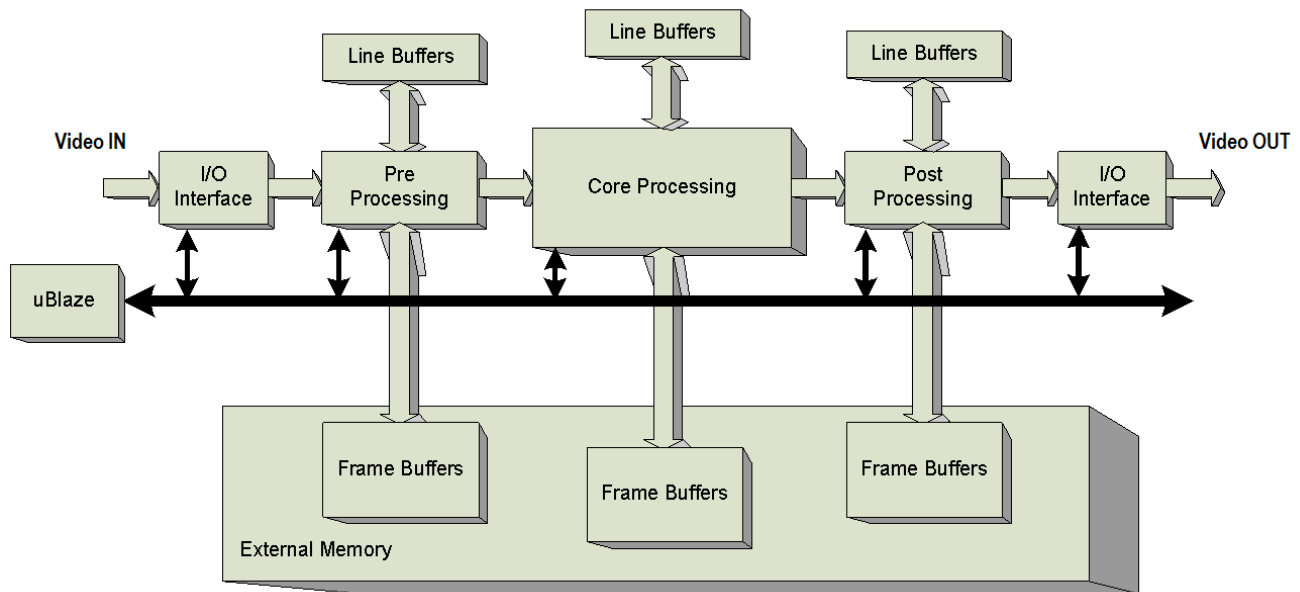

Figure 4-9: Typical Video Processing System

IP Using AXI4-Stream Video Protocol

For comprehensive information about the AXI4-Stream Video IP, see *AXI4-Stream Video IP and System Design Guide* (PG934) [\[Ref 27\]](#).



IMPORTANT: AXI4-Stream only carries active video data, throttled by both the master and slave interfaces.

Note: Blank periods, audio, and ancillary data packets are not transferred using the AXI4-Stream Video Protocol.

Signal Interfaces

Master and Slave interfaces have mandatory signal names.

Input Slave Side Connectors

The following table lists the mandatory interface signal names and functions for the input (slave) side connectors.

Table 4-6: AXI4-Stream Video Protocol Input (Slave) Interface Signals

Function	Width	Direction	AXI4-Stream Signal Name	Video Specific Name
Video Data	Any number of bytes	IN	s_axis_video_tdata	DATA
Valid	1	IN	s_axis_video_tvalid	VALID
Ready	1	OUT	s_axis_video_tready	READY
Start Of Frame	1	IN	s_axis_video_tuser	SOF
End Of Line	1	IN	s_axis_video_tlast	EOL

To avoid naming collisions, append the signal prefix `s_` should be appended to `sk_`, for IP with multiple AXI4-Stream input interfaces, where `k` is the index of the respective input AXI4-Stream. The **AXI4-Stream Signal Name** column lists the mandatory, top-level IP port names. For IP with multiple AXI4-Stream input interfaces, append the `s_axis_video` signal with the index of the respective input AXI4-Stream

Output Master Side Signals

The following table lists the mandatory interface signal names and functions for the output (master) side signals.

Table 4-7: AXI4-Stream Video Protocol Output (Master) Interface Signals

Function	Width	Direction	AXI4-Stream Signal Name	Video Specific Name
Video Data	Any number of bytes	OUT	m_axis_video_tdata	DATA
Valid	1	OUT	m_axis_video_tvalid	VALID
Ready	1	IN	m_axis_video_tready	READY
Start Of Frame	1	OUT	m_axis_video_tuser	SOF
End Of Line	1	OUT	m_axis_video_tlast	EOL

Similarly, for IP with multiple AXI4-Stream output interfaces, append the `m_axis_video_signal` with the index of the respective output AXI4-Stream, shown in [Table 4-7](#).

The **Video Specific Name** column recommends short, descriptive signal names referring to AXI4-Stream ports, to be used in HDL code, timing diagrams, and test benches.

Clocking and ACLK

Each IP using the AXI4-Stream Video Protocol must reference a clock source. Directly-connected master and slave interfaces must be clocked by the same clock source. Any clock available to the IP can be used as the referenced clock source for an AXI interface.

The AXI protocol requires each component interface to use a single clock input signal, ACLK.



IMPORTANT: *The ACLK signal is a mandatory pin on the IP core interface.*

The ACLK pin name can be either appended or prefixed to designate clock functionality, such as `m0_axis_aclk`, or `aclk_out` for IP with multiple AXI4 interfaces using different clocks.

Interface input signals are sampled on the rising edge of ACLK. Output signal changes must occur after the rising edge of ACLK.

On Video IP interfaces, the ACLK pin is not part of the AXI4-Stream component interface; ACLK signals associated with AXI4-Stream component interfaces are provided to Video IP using one or multiple core clock signals. The clock signals can be shared by multiple AXI4-Stream interfaces and signal processing circuitry within the IP.

Signals in each component interface must be synchronous to one of the core clock signals, which are inputs to Video IP cores, but not directly part of the AXI4-Stream Video Protocol interface.

For example, if a core uses a single processing ACLK signal, to which all operations within the core are synchronous, the master and slave AXI4-Stream video interfaces should use this clock signal as their clock reference.

A Video IP core can contain multiple AXI4-Stream interfaces and multiple clocks. Also, for system integration tools, the IP must contain metadata tags identifying clock domain associations.

TDATA Structure

TDATA bits are represented using the ($N-1$ downto 0) or $[N-1 : 0]$ bit numbering convention. The components of implicit subfields of DATA are packed together tightly; for example, a $DW=10$ bit RGB data packed together to 30 bits. If necessary, the packed data word can be zero padded with most significant bit (MSB) so the width of the resulting word is an integer multiple of 8.

Clock Enable, ACLKEN



IMPORTANT: The ACLKEN signal, associated with ACLK, is an optional, recommended pin on the IP core interface.

For IP with multiple AXI4-Stream interfaces using different clocks, the name of the ACLKEN pin can be appended to designate clock association, such as ACLKEN_m0, or ACLKEN_in.

Note: When ACLKEN (clock enable) pins are used (toggled) in conjunction with a common clock source driving the master and slave sides of an AXI4-Stream interface, the ACLKEN pins associated with the master and slave component interfaces must also be driven by the same signal to prevent transaction errors.

Note: When two cores connect using AXI4-Stream interfaces, where only the master or the slave interface has an ACLKEN port, which is not permanently tied high, the two interfaces must be connected using the AXI4 FIFO core to avoid data corruption. See the *AXI4-Stream Infrastructure IP Suite: Product Guide for Vivado Design Suite* (PG085) [Ref 26] for more information.

Reset Requirements, ARESETn

Video IP cores must have two reset source types:

- Reset pins provided in conjunction with the corresponding clocks (hardware reset)
- The software reset option provided by the processor interface



IMPORTANT: An active-Low reset pin, ARESETn, associated with ACLK, is required on the IP core interface. For IP with multiple AXI4-Stream interfaces using different clocks, each clock domain can have corresponding reset signals. The name of the ARESETn pin can be appended to designate clock association, such as ARESETn_m0.

The ARESETn signal takes precedence over ACLKEN. IP with optional ACLKEN inputs that must reset when ARESETn is deasserted regardless of the state of the associated ACLKEN input.

Note: When a system with multiple-clocks and corresponding reset signals are being reset, the reset generator has to ensure all reset signals are asserted/deasserted long enough that all interfaces and clock-domains in all IP cores are correctly re-initialized.

TKEEP and TSTRB



IMPORTANT: TKEEP and TSROBE are not used in IP using AXI4-Stream Video Protocol. When connecting to IP requiring TKEEP or TSTRB assignments, use the default values of TKEEP=1 and TSTRB=1.



RECOMMENDED: AXI4-Stream compliant Video IP should only use the "Continuous Aligned Stream" mode of AXI4-Stream, and use packed data format and TDATA padded to integer (N) multiples of 8 bits (see [Data Format](#)).

- For most video formats, all data bytes are always valid, when `DATA` is qualified by `VALID`.
- For 420 encoded YCbCr / YUV data, only every second video line contains valid Chroma data. For the remaining lines, Luma is zero-padded.

TID

Video IP use designated AXI4-Stream interfaces to transfer video and data streams.



IMPORTANT: *TID is not used in IP using AXI4-Stream Video Protocol.*

Video IP does not forward a slave `TID`, or generate a `TID`, instead, the unconnected `TID` signal defaults to 0.

TDEST



IMPORTANT: *The TDEST signal is not used in IP using AXI4-Stream Video Protocol.*

Video IP does not forward a slave `TDEST`, or generate a `TDEST`, instead, the unconnected `TDEST` signal defaults to 0.

TUSER

`TUSER` bit 0, labeled Start of Frame (see [Start of Frame Signal - SOF](#)) is the only AXI4-Stream signal used for video. Other `TUSER` signal bits are not propagated by video cores.

Signaling Protocol

This section describes how you can use the interface signals and basic protocols of the AXI4-Stream specification to construct streaming interfaces to meet the needs of various video system applications. Generic AXI protocol signals are referenced using signal names reflecting their video specific function.

Channel Structure

The interface contains a set of handshake signals, `VALID` and `READY`, and a set of information-carrying signals, `DATA`, `EOL`, and `SOF`, that are conditioned by the handshake signals.

AXI4-Stream interface signals must operate in the same clock domain; however, the master and slave side can operate in different clock domains. In this case, proper clock-domain crossing logic must be employed when connecting the interfaces.

In the IP integrator, the AXI4-Stream Interconnect IP can be used to simplify connecting AXI4-Stream interfaces in different clock domains.

Note: In this protocol specification, for the sake of simplicity, both master and slave AXI4-Stream interfaces are assumed to operate in the same clock domain, synchronous to `ACLK`, with `ACLKEN=1`, and `ARESETn=1`.

For any given channel, signals propagate from the source (master) to the destination (slave) with the exception of the `READY` signal.

Any other information-carrying or control signals that need to propagate in the opposite direction must be part of a separate interface, `READY` is not used as a mechanism to transfer opposite direction information from a slave to a master.

READY/VALID Handshake



IMPORTANT: A valid transfer occurs when `READY`, `VALID`, `ACLKEN`, and `ARESETn` signals are high at the rising edge of `ACLK`. During valid transfers, `DATA` only carries active video data.

Note: Blank periods, audio, and ancillary data packets are not transferred in IP using the AXI4-Stream Video Protocol.

Guidelines on Driving VALID

After `VALID` is asserted, no other signals in the same channel (except `READY`) can change value until the transfer completes (the cycle after `READY` is asserted). After it is asserted, `VALID` can only be de-asserted after a transfer has completed (`READY` is sampled high). Transfers cannot be retracted or aborted. In any cycle following a transfer (handshake completion), `VALID` can either be de-asserted or remain asserted to initiate a new transfer.

The following figure shows an example of a `READY/VALID` handshake at the start of a new frame.

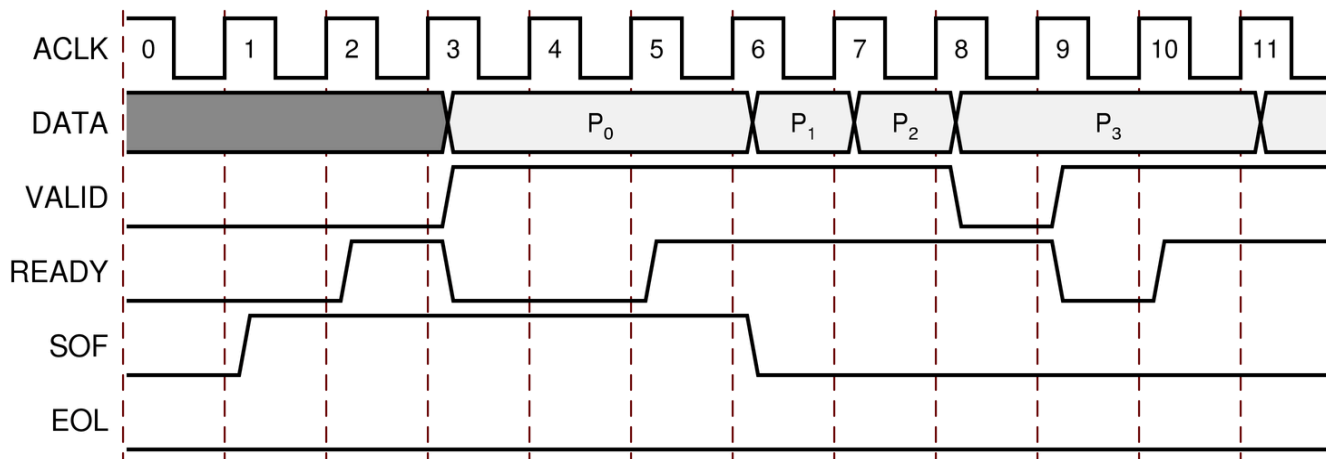

Figure 4-10: Example of Ready/Valid Handshake at Start of New Frame

Driving READY Guidelines

The `READY` signal can be asserted before, during, or after the cycle in which `VALID` is asserted. The assertion of `READY` might be dependent upon the value of `VALID`. The `READY` slave output cannot be generated combinatorially from the `VALID` slave input.

A slave that can immediately accept data qualified by `VALID` must pre-assert its `READY` signal until data is received. Alternatively, `READY` can be registered and driven in the cycle following the `VALID` assertion. The default design convention is as follows:

- A slave must drive `READY` independently.
- or
- Pre-assert `READY` to minimize latency.

Interfacing to AXI4-Stream With No READY Signal

Although `READY` is a required signal for IP using the AXI4-Stream Video Protocol, the AXI4-Stream allows `READY` to be omitted.

In the case that the downstream IP is always ready to receive data, the AXI4-Stream slave interface `READY` signal has a default value of 1. However, the upstream IP AXI4-Stream master interface not having a `READY` could limit interoperability with Video IP that generate `READY`. It is possible to connect an AXI4-Stream master with only forward flow control (`VALID` only) to an AXI4-Stream slave with full flow control, such as Video IP (`READY` and `VALID`). This generally requires knowledge of the data rates and the use of an AXI4-Stream FIFO block, to provide elasticity to handle backpressure from `READY` deassertion.

An example is a Video Input (master) connected to a Video Frame Buffer (slave) that writes to memory. The video camera produces video data that comes in from a unidirectional link such as a DVI cable. The data produced by the camera cannot be back-throttled which is analogous to having `VALID` handshake only.

The Frame Buffer might have to arbitrate with other devices, such as a processor, for memory access. This could require the memory controller to temporarily become unavailable by deasserting `READY` while waiting for memory access.

After the controller grants access to the Frame Buffer write interface, it asserts `READY` and takes data. In this example, having an AXI FIFO between the Video Input IP and the Frame Buffer IP would allow the two to connect to each other. If the FIFO depth is selected correctly by analyzing the memory arbitration process, no data is lost to FIFO overflow.

Start of Frame Signal - SOF

The Start-Of-Frame (`SOF`) signal, physically transmitted over the AXI4-Stream `TUSER0` signal, marks the first pixel of a video field or frame.

The SOF pulse is 1 *valid* transfer wide, and must coincide with the first pixel of the field or frame. SOF (TUSER0) is defined on a data beat, and is associated technically with the least significant byte of the beat, if between AXI4-Stream infrastructure cores TDATA and TUSER are byte-aligned, or go through width conversions.

The SOF does the following:

- Serves as a field or frame synchronization signal, which allows downstream cores to re-initialize, and detect the first pixel of a field or frame
- Can be asserted an arbitrary number of ACLK cycles before the first pixel value is presented on DATA, as long as a VALID is not asserted

Parameterization and/or configuration registers define the dimensions of the video field or frames that video IP can process. Starting from a known state, based on these configuration settings the IP can predict when the beginning of the next frame is expected.

The SOF that is detected before expected (early), or the SOF that is not present when it is expected (late), signals error conditions indicative of either upstream communication errors or incorrect core configuration. It is recommended that Video IP flag both error conditions with dedicated flags in the core ERROR register.



RECOMMENDED: *Recommended flag names are sk_SOF_EARLY and sk_SOF_LATE, where k is the index of the AXI4-Stream slave interface. Also, it is recommended that these flags can trigger interrupts, so embedded application developers can quickly identify faulty interfaces or incorrectly parameterized cores in a video system.*

Also, to minimize the impact of sustained error conditions it is **recommended**, but not mandated, that:

- When the SOF_EARLY condition is detected, if possible, the IP immediately start processing the new frame. All pixels pertaining to the previous frame should be processed, the last sample of the previous frame should be qualified with the EOL signal, and processing of the new frame should commence.
- When the SOF_LATE condition is detected, the IP should drop (accept on the input, but not propagate to the output) subsequent pixels until the SOF signal arrives.

End Of Line Signal - EOL

The End-Of-Line (EOL) signal, physically transmitted over the AXI4-Stream TLAST signal, marks the last pixel of a line. The EOL pulse is 1 *valid* transfer wide, and must coincide with the last pixel of a scan-line, shown in the following figure.

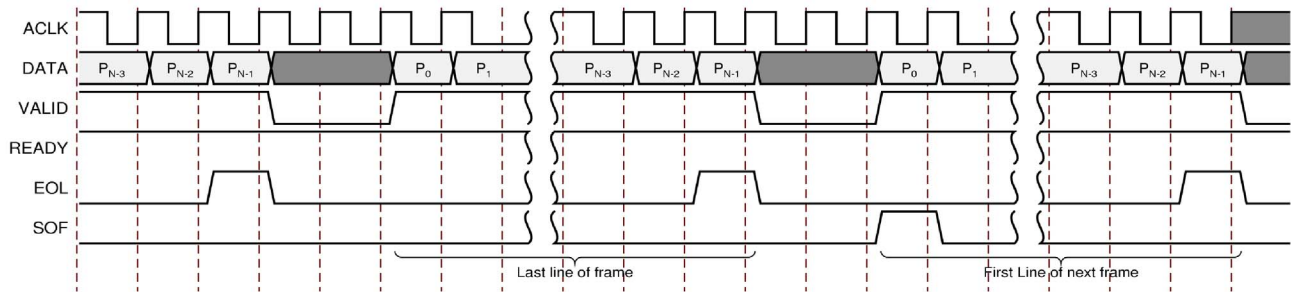

Figure 4-11: Use of EOL and SOF Signals

Parameterization and/or configuration registers define the dimensions of video frames that video IP should process. Starting from a known state, based on these configuration settings the IP can predict when the last pixel of each scanline is expected. The EOL detected before expected (early), or EOL not present when expected (late), signals error conditions indicative of either upstream communication errors or incorrect core configuration.



RECOMMENDED: It is recommended that video IP flags both error conditions with dedicated flags in the core ERROR register. Recommended flag names are `sk_EOL_EARLY` and `sk_EOL_LATE`, where `k` is the index of the AXI4-Stream slave interface. It is recommended that these flags can trigger interrupts, so embedded application developers can quickly identify faulty interfaces or incorrectly parameterized cores in a video system.

Also, to minimize the impact of sustained error conditions it is recommended, but not mandated, that:

- When the `EOL_EARLY` condition is detected, if possible, the IP should immediately start processing the new line. All pixels pertaining to the previous frame should be flushed out, the line should be qualified with the EOL signal, and processing of the new line should commence.
- When the `EOL_LATE` condition is detected, the IP must generate its output EOL signal according to the programmed/parameterized line-length, and drop (accept on the input, but not propagate to the output) subsequent pixels until the EOL signal arrives.

Real Time Requirements

The AXI4-Stream interface protocol does not impose any rules on real-time requirements. Video IP should not impose strict cycle-to-cycle real-time requirements on data transfers, other than to meet and not break the fundamental AXI handshake rules at the AXI4-Stream interface. The IP must meet the constraint on the clock signal to which the interface is synchronous.

Data Format

To transport video data, the DATA vector encodes logical channel subsets of physical DATA signals. Various AXI4-Stream interfaces between the modules can facilitate transferring video using different precision (for example; 8, 10, 12, or 16 bits per color channel), and/or different formats (for example RGB or YUV 420).

A specific example of a typical image pre-processing system is illustrated in the following figure, which consists of a number of Xilinx IP cores connected using AXI4-Stream to implement an imaging sensor processing pipeline.

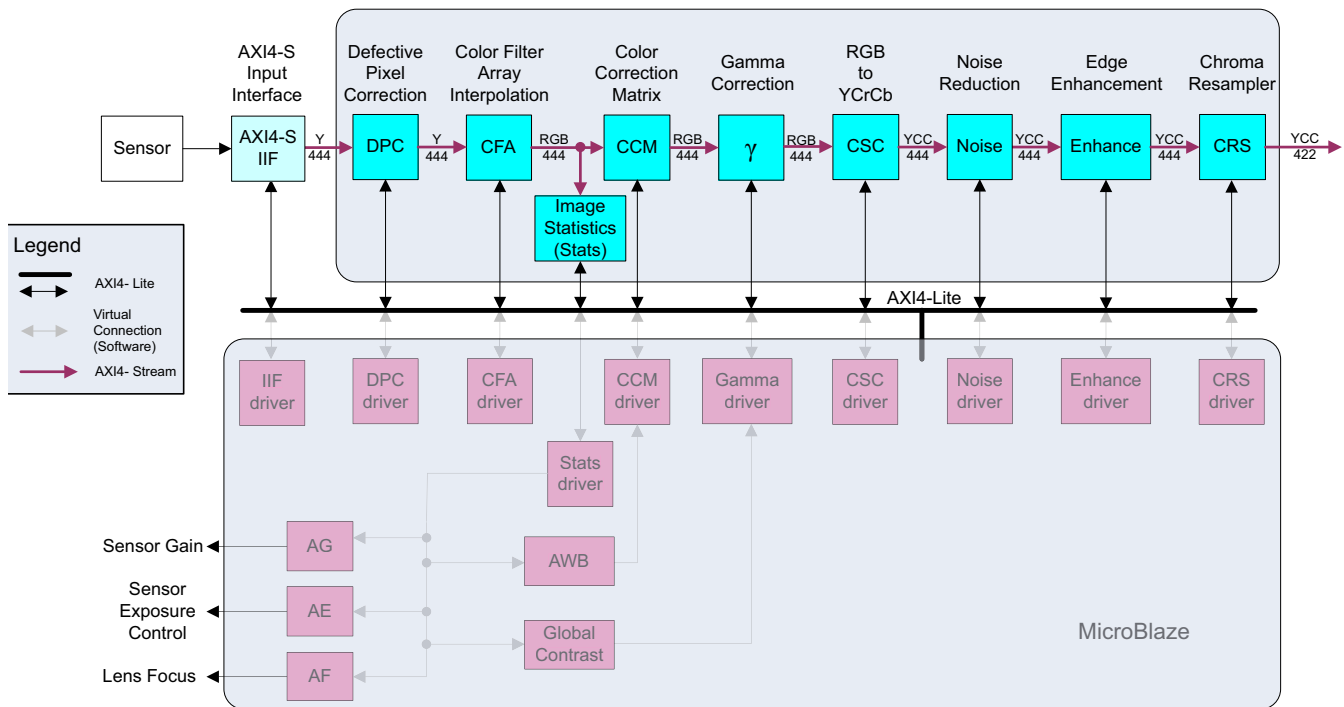

Figure 4-12: Image Processing Pipeline

AXI4-Stream channels in Figure 4-12 are annotated to reflect the transferred video format. The DATA signal must not have any explicit subfields defined, either as separate ports or with special signal suffixes.

For example, cores with `DATA_Y` and `DATA_C` signals are not permitted. Format information is embedded in the IP-XACT representation of IP as metadata tags attached to AXI4-Stream ports.

AXI4-Stream Specific Parameterization

The following table lists the parameters specific to IP using the AXI4-Stream Video Protocol. The paragraphs immediately following the table provide further description.

Table 4-8: IP using AXI4-Stream Video Protocol Parameters

Parameter Name	Parameter Function
<code>C_tk_DATA_WIDTH</code>	Width of color/component data.
<code>C_tk_VIDEO_FORMAT</code>	Video format code (see following description).
<code>C_tk_AXIS_TDATA_WIDTH</code>	Width of the <code>DATA</code> interface signal.
<code>C_tk_MAX_SAMPLES_PER_CLOCK</code>	Maximum number of samples/pixels per data beat.

The `C_tk_AXIS_TDATA_WIDTH` parameter determines the width of the variable-width `DATA` interface signal on AXI4-Stream interface `t`, where interface type `t` can have the values [`m`, `s`] designating a master or slave interface, while optional integer `k` specifies the interface ID. Typically, `C_tk_AXIS_TDATA_WIDTH` is a function of the component data width, the number of pixels/samples per data beat, and the number of components the actual video format is using.

The recommended parameter names for component data width is `C_tk_DATA_WIDTH`. Supported component widths are 8, 10, 12, and 16 bits. The optional format parameter `C_tk_VIDEO_FORMAT` can assist the IP in determining the number of color or components present on `DATA` using a HDL function. Video IP is typically very specific on the formats expected on the input interfaces, and could already have the number of color or component channels hard coded in the IP. However, when the `C_tk_VIDEO_FORMAT` parameter, set by a default value on the master interface, is propagated in HDL designs to slave interfaces, the IP source code can perform DRC by means of assertions to ensure that AXI4-Stream video interfaces are driven by video encoded in the expected format.

The `C_tk_MAX_SAMPLES_PER_CLOCK` parameter specifies the maximum number of samples/pixels being transferred in parallel on `TDATA`. See [Encoding](#) for more information.

Encoding

The `DATA` bits are represented using the `[N-1:0]` bit numbering convention (N-1 through 0). The components of implicit subfields of `DATA` should be packed tightly together; for example, a `DW=10` bit RGB data packed together to 30 bits. If necessary, the packed data word should be zero padded with most significant bits (MSBs) so the width of the resulting word is an integer that is a multiple of eight as shown in the following figure.

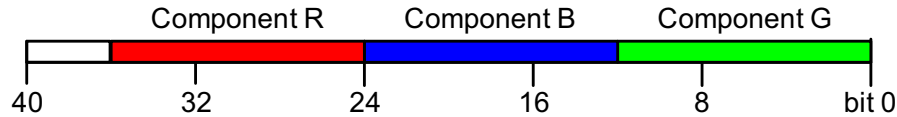

Figure 4-13: Video Data Padding for TDATA

The following table provides detailed representation of different formats, with $DW = C_DATA_WIDTH$ and $VF = C_VIDEO_FORMAT$. It lists the detailed representation of video data formats, with $DW = C_DATA_WIDTH$ and $VF = C_VIDEO_FORMAT$.

 Table 4-9: Video Format Codes and Data Representation for $C_tk_MAX_SAMPLES_PER_CLOCK = 1$

VF Code	Video Format	[4DW-1: 3DW]	[3DW-1: 2DW]	[2DW-1: DW]	[DW-1:0]
0	YUV 4:2:2			V/U, Cr/Cb	Y
1	YUV 4:4:4		V, Cr	U, Cb	Y
2	RGB		R	B	G
3	YUV 4:2:0			V/U, Cr/Cb	Y
4	YUVA 4:2:2		a	V/U, Cr/Cb	Y
5	YUVA 4:4:4	a	V, Cr	U, Cb	Y
6	RGBA	a	R	B	G
7	YUVA 4:2:0			α , V/U, Cr/Cb	Y
8	YUVD 4:2:2		D	V/U, Cr/Cb	Y
9	YUVD 4:4:4	D	V, Cr	U, Cb	Y
10	RGBD	D	R	B	G
11	YUV 4:2:0		D	V/U, Cr/Cb	Y
12	Mono/Sensor				Y, RGB, CMY
13	Custom2			2 Components – No DRC	
14	Custom3			3 Components – No DRC	
15	Custom4			4 Components – No DRC	

Encoding Multiple Pixels

When multiple samples/pixels are carried by AXI4-Stream, pack the pixels from least significant bit (LSB) to most significant bit (MSB). For example, the least significant pixel corresponds to the left-most pixel in a scanline, or to the pixel captured earliest in time.

For example, if 4 samples/pixels are sent per data beat, the first sample sits in the least significant, the 4th sample sits in the most significant bit positions.

When multiple pixels or samples are transferred using the video protocol over AXI4-Stream, color components pertinent to the individual pixels are arranged according to [Table 4-10](#), presenting examples for transferring two pixels for video modes 0, 1, 2, 3, 12. Pixel data is packed continuously without any padding between pixels.

When $N \cdot DW$ is not an integer multiple of 8, video data is zero padded on the MSBs, as presented in the following figure.

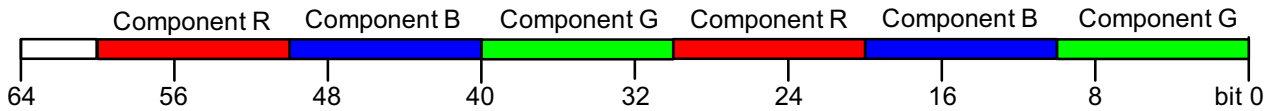

Figure 4-14: Video Data Padding for TDATA for Multiple Pixels

Table 4-10: Video Format Codes and Data Representation

VF Code	Video Format	[6DW-1: 5DW]	[5DW-1: 4DW]	[4DW-1: 3DW]	[3DW-1: 2DW]	[2DW-1: DW]	[DW-1:0]
0	YUV 4:2:2			V1/U1, Cr1/Cb1	Y1	V0/U0, Cr0/Cb0	Y0
1	YUV 4:4:4	V1, Cr1	U1, Cb1	Y1	V0, Cr0	U0, Cb0	Y0
2	RGB	R1	B1	G1	R0	B0	G0
3	YUV 4:2:0			V1/U1, Cr1/Cb1	Y1	V0/U0, Cr0/Cb0	Y0
12	Bayer Sensor					RGB1, CMY1	RBGB0, CMY0

Dynamic TDATA Configuration

For applications where video IP can dynamically change color-component width, video format, or the number of pixels/samples per data beat, pixels and components should remain at the static locations determined by the generic parameters for instantiation. Actual data on the TDATA vector should be LSB aligned; for example, if only one pixel is transmitted over an interface supporting at most two pixels per data beat, the sample/pixel should be aligned to the LSB position. Similarly, if only 8 bits are transmitted over an interface generated for 10 bit data, the active bits should be LSB aligned and MSB padded, shown in the following figure.

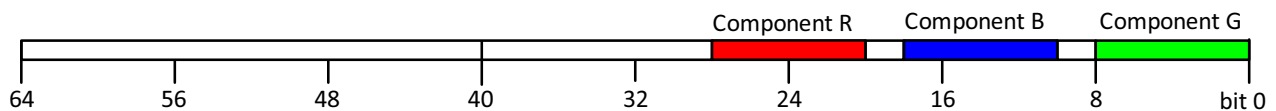

Figure 4-15: TDATA Padding for Dynamic AXI4- Configuration

Migrating to Xilinx AXI Protocols

Introduction

Migrating an existing core is a process of mapping the I/O signal of your core to corresponding AXI protocol signals. In some cases, additional logic might be needed.

Migrating to AXI for IP Cores

Xilinx provides the following guidance for migrating IP.

See [Memory-Mapped IP Feature Adoption and Support](#) as well as the *ARM AMBA AXI Protocol v2.0 Specification* specification [Ref 1] available from the ARM website. New IP should be designed to the AXI protocol.

IP that was created using the Create and Import Peripheral (CIP) Wizard in a previous version of Xilinx tools (before AXI was supported) can be migrated by rerunning the CIP Wizard in the ISE® Design Suite to create AXI-based template designs.

IP that needs to remain unchanged can be used in the Xilinx tools using the AXI to PLB bridge.

Larger pieces of Xilinx IP (often called *Connectivity* or *Foundation* IP): This class of IP has migration instructions in the respective documentation. This class of IP includes: PCIe®, Memory Core, and Serial Rapid I/O.

DSP IP: General guidelines on converting this broad class of IP is covered in this [link](#) to the “Migrating Designs to Vivado IDE” chapter of the *Vivado Design Suite User Guide: Model-Based DSP Design Using System Generator* (UG897) [Ref 31].

EDK IP: Converting EDK IP is a manual process, described in the *ISE to Vivado Migration Guide* (UG911) [Ref 35].

Migrating IP Using the Vivado Create and Package Wizard

The Vivado IDE contains a tool (see the following figure) to help you create a new AXI IP. The tool lets you specify AXI interface characteristics and then the tool creates and packages a working example AXI IP. This template IP implements some simple demonstration functionality and can be created with an example test bench to exercise the IP using the AXI Verification IP (VIP) modes. This gives you a starting point from which to design your own custom AXI IP.

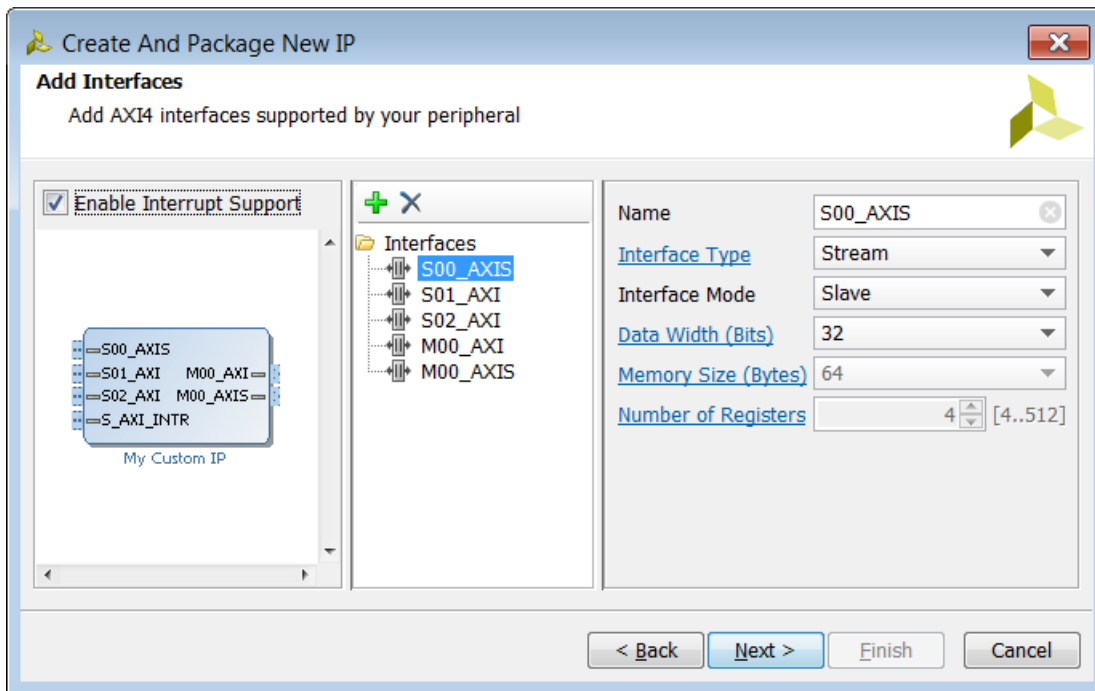

Figure 5-1: Create and Package IP Wizard: AXI Interfaces

For more information about creating AXI IP using this wizard, see the *Vivado Design Suite User Guide: Creating and Packaging Custom IP* (UG1118) [Ref 33].

Using System Generator for DSP for Migrating IP

System Generator for DSP has an **Upgrade Model** feature that can assist you in migrating designs previously created in ISE System Generator to designs that are compatible with the Vivado Integrated Design Environment (IDE) and include AXI4 interfaces.

See this [link](#) to the "Migrating Designs to Vivado IDE" chapter in the *Vivado Design Suite User Guide: Model-Based DSP* (UG897) [Ref 31] for more information.

Migrating a Fast Simplex Link to AXI4-Stream

When converting a Fast Simplex Link (FSL) peripheral to an AXI4-Stream peripheral there are several considerations. You must migrate the:

- Slave FSL port to an AXI4-Stream slave interface
- Master FSL port to an AXI4-Stream master interface

The following tables list the master-FSL and slave-FSL to AXI4-Stream signals conversion mappings.

Master FSL to AXI4-Stream Signal Mapping

The following table shows the AXI4-Stream signal mapping.

Table 5-1: AXI4-Stream Signal Mapping

Signal	Direction	AXI Signal	Direction
FSL_M_Clk	Out	M_AXIS_<Port_Name>ACLK	In
FSL_M_Write	Out	M_AXIS_<Port_Name>TVALID	Out
FSL_M_Full	In	M_AXIS_<Port_Name>TREADY	In
FSL_M_Data	Out	M_AXIS_<Port_Name>TDATA	Out
FSL_M_Control	Out	M_AXIS_<Port_Name>TLAST	Out

Slave FSL to AXI4-Stream Signal Mapping

The following table shows the FSL to AXI4-Stream signal mapping.

Table 5-2: FSO to AXI-4 Stream Signal Mapping

Signal	Direction	AXI Signal	Direction
FSL_S_Clk	Out	S_AXIS_<Port_Name>ACLK	In
FSL_S_Exists	In	S_AXIS_<Port_Name>TVALID	In
FSL_S_Read	Out	S_AXIS_<Port_Name>TREADY	Out
FSL_S_Data	In	S_AXIS_<Port_Name>TDATA	In
FSL_S_Control	In	S_AXIS_<Port_Name>TLAST	In

Differences in Throttling

There are fundamental differences in throttling between FSL and AXI4-Stream, as follows:

- The `M_AXIS_TVALID` signal cannot be deasserted after being asserted unless a transfer is completed with `M_AXIS_TREADY`. However, an `M_AXIS_TREADY` can be asserted and deasserted whenever the AXI4-Stream slave requires assertion and deassertion.
- For FSL, the signals `FSL_Full` and `FSL_Exists` are the status of the interface; for example, if the slave is full or if the master has valid data
- An FSL-master can have a pre-determined expectation prior to writing to FSL to check if the FSL-Slave can accept the transfer based on the FSL slave having a current state of `FSL_Full`
- An AXI4-Stream master cannot use the status of `S_AXIS_TREADY` unless a transfer is started.

The MicroBlaze™ processor has an FSL test instruction that checks the current status of the FSL interface. For this instruction to function on the AXI4-Stream, MicroBlaze has an additional 32-bit Data Flip-Flop (DFF) for each AXI4-Stream master interface to act as an output holding register.

When MicroBlaze executes a `put fsl` instruction, it writes to this DFF. The AXI4-Stream logic inside MicroBlaze moves the value out from the DFF to the external AXI4-Stream slave device as soon as the AXI4-Stream allows. Instead of checking the AXI4-Stream `TREADY/TVALID` signals, the FSL test instruction checks if the DFF contains valid data instead because the `S_AXIS_TREADY` signal cannot be directly used for this purpose.

The additional 32-bit DFFs ensure that all current FSL instructions to work seamlessly on AXI4-Stream. There is no change needed in the software when converting from FSL to AXI4 stream.

For backward compatibility, the MicroBlaze processor supports keeping the FSL interfaces while the normal memory-mapped AXI interfaces are configured for AXI4.

This is accomplished by having a separate, independent MicroBlaze configuration parameter (`C_STREAM_INTERCONNECT`) to determine if the stream interface should be AXI4-Stream or FSL.

Migrating HDL Designs to use DSP IP with AXI4-Stream

Adopting an AXI4-stream interface on a DSP IP should not change the functional, or signal processing behavior of the DSP function such as a filter or a FFT transform. However, the sequence in which data is presented to a DSP IP could significantly change the functional output from that DSP IP. For example, one sample shift in a time division multiplexed input data stream will provide incorrect results for all output time division multiplexed data.

To facilitate the migration of an HDL design to use DSP IP with an AXI4-Stream interface, the following subsections provide the general items to consider:

- [DSP IP-Specific Migration Instructions](#)
- [Demonstration Test Bench](#)
- [Latency Changes](#)
- [Mapping Previously Assigned Ports to An AXI4-Stream Video Protocol](#)

DSP IP-Specific Migration Instructions

This section provides an overview with IP specific migration details available in each respective data sheet. Before starting the migration of a specific piece of IP, review the “AXI4-Stream Considerations” and “Migrating from earlier versions” in the individual IP Data Sheets or Product Guides.

The following figure shows an example.

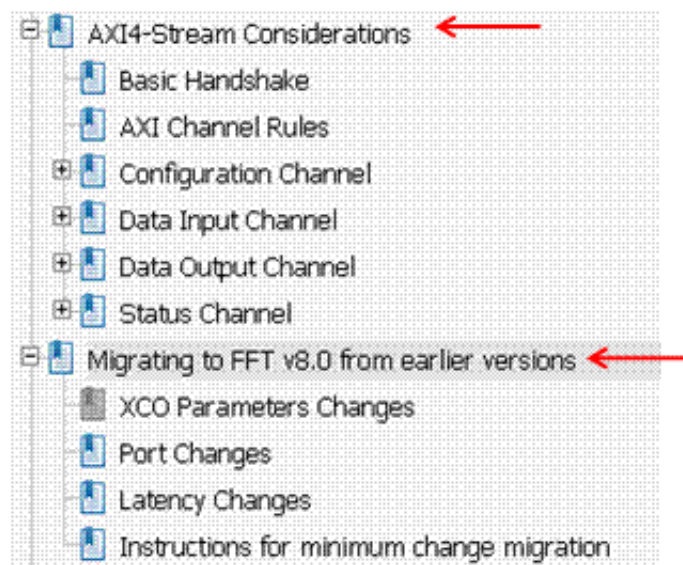

Figure 5-2: Example IP Data Sheet

Demonstration Test Bench

To assist with core migration, the Vivado Video IP generate an example test bench in the `demo_tb` directory under the Vivado IP project directory. The test bench instantiates the generated core and demonstrates a simple example of how the DSP IP works with the AXI4-stream interface. This is a simple VHDL test bench that exercises the core.

The demonstration test bench source code is one VHDL file, `demo_tb/tb_<component_name>.vhd`, in the Vivado IP output directory.

The source code is comprehensively commented. The demonstration test bench drives the input signals of the core to demonstrate the features and modes of operation of the core with the AXI4-Stream interface. For more information on how to use the generated test bench see the "Demonstration Test bench" section in the individual IP data sheet.

The following figure shows the `demo_tb` directory structure.



Figure 5-3: `demo_tb` Directory Structure

Upgrading IP

Upgrade IP to the latest version by using one of the following:

- The **Upgrade IP** option in the right-click menu of the selected IP
- The **Report IP Status** command

See more information see this [link](#) to the "Upgrading IP" section in the *Vivado Design Suite User Guide: Designing with IP* (UG896) [Ref 30].

Note: The upgrade mechanism alone does not create a core compatible with the latest version but does provide a core that has equivalent parameter selection as the previous version of the core. The core instantiation in the design must be updated to use the AXI4-Stream interface. The upgrade mechanism also creates a backup of the old XCO file. The generated output is contained in the `/tmp` directory of the CORE Generator project.

Latency Changes

With DSP IP that support the AXI4-Stream interface, each individual AXI4-Stream slave channel can be categorized as either a *blocking* or a *non-blocking* channel. A slave channel is blocking when some operation of the core is inhibited until a transaction occurs on that channel. In general, the latency of the DSP IP AXI4-Stream interface is static for non-blocking and variable for blocking mode. To reduce errors while migrating your design, pay attention to the “Latency Changes” and “Instructions for Minimum Change Migration” sections of the IP data sheet.

Mapping Previously Assigned Ports to An AXI4-Stream Video Protocol

The individual DSP IP datasheets provide a table about the changes to port naming, additional or deprecated ports, and polarity changes from previous version to the latest version of the core. Noteworthy changes are:

- **Resets:** The DSP IP AXI4-stream interface `aresetn` reset signal is active-Low and must be asserted for a minimum length of two clock cycles. The `aresetn` reset signal always takes priority over the `ac1ken` clock enable signal. Therefore your IP instantiation reset input must change from an active-High “SCLR” signal with a minimum length of one clock cycle, to a active-Low reset input with a minimum of two clock cycles.
- **Input and Output TDATA port structure:** The AXI specification calls for data to be consolidated onto a single `TDATA` input stream. For ease of visualization you can view the `TDATA` structure from the IP symbol and implementation details tab in the IP GUI. For ease of IP instantiation the demonstration example testbench also shows how to connect and functionally split signals from the `TDATA` structure. The demonstration testbench assigns `TDATA` fields to aliases for easy waveform viewing during simulation.

The following figure shows the TDATA port structure.

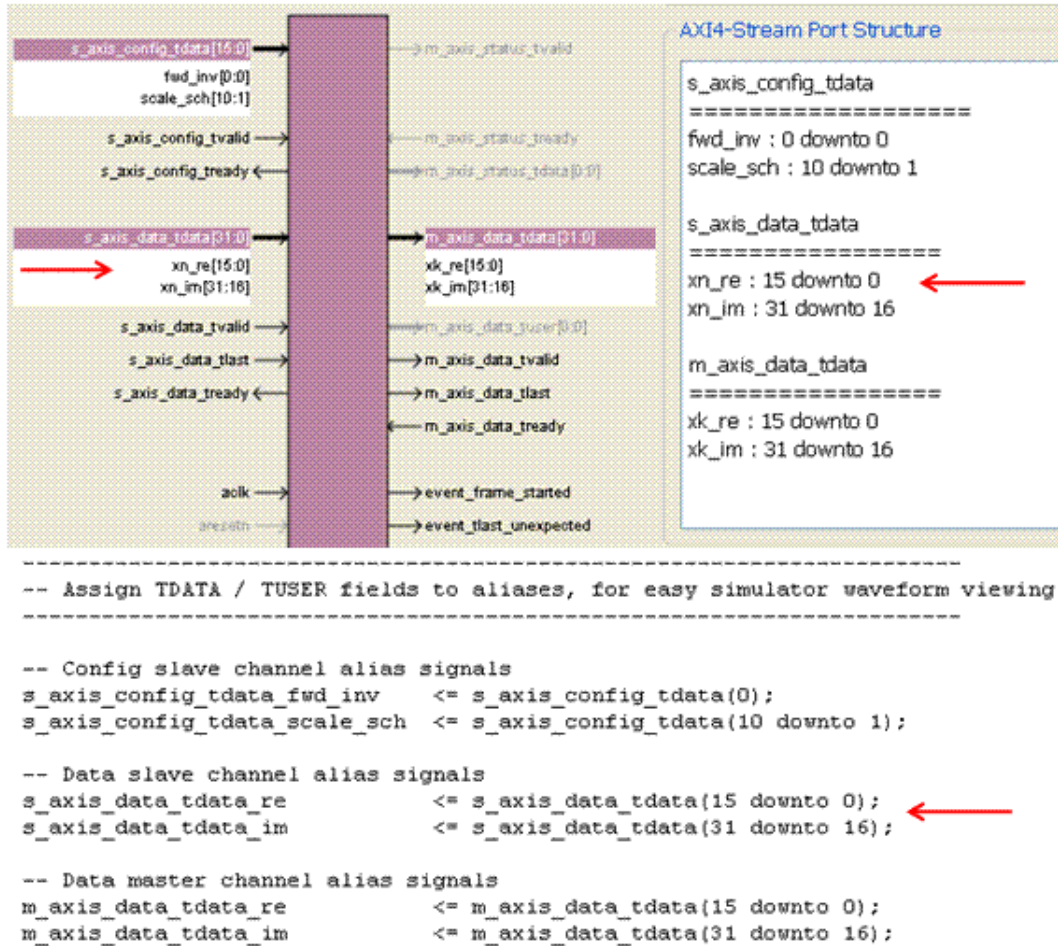

Figure 5-4: TDATA Port Structure

High End Verification Solutions

Many third-party companies (such as Cadence Design Systems, ARM, Mentor Graphics, and Synopsys) have tools whose function is to allow system-level verification and performance tuning for system-level design. When designing large AXI-based systems, if the highest possible verification and performance are required, it is recommended that third-party tools be used.

AXI System Optimization: Tips and Hints

Introduction

AXI-based Xilinx® IP, third-party IP, and user IP present a wide range of configuration options and design choices that let you tune a system for size, Fmax, throughput, latency, ease of use, and ease of debug. IP design decisions and system architecture also impact the area and performance of the system.

Given that AXI-based systems must span a wide solution space from small Spartan® and Artix® class designs to very large, high performance Virtex®, Kintex®, Zynq®-7000 AP SoC and Zynq UltraScale+™ MPSoC processor designs, there is a large configuration space for AXI IP and systems.

This chapter provides information and presents concepts that help you optimize your IP designs and system configurations. In some cases, optimization for one attribute might conflict with another requiring you to balance competing tradeoffs. For example, improving timing through the use of additional pipelining negatively impacts area.

[Table 6-1](#) and [Table 6-2](#) illustrate the impact of different AXI Interconnect, AXI SmartConnect, and IP features, configuration parameters, and optimization options across various criteria. The impact on each criterion is qualitatively described using a positive to negative scale of Best (++) , Better (+) , Neutral (0) , Worse (-) , and Worst (--). When creating an architecture, optimizing, or diagnosing systems, use these tables to help with designing the IP or system to maximize the attributes required by the application while minimizing negative trade-offs.

You need to be familiar with the AXI infrastructure IP, or AXI SmartConnect IP, and general Vivado embedded tool usage to better understand the optimization suggestions and strategies described in this chapter.

Table 6-1: AXI Interconnect Optimization/Feature Impact

Feature	Configuration	Size/Area	Timing/Fmax	Throughput	Latency	Ease of Use/Flexibility	Ease of Debug	Notes
Clock Domain Conversion (Optional, Default = OFF)	Synch Clock Conversion	-	+	0	-	+	0	Synch clock conversions require complex multi-cycle timespecs (core level UCF is automatically generated by AXI Interconnect and AXI SmartConnect).
	Async Clock Conversion	--	+	0	--	++	0	Asynchronous clock conversion includes a 32-bit deep FIFO or is merged into BRAM FIFO logic. Synchronized conversion is generally preferred over asynchronous conversion.
Width Conversion (Optional, Default = OFF)	Downsizer	--	--	--	-	+	0	For AXI Interconnect, size converters do not support multi-threading. They will stall when IDs change until transactions on previous IDs are complete.
	Upsizer	--	-	-	-	+	0	
Endpoint Slave Protocol Conversion from AXI4, (Optional, Default = OFF)	AXI4-Lite	0	0	--	0	+	++	For AXI Interconnect, the AXI3 converter does not support multi-threading when splitting is enabled. It will stall when IDs change until transactions on previous IDs are completed. AXI3 converter also requires logic to handle splitting of long AXI4 bursts to AXI3 bursts of maximum length of 16. This logic adds size and latency.
	AXI3	-	-	-	-	0	0	
Connectivity Mode	Shared Access Shared Data	++	0	--	0	+	++	
	Crossbar - Sparse (Default)	0	+	+	0	0	0	
	Crossbar - Fully Connected	--	-	+	0	0	0	
ID Threading	Single Thread	+	+	0	0	+	+	Applies when a master declares that it does not use IDs or interconnect is explicitly placed into Single Thread mode. Note that configuration setting such as Shared Address Shared Data mode (SASD), size conversion, or protocol conversion, might automatically cause Single Thread mode to be used.
	Multiple Thread Support	0	0	+	0	0	-	As more threads are used and there is a greater potential for read reordering or read interleaving, the more difficult it is to debug.
Issuance/Acceptance	1 (Default)	+	+	-	0	+	+	
	2, 4, 8, 16, 32	-	0	+	-	0	-	

Legend: "+ + +" = Best; "+" = Better, "0" = Neutral, "-" = Worse, "--" = Worst

Table 6-1: AXI Interconnect Optimization/Feature Impact (Cont'd)

Feature	Configuration	Size/Area	Timing/Fmax	Throughput	Latency	Ease of Use/Flexibility	Ease of Debug	Notes
Datapath Width	32 (Default)	+	+	-	0	0	0	
	64, 128, 256, 512, 1024	--	-	++	0	0	0	
Register Slice (Optional, Default = OFF)	Type 7 (Light Weight)	-	++	-	-	+	0	AXI Interconnect has added a "Type 8" register slice that automatically selects the register slice type based upon interconnect configuration. Type 8 is recommended and should be overridden only when warranted. SmartConnect also offers multiple internal pipelining options.
	Type 1 (Fully Registered)	--	++	0	-	+	0	
	Type 8 (Automatic)	-	++	0	-	+	0	
Floorplanning (Optional, Default = OFF)	Floorplan IP Blocks And/Or Submodules	0	+	0	0	--	0	
Datapath FIFOs (Optional, Default = OFF)	SRL	-	0	+	-	0	0	SRL FIFO is 32 deep. FIFO depths are more configurable in SmartConnect.
	BRAM	--	0	++	-	0	0	BRAM FIFO is 512 deep. Use of additional BRAM FIFO option, to delay <code>AWVALID</code> / <code>ARVALID</code> until FIFO occupancy permits interrupted burst transfers, can further improve throughput at the expense of increased latency.
Arbitration Priority (Optional, Default = Round Robin)	Fixed Priority Over Round Robin	0	0	0	+	-	0	Each master can be assigned a higher fixed priority that supersedes masters at the default priority level of 0. Masters set to the default priority of 0 share Round Robin priority. SmartConnect does not currently support arbitration priority options.
AXI System Debug Wizard (Optional, Default = OFF)	ON	-	-	0	0	0	++	
AXI Hardware Protocol Checker (Optional, Default = OFF)	ON	-	-	0	0	0	++	

Legend: "++" = Best; "+" = Better, "0" = Neutral, "-" = Worse, "--" = Worst

Table 6-2: AXI Endpoint IP Optimization/Feature Impact

Feature	Configuration	Size/Area	Timing/Fmax	Throughput	Latency	Ease of Use/Flexibility	Ease of Debug	Notes
IP Protocol	AXI4-Lite	++	0	-	0	+	++	AXI Interconnect is natively AXI4-based. Use of AXI3 protocol not recommended for new designs.
	AXI4	0	0	0	0	0	0	
Narrow Burst Support	ON (Default)	--	-	-	-	0	0	Narrow burst is assumed to be ON unless the AXI master IP specifically designates this as OFF. Xilinx AXI master IP generally do not use narrow burst and designate themselves as OFF.
	OFF (Recommended)	0	0	0	0	0	0	
Threading	Uses No Thread or Issues Only a Single Thread	+	+	0	0	+	+	Using a single thread while intermixing transactions destined to multiple different AXI slave endpoints could trigger stalling by the deadlock avoidance logic in the AXI Interconnect.
	Issues Multiple Threads	0	0	+	0	0	-	
Ability to Pipeline Transactions	1	+	+	-	0	+	+	New transactions pipelined behind high numbers of pipelined transactions might experience high latency, but throughput might be improved. Head of line blocking can be caused by excessively pipelined transactions.
	> 1 up to 32	-	0	+	0	0	0	
Datapath Width	32	+	+	-	0	0	0	Native data path width should be minimized while meeting performance requirements of application. The caveat is that support for a wider native width that minimizes size conversion in a system could be more beneficial.
	64, 128, 256, 512, 1024	--	-	++	0	0	0	
AXI4 Burst Length	Short (1-4)	0	0	-	+	0	0	Head of line blocking can be caused by long bursts. Transactions pipelined behind long bursts might experience high latency, but throughput might be improved.
	Long (up to 256)	0	0	++	--	0	0	

Legend: "++" = Best; "+" = Better, "0" = Neutral, "-" = Worse, "--" = Worst

AXI System Optimization

In general, system optimization follows the guidelines in the following subsections.

Size/Area Optimization Guidelines

When considering your AXI IP or system design, use the following size and area guidelines:

1. Minimize the clock domain conversions by reducing the logic associated with clock domain conversion. Use as few clocks as possible and, if clock conversion is necessary, attempt to keep the clocks to synchronous integer ratios.
2. Shared Address Shared Data (SASD) configurations of the AXI Interconnect, especially for AXI4-Lite networks. Analyze the connectivity and bandwidth requirements of the system.
An SASD set of connected data configuration consumes even less logic because a single data path is shared by all devices and only one transaction is outstanding at a time.
3. Reduce use of multi-threading in AXI memory-mapped IP including reduced values of issuance or acceptance. Reducing use of threads and transaction pipelining simplifies the transaction handling logic of the AXI Interconnect, but throughput could be impacted.
4. Avoid using AXI3 or AXI4 narrow bursts. Narrow bursts are defined in the AXI protocol but are generally not used by master IP. When a master IP specifically designates that they do not issue narrow bursts, some slaves (such as memory controllers) can detect that they will therefore never receive a narrow burst transaction and can omit narrow burst support logic.



IMPORTANT: *Minimize protocol conversions and use AXI4-Lite where possible. Protocol conversion to AXI3 slaves utilizes logic. The AXI4-Lite protocol requires less logic to support, especially when all devices on an AXI Interconnect are AXI4-Lite type. Using AXI4-Lite protocols and grouping AXI4-Lite IP into a separate subsystem can reduce logic.*

5. Where appropriate, segment interconnects into smaller, less complex subsystems where each subsystem can be optimized as described in the previous steps. This requires analysis of the protocol types, bandwidth, and master/slave connectivity. Grouping IP into subsystems that minimize connectivity requirements and minimize the number of conversion operations can reduce logic.
6. Reduce data path width and minimize size and width conversions. Design systems to the minimum required data path width while also minimizing width conversions.



CAUTION! *Be careful to **not** inadvertently mismatch the AXI Interconnect/AXI SmartConnect core data width or core clock with the width and clock of all the attached endpoints; this can result in an excessive*

number of conversions. If possible, handle width conversion inside the user IP instead of using a general-purpose memory-mapped AXI width converter.

A protocol-compliant AXI memory-mapped width converter block is complex due to issues like address calculation, multi-thread support, transaction splitting, unaligned bursts, and arbitrary burst length.

If width conversion can be performed more efficiently in the user IP or in the application domain before reaching the AXI interconnect, the overall area is reduced.

Timing and Fmax Optimization Guidelines

1. Turn on register slices or pipelines where appropriate. Register slices act as AXI pipeline stages to break combinatorial timing paths across the register slice. AXI Interconnect/AXI SmartConnect provides an optional register slice at the boundary of each attached endpoint. Different register slice types and the granularity to set them on individual AXI channels provides fine grain control of register slices placement.
2. Large and complex IP blocks such as processors, DDR3 memory controllers, and PCIe bridges are good candidates for having register slices enabled. The register slice breaks timing paths and allows more freedom for Place and Route (PAR) tools to move a large IP block away from the congestion of the interconnect core and other IP logic.
 - a. Overuse of register slices, especially in relatively full designs, can become counter-productive to timing by increasing the area and therefore the congestion for PAR tools.
 - b. As required by the AXI specification, user IP must avoid combinatorial paths between inputs and outputs of the same AXI interface. This AXI protocol rule helps improve overall system timing.
3. Reduce data path width and minimize size/width conversions.
4. Where appropriate, segment interconnects into smaller or less complex subsystems where timing critical IP can be isolated away from non-critical IP. For example, a group of low bandwidth IP can be placed on a slower clock, smaller data width AXI Interconnect to free up logic and congestion from the higher performance IP running at higher clock rates and wider data paths.
5. Separate IP using register slices then floorplan the IP blocks (this is an advanced strategy). After placing register slices to provide timing isolation, IP blocks can be floorplanned further away from the interconnect core to reduce congestion around that block core.

Throughput and Bandwidth Optimization Guidelines

1. Increase clock frequencies using timing optimizations described in ["Timing and Fmax Optimization Guidelines,"](#) in the previous section. Increasing clock frequency, such as

through the use of register slices to break long combinatorial paths can improve overall bandwidth.

2. Increase data path widths. Wider data paths carry more information per clock cycle.
3. Turn on data path FIFO buffers. Buffers can provide elasticity to hide temporary stalls or backpressure in the data flow. Use of the additional block RAM FIFO option, to delay `AWVALID`/`ARVALID` until FIFO occupancy permits interrupted burst transfers, can further improve throughput at the expense of increased latency.
4. Segment interconnects to group high performance IP together and place lower performance IP in a separate interconnect. Isolating high performance IP into a smaller subsystem permits greater flexibility to optimize that subsystem for higher throughput.
5. Increase transaction burst length. Longer bursts reduce the potential for stall cycles caused by address arbitration and control logic overhead.

Longer bursts also signal to the AXI slave the intent to move a large amount of contiguous data so that slaves, such as memory controllers, can better optimize their response, and Reduce the relative amount of AXI address channel bandwidth.

This reduces address channel congestion around the shared address arbiter logic in the AXI Interconnect.

6. Increase transaction pipelining including issuance and acceptance. Pipelining transactions allows arbiters and control logic in the slaves to work ahead on the next transaction while completing a previous transaction. This helps to reduce stalling due to arbitration/control cycles between back to back transactions.
7. Exploit parallelism of Sparse Crossbar AXI Interconnect. In Sparse Crossbar Mode, the AXI Interconnect supports parallel data flow when multiple masters transfer data to multiple independent slaves.
8. Avoid issuing read/write address requests until the IP ensures it can provide data while inserting minimal idle cycles in the data stream. Otherwise when a read or write data transfer is in progress, stalling the data phase of the transaction could prevent the AXI Interconnect from servicing other read or write data transfers. If the master or slave stalls, it could be blocking other devices, limiting system throughput.

For higher throughput, design IP to request reads or writes when they are ready to be serviced with minimal stall cycles. The use of buffering might be beneficial. The worst case is a very slow AXI master requesting write bursts. When the slow master is granted arbitration, it will block other writes to the same slave until it completes its slow write transaction; this can take many clock cycles to transfer each beat of data.

The use of data path FIFOs (with delayed `AWVALID`/`ARVALID` feature) in the AXI Interconnect can help mitigate the system throughput impact of slow masters.

Latency Optimization Guidelines

1. Minimize clock and width conversions. Clock and width conversion require logic that adds additional cycles of latency.
2. Avoid using AXI3/AXI4 narrow bursts. Some AXI slave devices such as memory controllers must use logic to internally convert narrow bursts to full width bursts. This packing logic adds latency. If all masters connected to a given slave can designate that they do not perform narrow bursts, the narrow burst logic in the slaves can be disabled, thereby reducing area and latency.
3. Increase arbitration priority of latency sensitive masters. If some masters are more latency sensitive than others, increasing the priority of the latency sensitive master helps its requests to be serviced more quickly.
4. Reduce transaction burst lengths to prevent prolonged head of line blocking. Long bursts lengths can tie up data paths for longer periods of time while latency sensitive masters have to wait. Reducing burst length provides more frequent arbitration cycles where a latency sensitive master can gain access.
5. Increase clock frequency while trying not to using register slices. This reduces the absolute latency time. If register slices are not added, the number of clock cycles of latency does not change, only the period of each clock cycle.
6. Control Issuance/Acceptance of pipelined transactions from competing IP that are not latency sensitive. Head of line blocking can be introduced by high numbers of pipelined transactions. By limiting issuance/acceptance, the number of pipelined transactions is limited so that there are fewer potential transactions pipelined ahead of a latency sensitive transaction.
7. Arrange system address map and address access patterns to exploit row/bank management features of AXI DDRx (MIG) memory controllers.

Accessing address locations of open banks and rows (pages) of memory reduces DRAM memory access time.

8. Exploit parallelism of crossbar AXI Interconnect/AXI SmartConnect or segment interconnects to reduce congestion and shorten path from latency critical master to slave. They can be segmented, grouped, and optimized to arrange the latency sensitive masters closest to the slaves they wish to access.

Ease of Use and Debug Optimization Guidelines

1. Greater ease of use is accomplished by leaving each IP in its native, most convenient clock, width, and protocol, and using the per-port configurability of the Interconnect to adapt to the IP.
2. Using full crossbar connectivity provides more flexibility to change active transaction source and destinations, whereas sparse connectivity limits the flexibility of which masters can communicate with which slaves.



TIP: *An even simpler solution is to use the Shared Address Shared Data (SASD) mode of the AXI Interconnect.*

SASD mode permits only a single read or write transaction to execute at a time with no overlapping or pipelining of transactions. The SASD mode of the AXI Interconnect stalls transactions so only a single one at a time can progress. This eases the debug and understanding of transaction sequences.

3. The AXI4-Lite protocol is much simpler than the AXI3 or AXI4 protocol. If AXI4-Lite is sufficient for an IP, using it simplifies the design.
 4. Reducing the use of threading and transaction pipelining makes the system easier to debug and analyze using the AXI debug monitor. Threading and pipelining make it more difficult to correlate activity on each of the AXI channels with a logical transaction. High levels of threading and pipelining also might be more likely to expose functional bugs in user IP.
 5. Enabling the AXI debug monitor permits full waveform capture and triggering in hardware. This enables hardware runtime viewing/triggering of some or all AXI signals. This can be used to help diagnose functional or performance issues in hardware.
 6. AXI hardware protocol checkers also help detect and more quickly isolate the source of protocol violations due to functional errors.
-

AXI4-based Vivado Multi-Ported Memory Controller: AXI4 System Optimization Example

AXI4 Vivado MPMC Overview

You can create an AXI4-based Multi-Ported Memory Controller (AXI MPMC) using a combination of an AXI Interconnect and an AXI memory controller core. This permits multiple AXI4 masters to share a common physical memory.



IMPORTANT: This section provides system optimization examples using AXI Interconnect IP, but the same techniques apply to the SmartConnect IP too.

The Interconnect can be configured in an N Master to 1 Slave mode with AXI MIG as the slave connected to the AXI Interconnect as shown in the following figure.

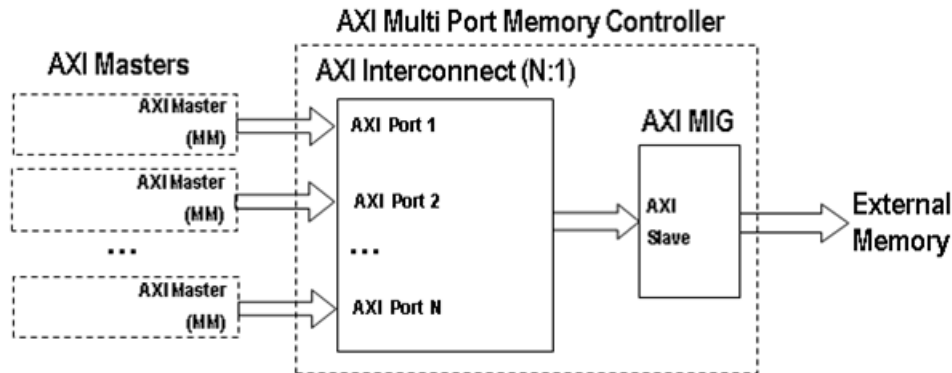

Figure 6-1: AXI4 MPMC Block Diagram

IP Configuration decisions across AXI masters, the AXI Interconnect, and AXI MIG can greatly affect the characteristics of the system, such as size, F_{max} , throughput, and latency. By using the general optimization information described previously, the AXI MPMC can be tuned for a balance of size and performance. This section works through an example of applying system optimization techniques to tune the AXI MPMC.

For information on how to create an AXI MPMC design using the Vivado® Integrated Design Environment (IDE) IP integrator, see the *7 Series FPGAs AXI Multi-Ported Memory Controller Using the Vivado IP Integrator Tool* (XAPP1164) [Ref 45].

For an example of an AXI MPMC used in a high performance system, see *Designing High-Performance Video Systems with the AXI Interconnect*, (XAPP740) [Ref 44].

Initial Memory Controller Configuration

Assume the AXI MPMC is used for the purpose of transferring multiple data streams to and from a common physical memory. The first step is configuring the memory controller to meet the bandwidth requirements of the system.

The AXI MIG supports physical memory widths of 8, 16, 32, 64, and 128 bits wide with a memory clock rate of 300 to 400 MHz for a -1 speed grade Virtex®-6 device (check MIG documentation for other clock and width limitations). This equates with a 600 to 800 MHz data rate on the physical data lanes.

Assume that four AXI masters are required, each consuming up to 100 MBytes/sec of bandwidth for reads and 100 MBytes/sec of bandwidth for writes with a native 32 bit x 48 MHz AXI4 interface.

This implies $4 \times 2 \times 100 \text{ MBytes/sec} = 800 \text{ MBytes/sec}$ of total bandwidth is required.

For the memory controller configuration options, the following table can be derived:

Table 6-3: Memory Controller Configuration Options

Physical DDR3 Data Width (Bits)	Memory Clock (MHz)	Data Rate (MHz)	Max theoretical Bandwidth (MBytes/sec)
8	300	600	600
8	400	800	800
16	300	600	1200
16	400	800	1600
32	300	600	2400
32	400	800	3200
64	300	600	4800
64	400	800	6400
128	300	600	9600

The two smallest memory configurations that would meet the bandwidth requirements of the system are using a 16-bit DDR3 running 300 to 400 MHz memory clock rate, providing 1200 to 1600 Mbytes/sec of theoretical bandwidth (67% to 50% memory utilization at 800 Mbytes/sec).

In theory an 8-bit DDR3 running at 400 MHz meets the bandwidth also, but given overhead (lost clock cycles) for refresh, write-leveling, read-write bus turnaround time, and row/bank address changes, some more efficiency margin is required.

With AXI MIG, the AXI slave interface data width is natively equal to four times the physical memory data width and the AXI slave clock is $\frac{1}{2}$ the memory clock frequency, so a 16-bit DDR3 @ 300 to 400 MHz directly corresponds to an AXI slave interface that is natively 64-bits wide at 150 to 200 MHz.

Initial AXI Interconnect Configuration

To be able to consume all the bandwidth from the memory controller, the AXI Interconnect core must be have at least the same bandwidth as the memory controller. Given the recommendation to avoid width and clock conversion that impact size and timing, the interconnect core and slave side port should be configured as 64-bits at 150 to 200 MHz to match the native AXI interface of the memory controller.

To configure the master side of the AXI Interconnect, note that the AXI master is natively 32 bits at 48 MHz. This requires a 32- to 64-bit size conversion for each master.

In addition, the 48 MHz AXI clock on each AXI master would result in an asynchronous clock conversion if the interconnect is running at 200 MHz.

Clock Conversion Recommendation

The recommendation for clock conversion is to use synchronous ratios over asynchronous ratios to reduce logic.

Instead of a 200 MHz Interconnect clock, the system can be configured to attempt to remove asynchronous clock conversions by employing a:

- 48 MHz AXI master clock
- $48 \times 4 = 192$ MHz AXI Interconnect clock
- $192 \times 2 = 384$ MHz memory clock

Note: The 48, 192, and 384 MHz clocks should be driven by the same Mixed Mode Clock Manager (MMCM) block to be phase aligned.

The following figure shows an example of the AXI Interconnect master side configuration.

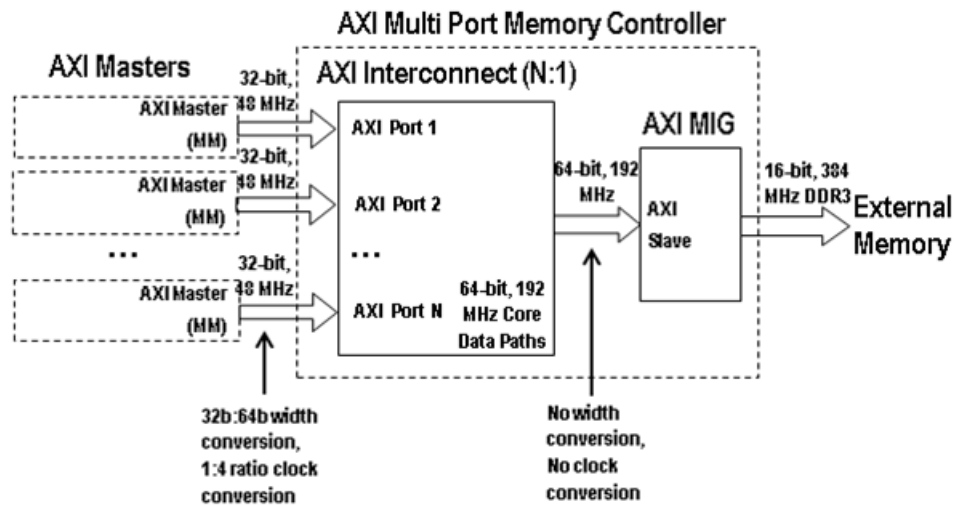

Figure 6-2: AXI Interconnect Master Side Configuration Block Diagram

AXI4 Master Configuration

The use of AXI4 transactions by the AXI4 master impacts the performance that can be obtained from the memory controller and system. Because this system requires significant bandwidth from the memory controller, maximizing the burst length of AXI4 transactions to 256 beats helps improve overall data bandwidth.

Maximize Burst Length

Longer bursts reduce address arbitration/control cycles and help keep the memory controller in the same row, bank, and read/write direction longer. Long bursts would normally impact latency, but assuming this application is not very latency sensitive and that data path FIFOs are enabled for elasticity, the use of long bursts should not result in head of line blocking/stalling.

No Narrow Burst Transactions

The AXI4 master should not issue any narrow burst transactions. Narrow bursts are defined in the AXI specification as transactions where the size of the AXI transaction is more narrow than the native data width of the interface. Such bursts are less efficient in terms of bus utilization and require extra logic in the memory controller to handle repacking of any narrow bursts into full width bursts.

In this example:

- Size AXI transactions issued by the masters to 32-bit (`AXSIZE = 0x2`).
- Enable the modifiable bit on AXI transactions (`AXCACHE[3]=1`) to ensure that any downstream upsizer can fully pack data up to wider widths. This allows costly narrow burst support logic to be removed from the memory controller.

In the IP integrator, this is designated by the `C_SUPPORTS_NARROW` parameter that then allows the IP integrator to automatically configure AXI MIG to omit narrow burst support logic. From the context of the CORE Generator™ tool, you must manually configure AXI MIG to omit narrow burst support logic.

Pipeline Transactions

Design the AXI4 master to pipeline transactions so it can issue new address requests while servicing the data transfers for previous transactions. Pipelining transactions helps overlap address and control cycles with data transfer cycles to improve data path efficiency and throughput. However, new address requests should not be made until it is ensured that the master can supply sufficient write data or has sufficient ability to accept read data to complete a full burst with minimal stalling. A master that issues an address request and excessively stalls the data transfer phase of its requested transaction could cause backpressure that could eventually stall or slow the whole system.

Single Thread Transactions

Design the AXI4 master so that it operates using only a single thread for all transactions (declared using the `C_SUPPORTS_THREADS=0` parameter). By not using multiple threads, the logic in the AXI4 master can be simplified because it can be designed to rely upon write responses and read data being returned in order. The use of a single thread also benefits the AXI Interconnect performance because the upsizer is active in this example system.

Upsizers in the AXI Interconnect stall when changing ID threads so using a single thread avoids stalling of transactions passing through the upsizer. Ensure that the AXI4 master declares itself not to use threads so that AXI Interconnect can be configured to omit its multi-thread support logic which reduces area and improves timing. Using a single thread also makes debug easier because AXI transactions observed in the lab tool monitor are easier to decode and correlate across a system.

Refining the AXI Interconnect Configuration

After a first pass to establish the basic configuration of AXI MIG, AXI Interconnect, and the AXI4 master of the user, the user can then perform a second pass at refining the AXI system configuration.

Independently Configure Converter Banks

When fine tuning the configuration of the AXI Interconnect, it is useful to understand the AXI Interconnect converter bank block. The converter bank handles size, clock, and protocol conversion in addition to register slice and data path FIFO features.

The converter bank can be independently configured at each endpoint of the AXI Interconnect, as shown in the following figure.

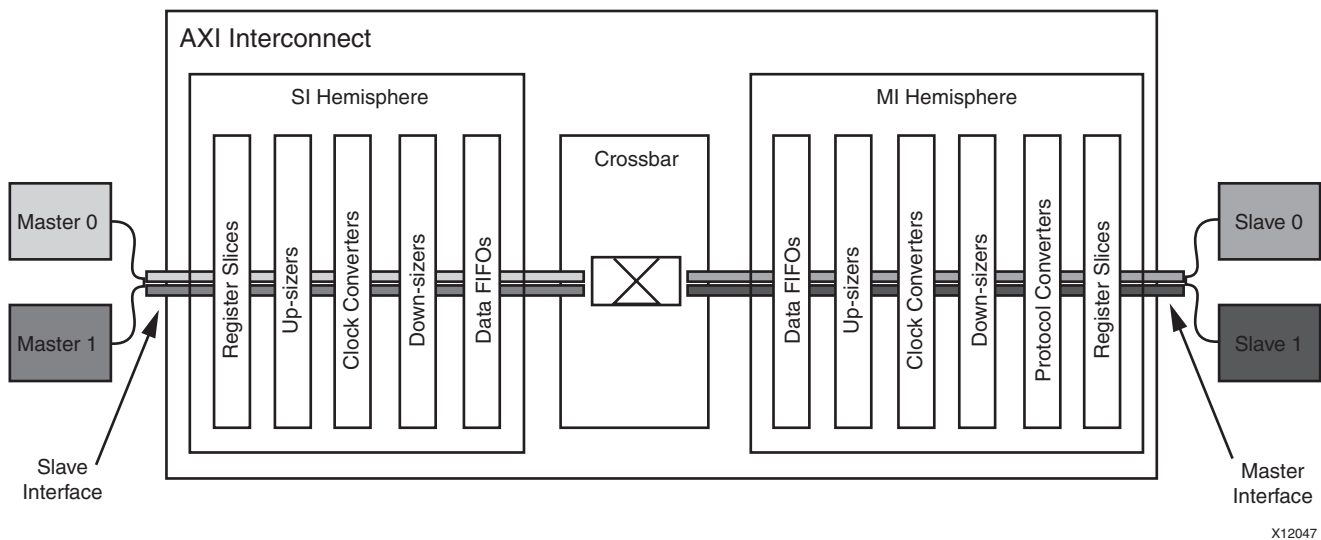

Figure 6-3: AXI Interconnect: Crossbar Block Diagram

Notice that from the perspective of the attached AXI master, shown in the previous figure, the data path FIFOs are positioned after the upsizer and the clock converter so that the FIFO interfaces to the interconnect core at its higher native width and clock.

Because the AXI masters are at a relatively lower bandwidth than the memory controller (1/2 width, 1/4 clock frequency), turning on data path FIFOs allows the interconnect to buffer

up the wider width transactions to and from the memory controller and service each of the AXI masters at their slower rates on the other side of the FIFOs.

Datapath FIFOs reduce stalling of the memory controller due to the slower data rate AXI masters. The AXI Interconnect offers data path FIFOs in options of 32 deep or 512 deep FIFOs. Because the AXI4 master is generating long bursts up to 256 beats in length, configure the FIFOs as 512 deep to fit an entire burst.

The data path FIFOs have an optional feature, called *Packet Mode*, to delay `AWVALID/ARVALID` until FIFO occupancy permits interrupted burst transfers downstream.

The Packet Mode feature:

- Causes write address requests to be withheld from the crossbar until the write data path FIFO has buffered all the data for the transaction.
- Causes read address requests to be withheld from the crossbar until the read data path FIFO has sufficient vacancy to store the entire transaction.
- Ensures that the crossbar does not see a transaction request until the data path FIFO can guarantee that it can source/sink the entire transaction at the full bandwidth of the crossbar without introducing stall cycles in the data transfer.
- Is especially useful in situations similar to the example design, shown in [Figure 6-2](#), where the master has a relatively lower bandwidth than the slave (memory controller).

Timing Considerations

For timing, the AXI Interconnect should be configured to enable register slices at the interface to the memory controller. Because the AXI interface memory controller operates at the highest width and clock frequency in the system, it is likely a critical path unless a register slice is turned on.

A Type 8 register slice can be enabled on all five channels at the AXI interface of the memory controller to allow the AXI Interconnect to optimize the kind of register slice best suited to each AXI channel.

Note: A register slice at the AXI master interface is not required. This is because the AXI master and the upsizer are both clocked by the slower 48 MHz side of the clock converter.

Also, the clock converter acts as a register slice because it provides timing isolation between 48 MHz and 192 MHz clock domains.

Setting Issuance and Acceptance Values to 2 or Higher

Issuance and acceptance values at each port of the AXI Interconnect can be optimized to support transaction pipelining and to limit the pipelining so that head-of-line blocking is reduced. The default issuance assigned to an AXI masters is 1, unless configured or designated otherwise. An issuance of 1 minimizes logic but does not permit transaction pipelining. Set the issuance to a value of 2 or higher.

Because the target system seeks to maximize throughput, you can calculate the maximum number of outstanding transaction possible without overflowing the data path FIFOs. The data path FIFOs are 64 bits wide x 512 deep as described above. That is equivalent storage to 32 bits wide x 1024 deep.

If the AXI4 master is generating AXI transactions of maximum length 256, then up to four transactions fit into the data path FIFOs.

The AXI Interconnect supports issuance and acceptance values of 1,2,4,8,16, and 32. Reasonable values of issuance for each AXI master would therefore be 2 or 4.

- Given that there are 4 masters, an issuance of 2 means that memory controller would need an acceptance of 8 to fully pipeline 2 transactions from each master.
- Given that transactions are all long bursts, pipelining more than 8 transactions at the memory controller becomes excessive. An issuance setting of 4 at the masters is too high because it would require the slave to consume up to 16 transactions to utilize.
- Given that master issuance of 4 might be excessive while an issuance of 1 prevents transaction pipelining, a setting of 2 is reasonable.

Adding a Processor to the AXI MPMC System

Adding a processor to the example AXI MPMC system complicates the optimization of the system because processors tend to be very latency sensitive with respect to their performance. If the processor must also share the memory controller to run complex software such an operating system or protocol stack, you must take more care to balance the low latency requirements of the processor with the high throughput requirements of the other AXI masters.

Processor traffic could interfere with other devices resulting in reduced throughput from other masters. This is due to random memory accesses that disrupt the row/bank access patterns of the other devices and because the processor can generate a number of small length transactions. Small length transactions corresponding to 4- or 8-word cache lines can consume several memory clock cycles for row/bank access time, read/write turn around, and so forth. Therefore, the actual data bandwidth transferred by the processor might be small, but because they can disrupt the otherwise linear, long burst access patterns of the memory controller, their traffic actually displaces a much larger amount of the theoretical system bandwidth.

For example, 10 Mbytes/sec of delivered data bandwidth to the processor, might actually displace the equivalent of 100 MBytes/sec of the theoretical bandwidth of the memory controller. Optimizations to improve processor performance could force a trade-off in system throughput, further eroding the bandwidth available to other masters.

Considerations When Adding a Processor

If you need to add a processor to the system, you must consider:

- If the memory width or clock should be increased to provide more available margin.
- Whether to reduce the burst length of the other AXI masters to reduce the time that a processor waits for a burst transaction to complete.
- If the highest arbitration priority can be granted to the processor to minimize its latency.
- If the issuance/acceptance values for other devices might be reduced to limit head of line blocking due to pipelined transactions.
- If the system clocking can be altered to favor the memory path of the processor having no clock conversion or only synchronous clock conversion.

Note: The MicroBlaze™ processor can support a native 128-bit and 256-bit and 512-bit wide AXI interface. This is an example of application domain size conversion that is more efficient than generic AXI width conversion. This MicroBlaze wide cache configuration is ideal for connecting to an equally wide memory controller to remove the latency impact of size conversion.

The optimizations described to improve processor performance are often the opposite step for maximizing system throughput.

Therefore, either more margin is needed by using a larger memory controller or you must carefully optimize your software (to minimize cache misses) and be more willing to experiment with the system to find the right balance between latency and throughput.

Additional Potential Optimizations for AXI MPMC

The previous AXI MPMC optimization information steps through an example of working through the design optimization process, while attempting to balance tradeoffs between various design criteria.

The following subsections describe further optimization ideas than might be applicable. These optimizations might or might not be suitable for a given AXI MPMC design and could require experimentation to see if the technique is useful in a given situation.

AXI Interconnect: Shared Address Shared Data Mode

If there is enough extra unused bandwidth, the AXI Interconnect can be configured in Shared Address Shared Data (SASD) mode.

In this mode, the AXI Interconnect core is simplified to operate on only a single read or a single write at a time and even shares read and write addresses over the same wires.

This mode removes support for pipelined transactions and prevents simultaneous read and writes, but significantly reduces logic. Given that long bursts are used, the penalty of stall cycles between transactions and lack of simultaneous read and write data flow might be acceptable within the bandwidth requirements of the system. SASD also makes system debug and waveform analysis of AXI transactions substantially easier. SASD is also generally more lenient about functional bugs and protocol violations from endpoint IP.

Separate IP Groups into Separate AXI Interconnect Subsystems

If an AXI MPMC design has many masters, and the design has difficulty meeting timing, one possible strategy is to group two or more IP into a separate $N \times 1$ AXI Interconnect that then feeds the main AXI Interconnect. This breaks a wide fan-in Interconnect into multiple smaller fan-in Interconnects. Each smaller Interconnect is easier to route and meet timing, and also provides a greater range of options for the location of register slices, FIFOs, size, clock, and width converters.

For example, when two AXI Interconnects connect directly to each other, a set of back-to-back register slices can be enabled using one register slice from each adjacent interconnect. This can be used to span longer routing distances in large AXI MPMC systems.

In some cases using multiple AXI Interconnects can even reduce overall system size.

When an AXI MPMC requires a large number of upsizers, especially with large steps like 32- to 128-bits, separating the masters into subgroups using smaller width AXI Interconnects can reduce the number of upsizers which consume area and impact timing.

Debug and Analysis: Using AXI Debug Monitor and AXI Hardware Protocol Checkers

The Vivado AXI lab tool debug monitor is a feature that provides waveform capture and triggering of AXI interface signals in hardware. The AXI debug monitor can be used to help debug functional issues in hardware or to help diagnose performance issues.



IMPORTANT: *Analyze Complex System Activity.*

You can place multiple AXI debug monitors around the system and cross-trigger between each of them to analyze more complex system level activity. The AXI Hardware Protocol

Checker feature is available that can trigger the AXI debug monitor when some types of AXI protocol violations occur.

The AXI Hardware Protocol Checker can more quickly isolate the source of protocol violations. For more information, see the *LogiCORE IP AXI Protocol Checker: Product Guide for Vivado Design Suite* (PG101) [Ref 15].

Floorplanning

AXI IP connected to the AXI Interconnect can be floorplanned to improve placer results and reduce routing congestion. To make floorplanning easier in large FPGAs, enable extra register slices to provide a more distinct flip flop-based boundary at the AXI IP interface.

Note: After any significant changes to the AXI Interconnect configuration, floorplan locations might need to be rechecked and updated as necessary. Otherwise subsequent changes to the AXI Interconnect, such as turning on data path FIFOs, can change the footprint and necessary placement of the AXI Interconnect.

AXI Verification IP

The Vivado IP integrator supports instantiation of AXI Verification IP (AXI VIP) and AXI Protocol Monitors for use in simulation to exercise and test AXI IP.



RECOMMENDED: *Xilinx recommends that you use AXI Verification IP for verification of user IP under development. Given the potential complexity of understanding AXI transactions, especially across pipelined transactions and multi-threaded traffic, it can be extremely difficult to debug subtle functional errors or isolate the root cause of protocol violations solely in hardware. The simulation domain is usually a far less expensive method for verifying and debugging new AXI IP before use in complex systems.*

See the *LogiCORE IP AXI Verification IP Core Product Guide for Vivado Design Suite* (PG267) [Ref 26] for more information.

More Simple but Wider Interconnect and Memory Controller

Another potential strategy for an AXI MPMC system is to oversize the width of the memory controller and AXI Interconnect core, such as by doubling the memory width to double the theoretical system bandwidth. By adding extra potential system throughput, the configuration of the rest of the system is much more simple.

For example, a system initially requiring a 16-bit DDR3 at 400 MHz with the AXI Interconnect core configured as 64-bits at 200 MHz could be reconfigured with a 32-bit DDR3 at 300 MHz and an AXI Interconnect configured as 128 bits at 150 MHz.

The extra bandwidth from doubling the physical memory width can be used to allow greater system simplifications, including:

- Reducing AXI clocks from 200 MHz to 150 MHz to improve timing:
 - Reductions in clock frequency could permit register slices to be turned off
 - Reductions in clock frequency could permit use of a slower speed grade FPGA device
- Allowing the crossbar to be reconfigured into SASD (this disables transaction pipelining and multi-threading support):
 - Simplifies system debug
 - Provides room for future system bandwidth expansion (you can later increase clock frequencies, enable crossbar, and so forth.)
- Allowing masters to use shorter burst lengths:
 - Reduces latency or reduces system FIFO/buffering requirements

Note: Increasing memory controller and AXI Interconnect data width could introduce new size conversion requirements and board-level requirements into the system that might offset these AXI system simplifications so analysis and experimentation is required to determine if this approach is an overall improvement for the given application.

Cascading Interconnects

In some situations where the AXI Interconnect is a large Nx1 configuration with upsizing, width conversion, with enabled data path FIFOs, it might be beneficial to deploy multiple cascaded interconnects instead of a single large Interconnect. This is often the case in high performance systems that contain high bandwidth memory controllers shared by multiple lower bandwidth masters.

For example, consider an AXI MPMC with 8 masters each with 32 bit at 100 MHz interfaces connected to a memory controller with a 256 bit interface at 200 MHz as shown in the following figure. Assume that each master requires 70% of the available bandwidth of the interface:

$$32 \times 100 \times 0.7 = 2240 \text{ mbits/sec.}$$

Equation 6-1

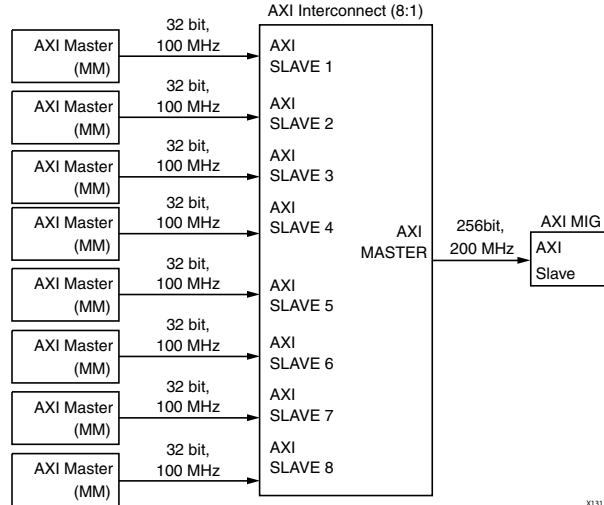

Figure 6-4: AXI MPMC with 8 Masters

For highest performance, the interconnect would enable 32 to 256 bit upsizing, 100 MHz to 200 MHz clock conversion, and Packet Mode data path FIFOs as shown in the following figure.

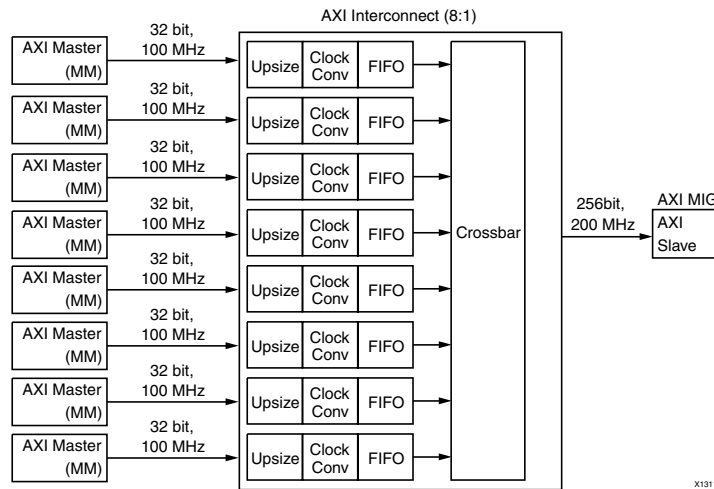

Figure 6-5: Enabled Upsizing

The order of the sub-modules in the interconnect is:

Upsizer followed by Clock Converter followed by FIFO

This ordering is also shown in Figure 6-3 as the architecture of the AXI Interconnect.

Note: The clock converter and FIFO are located after the upsizer, therefore each block essentially contains a 256 bits wide internal data path for read and write channels.

As a rough estimate, assume this that each sub-module uses two FFs and two LUTs per data path bit. The approximate size of the data path logic used by the converter blocks is estimated with the following equation:

$$\text{Size (LUTs and FF)} = \langle \text{number of ports} \rangle \times \langle \text{number of sub-modules} \rangle \times \langle \text{data width in bits} \rangle \times \langle \text{number of LUTs and FFs per bit} \rangle$$

Equation 6-2

or

$$8 \text{ ports} \times 3 \text{ sub-modules} \times 256 \text{ bits datapath} \times 2 \text{ channels for read/write} \times 2 \text{ LUTs and FFs per bit} = 24576 \text{ LUTs and 24576 FFs.}$$

Equation 6-3

It can also be assumed that generally the size of the datapaths dominates as the percentage of the total size of the interconnect relative to the size of the control path logic.

An alternative implementation of the design to explore is to use two levels of cascaded Interconnects to partition the design into multiple smaller, more gradually scaled Interconnect building blocks as shown in the following figure.

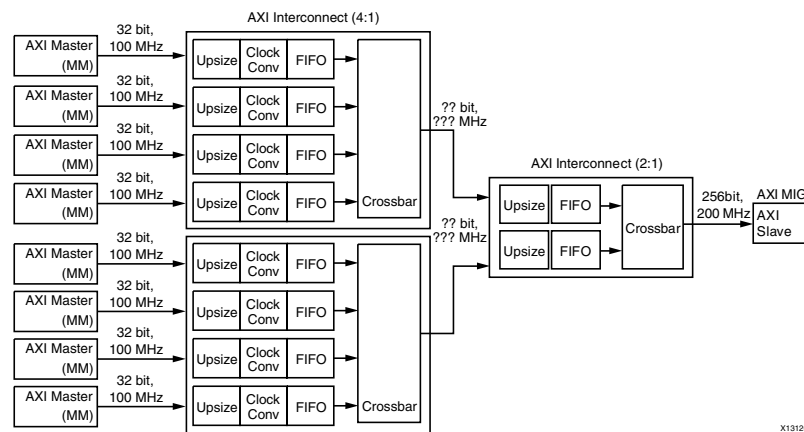

Figure 6-6: 4x1 Interconnect and 2x1 Interconnect

The scaling, shown in Figure 6-6, is 4x1 Interconnect + 4x1 Interconnect followed by a 2x1 Interconnect that uses three smaller Interconnect blocks instead of one large block.

This is likely a more optimal design than a 2x1 Interconnect + 2x1 Interconnect + 2x1 Interconnect + 2x1 Interconnect design followed by 4x1 Interconnect because it uses five blocks and therefore, is more likely to lead to optimal partitioning than the one shown in Figure 6-5.

Using the partitioning shown in the following figure, the next step is to find the best size and width for the intermediate interface between the cascaded interconnects.

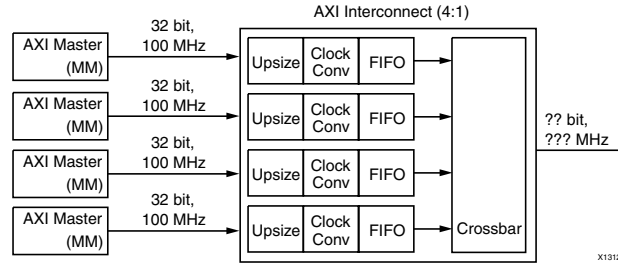

Figure 6-7: Partitioning for Best Size and Width

The options are:

- Width can be 32, 64, 128, or 256 bits wide.
- Clock frequency is either 100 or 200 MHz (to avoid the use of asynchronous clock converters).

The choice of intermediate signal width and clock frequency determine where width converters and clock converters are placed in the system and what their data path sizes are.



IMPORTANT: Assume that Packet Mode data path FIFOs are required in all Interconnects because that is needed to ensure there are no bottlenecks in the data flow toward the memory controller.

Each 4x1 Interconnect aggregates traffic from four masters each requiring 70% of the bandwidth of the 32 bits x 100 MHz interface for a total maximum throughput requirement of
 $4 \times 32 \times 100 \times 0.7 = 8960$ mbits/sec.

By looking at the maximum throughput of the connections as detailed the following table, some options can be eliminated because the given intermediate interface configuration cannot support this aggregate throughput requirement.

Table 6-4: Maximum Connection Throughput

Width (Bits)	Clock Domain (MHz)	Raw Throughput (mbits/sec)	Capable of 8960 mbits/sec
32	100	3200	No
32	200	6400	No
64	100	6400	No
64	200	12800	Yes
128	100	12800	Yes
128	200	25600	Yes
256	100	25600	Yes
256	200	51200	Yes

Table 6-5 shows the results of using Equation 6-2 for estimating the size of the interconnect sub-module data paths, for each intermediate interface option that offers sufficient throughput.

Table 6-5: Interconnect Size by Width and Clock Domain

Width (Bits)	Clock Domain (MHz)	Size Estimate
64	200	10240
128	100	14336
128	200	16384
256	100	20480
256	200	26624

Therefore, if the intermediate interface is configured as 64 bits x 200 MHz, the data path area for the cascaded scaled Interconnects is estimated at 10240 LUTs/FFs compared to 24576 LUTs/FFs used by the original single Interconnect design.



TIP: Cascading Interconnects reduces area and potentially improves timing through reduced routing congestion, but there is a trade-off in higher system complexity and higher latency.

The following figure shows the optimized system configuration.

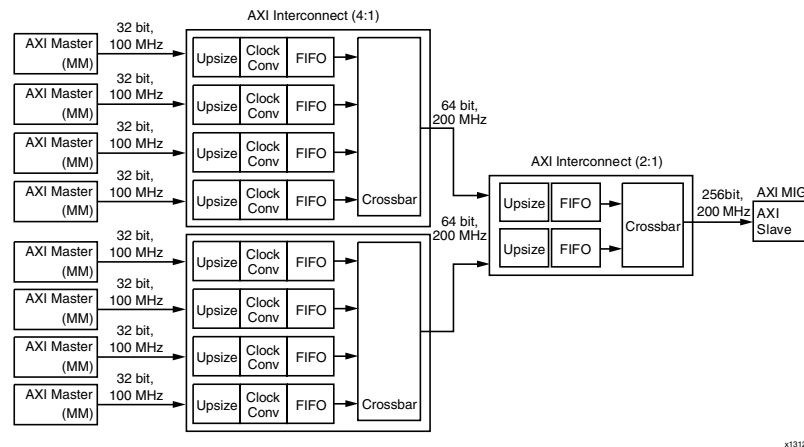

Figure 6-8: Optimized System Configuration

Using this approach of estimating the size of scaled Interconnects and removing unfeasible options, you can narrow down the choices to experiment with cascaded Interconnects to further reduce area.



IMPORTANT: Verify any estimates through implementation of the complete system to validate the improvement.

Common Pitfalls Leading to AXI Systems of Poor Quality Results

This section describes common pitfalls designers might encounter leading to the design of AXI systems that are of a larger than expected area, have poor performance, or have poor timing.

Oversizing a Memory Controller

AXI Virtex-6 MIG supports DDR3 physical memories in 8, 16, 32, 64, and 128 bit widths, which translates into a 4 times wider native AXI data width of 32, 64, 128, 256, and 512 bits wide.

If a system contains only a 32-bit microprocessor and associated AXI4-Lite peripherals, then connecting it to a 64-bit physical DDR3 memory is wasteful of logic and would actually degrade performance.

Such an AXI MIG would have very large area for the physical interface logic and the 256 bit data paths inside the AXI MIG. Also, the native 256-bit AXI interface would have to be upsized from the 32-bit AXI interface of the processor adding further area and latency.



IMPORTANT: *Size the AXI MIG to meet the bandwidth needs of the system while minimizing unnecessary size conversions.*

This situation can be common when using fixed evaluation boards, like the ML605, that contain a 64-bit DDR3 DIMM. You might be working from a reference design containing an AXI MIG configured for a full, 64-bit DDR3 DIMM that is oversized for a simple MicroBlaze™ processor application.

Incorrect Core Data Width or Core Clock for AXI Interconnect

Incorrectly setting the core data width or connecting the wrong core clock to the AXI Interconnect can severely impact the system.

For example, consider a system with five masters and five slaves connected to AXI Interconnect. Assume that each master and slave is 64-bits wide at 100 MHz.

If the AXI Interconnect is also configured to be 64-bits wide at 100 MHz, then no clock or width converters are used. However, if the interconnect core data width is accidentally configured to be 32-bits wide at 75 MHz, then the same system would then need to incur a 64:32 bit downsizer for each master, a 32:64 bit upsizer for each slave and asynchronous clock converters at every master and slave. The extra cost of 10 size converters and 10 asynchronous clock converter results in poor timing, very large area, and very high latencies in the system.

Additionally, the throughput in the system is greatly constrained because wide 64-bit AXI traffic from the masters and slaves are funneled through a much more narrow and slower 32-bit data path in the AXI Interconnect. This would result in stall cycles between every data beat the masters and slaves are trying to transfer.



TIP: *Watch For Wrong Clock and Interconnect Data Widths.*

Because the Vivado IP integrator handles width and clock conversion configurations automatically, connecting the wrong interconnect clock or setting the wrong interconnect data width causes the IP Integrator to automatically activate all the necessary conversions to make the system function. The result is a system that might appear to function and completes all AXI transactions, but the system bandwidth, area, latency, and timing could be very undesirable.

Overuse of Register Slices

In general, register slices are useful for helping to close timing in a system. However, excessive use of register slices can be counterproductive.

For example, enabling all register slices on all AXI interfaces in a large system might increase the area of a system leading to routing congestion and longer map, place, and route times while not improving timing.



TIP: *Incrementally Add Register Slices.*

The recommended approach is to incrementally add register slices when timing fails starting at the interfaces with highest clock frequencies and data widths. Register slices might also be needed for large crossbar interconnects or at AXI interfaces where size conversion is performed. If large numbers of register slices are required to meet timing in a large system, floorplanning might be needed to help guide the place and route tools.



TIP: *Do Not Place Register Slices on AXI4-Lite IP.*

Generally, Xilinx recommends that you do not place register slices on AXI4-Lite IPs.

The recommended approach is to segment AXI4-Lite IP onto a separate SASD AXI Interconnect and clock this AXI Interconnect and its attached AXI4-Lite IP at a slower common clock frequency to better meet timing.

If timing improvement is needed on an AXI4-Lite Interconnect, first enable the special internal register slice rank inside the SASD Interconnect; then add register slices only on specific channels of AXI4-Lite IP that fail timing.



TIP: *Watch For Wrong Register Slice Types.*

Also, using the wrong type of register slice can lead to undesirable effects.

For example, type 1 register slices support back-to-back data beats without inserting stalls while type 7 register slices use less area, but insert a stall after every data transfer.

- The type 7 register slice is ideal for AXI4-Lite interfaces or for AW, AR, and B channels of an AXI interface where back-to-back transfers do not occur or occur infrequently.
- The type 1 register slice is designed for R and W channels where burst transactions occur.
- For convenience, a type 8 register slice option is provided which automatically switches between type 1 and type 7 based on the AXI Interconnect configuration. Type 8 is recommended and should only be overridden when specifically warranted.

Skipping Simulation-Based Verification of New IP

AXI4 provides a rich protocol that can:

- Scale into more complex systems
- Support sophisticated protocol features such as multi-threading and transaction pipelining
- Manage transaction ordering and completion rules to manage traffic among multiple AXI masters and slaves in a system.

The richness of the AXI protocol and the possible concurrency of data transfer in a crossbar, make hardware-only based debug and verification of new AXI IP much more challenging.



RECOMMENDED: *Verify new IP in simulation using AXI VIP available for the Vivado IP integrator.*

Simulation-based verification results in far shorter debug cycle time, easier identification and isolation of functional problems, and greater variation of AXI traffic than hardware-only based verification.

Hardware-only based AXI IP verification requires full synthesis and Place and Route (PAR) time per debug cycle, and the visibility of signals from an AXI debug monitor is more limited than in a simulation domain. The potential complexity of AXI4 traffic even in a relatively typical system makes hardware-only verification very expensive.

However, if you must rely on hardware-only AXI IP verification, Xilinx recommends that the AXI Interconnect be configured as simply as possible.

For example, use SASD (which limits issuance/acceptance to 1), and minimize the use of converter bank functions (size conversion, clock conversion, data path FIFOs, and so forth). Register slices can also be enabled for hardware-only verification because register slices acts as a filter for traffic patterns that can insulate the system from some protocol violations.

Enable AXI debug monitors and hardware protocol checkers at strategic points in the system when performing hardware-only verification.

Non-contiguous Mapping of Slave Devices in Cascaded Interconnect Scenarios

Instances of AXI Interconnect can be cascaded, allowing masters attached to an upstream interconnect to send transactions to slaves on one or more downstream interconnects.

Cascading lets you optimize the flow of data the system by attaching peripherals with similar system characteristics to specific interconnect instances.

When AXI interconnect instances are cascaded, an upstream interconnect must perform enough address decoding to route transactions from the master to the correct downstream interconnect.



IMPORTANT: *If the downstream interconnect attaches to a large number of endpoint peripherals, address decoding could consume a large number of logic resources in the upstream interconnect and affect the system quality.*

In 2014.1 and later releases, address automation services in the Vivado IP integrator can optimize the amount of decoding logic required in cascaded AXI interconnect scenarios.

If the slave devices attached to the downstream interconnect are mapped contiguously, IP integrator configures the upstream AXI interconnect with an optimized address decoding range.

Consider the scenario in which a downstream interconnect has four attached AXI slaves, each with 4KB register ranges that are mapped contiguously into the system address map starting at address `0x40000000`. The address automation within the IP integrator configures the upstream interconnect with one address decoding range covering `0x40000000-0x40003fff`, as opposed to configuring the upstream interconnect with separate address decode ranges for each slave.

Note: This optimization requires the slave devices be mapped contiguously into an aggregate memory region with a size that is a power of 2.



RECOMMENDED: *When possible, use contiguous mappings of slave devices to benefit from the automatic address decode optimization available in IP integrator.*

Optimizing AXI on Zynq-7000 AP SoC Processors

See the *LogicCore IP Processing System 7: Product Guide for Vivado Design Suite* (PG082) [Ref 13] for more information.

When optimizing AXI for the Zynq®-7000 All Programmable SoC processor, the following optimization tips are recommended.

- The processing system 7 IP Block `IDWIDTH` is able to compress the `M_GP AXI IDWIDTH` using the static remap setting; potentially saving PL logic.
- For designs with multiple PL masters, consider using the multiple provided PS, PL, and AXI interfaces to reduce PL Logic utilization.
- PL masters accessing PS peripherals using non-secure accesses (`ARPROT[1] = 1` and/or `AWPROT[1] = 1`) generate a decode error by default.
- For higher throughput to the PS, PL masters should mark transactions as modifiable and bufferable `ARCACHE/AWCACHE[1:0] = b11`.

Considerations for High Performance AXI Interface Modules

This section summarizes the most important considerations when using the high performance AXI interface module from a software or user perspective.

- For general purpose AXI transfers, use the general purpose PS AXI ports and not these ports. These ports are optimized for high throughput applications, but have various limitations.
- The QoS PL inputs can be controlled from physical programmable logic signals or statically configured in APB registers. The signals allow QoS values to be changed on a per-command basis. The register control is static for all commands.
- The `AxCACHE[1]` must be set for upsizing to occur. If this bit is not set, expansion always occurs.
- If the PL design demands a continuous read data flow after the first data beat has been read, the design must first allow the read data FIFO to fill with the complete transaction data before popping the first data beat out. The FIFO level is exported to the PL for this purpose. This behavior might be useful if the PL master is not able to be throttled by `RVALID` after the first data exits the read FIFO.
- Wait states can be inserted if write commands are not asserted at least one cycle ahead of the corresponding first write data beat in 32-bit AXI channel slave interface mode.
- PL masters handle read data interleaving. If you do not want the PL masters to handle read data interleaving, then the PL masters must be set to not issue multi-threaded read commands to both the OCM and DDR from the same port by using the same `ARID` value for all outstanding read requests.
- The relationship of write FIFO occupancy to the write data ready to accept signal (`WREADY`) varies as follows:
 - In 64-bit AXI mode, FIFO not full (`SAXIHP0WCOUNT << 128`) always implies `WREADY=1`.
 - In 32-bit AXI mode, there is a dependency between the write address (`AWVALID`) and the write data (`WVALID`).
 - If the write address is presented at least one cycle before the first beat of any given write data burst, then the FIFO not full (`SAXIHP0WCOUNT << 128`) implies `WREADY=1`.

- If not, then `WREADY` is deasserted until the write address is produced. The reason for this back pressure is that in 32-bit mode, expansion/upsizing is performed on the data into the write data FIFO.
- Write response (`BVALID`) latency is dependent on many factors, such as DDR latency, DDR transaction reordering, and other conflicting traffic (including higher-priority transactions).
 - Write commands and data are sent the entire path to the slave (DDR or OCM) and the response is issued by the slave to return to the high performance AXI interface.
 - Transactions issued after reception of the write response are guaranteed to be committed later than the responded write transaction at the slave.

Note: By default, PS peripherals are set to secure TrustZone mode. This means that any non-secure accesses indicated with `AXPROT[1]=1` receive a `DECERR` response.
- The MMU and the MMU translation tables control the AXI behavior from the CPU to the PL. For example, to generate multiple outstanding AXI transactions on the PL, the `M_GP` address range cannot be set as strongly-ordered. Similar memory attributes control the generation of bursts to the PL through the `M_GP` interfaces.

[Memory Management Unit \(MMU\) in Chapter 3](#) provides a summary of MMU information. See the “Memory Management Unit” section in the *Zynq-7000 AP SoC Technical Reference Manual (UG585)* [Ref 32] for more information regarding optimizing PS performance.

AXI4-Stream IP Interoperability: Tips and Hints

Introduction

The AXI specification provides a framework that defines protocols for moving data between IP using a defined signaling standard. This standard ensures that IP can exchange data with each other and that data move across a system. The AXI protocol does not specify or enforce the interpretation of data; therefore, the data contents must be understood, and the different IP must have a compatible interpretation of the data.

This chapter provides information and presents concepts that help you construct systems by configuring your IP designs to be interoperable. Interoperability in the context of this document is defined as the ability to design two or more components in a system to exchange information and to use that information without extra design effort.

This chapter also describes areas where converters or additional effort are required to achieve IP interoperability.

Generally, components can achieve interoperability with other components using either or both of the following approaches:

- By adhering to published interface standards
- By making use of a “broker” of services (bridge) that can convert the interface of one component to the interface of another product.

Key Considerations

The key considerations for achieving IP Interoperability are:

- **Understand the IP Domain:** The interfaces used by the IP for exchanging information and the data type representation that is used for the transferred information can be classified by IP domain. Xilinx® IP generally follows a common set of guidelines to describe data contents and interface signaling within a given domain.

This chapter focuses on the following main domains:

- DSP/Wireless
- Video
- Communications
- AXI Infrastructure IP domains
- **Follow the Published Standard for the IP Domain:** [Chapter 4, AXI Feature Adoption in Xilinx Devices](#), provides an overview of the adoption of AXI4-Stream by Xilinx IP. This chapter further describes the various AXI4-Stream interface conventions and guidelines for IP configuration and use.
- **Validate the Data:** Understanding the IP domain and following the published standard lets you focus your effort on the key elements to achieve IP interoperability; however, it is imperative that you confirm that the IP operates as expected in the system using simulation or hardware testing.

The following figure illustrates how you need to approach the design and development process from IP selection to IP configuration for implementing systems with a high degree of IP interoperability.

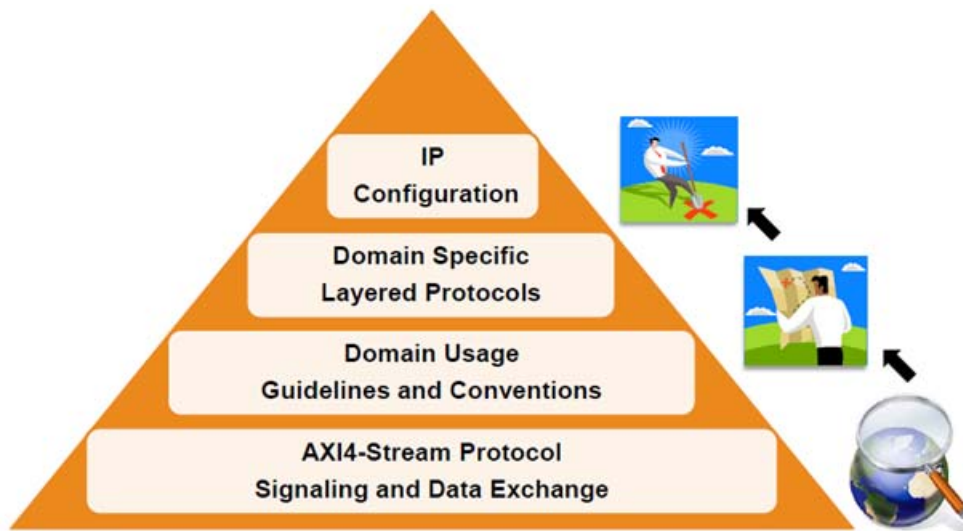

Figure 7-1: Process Tier for Understanding IP Interoperability

Begin the design process by understanding the AXI4-Stream protocol because it is the basis for data exchange. You can then move to higher levels of refinement by understanding the domain-level AXI4-Stream usage conventions, domain-level data organization and interpretation of data, and finally focus on the exact configuration settings and functions of each IP in the system. In this process, you narrow the solution space for each IP in the system.

AXI4-Stream Protocol

Review and use the AXI4-Stream signaling and data exchange interface protocol as described in [Chapter 4, AXI Feature Adoption in Xilinx Devices](#). AXI4-Stream is an interface-level protocol for IP to exchange raw data. Building on top of the signaling protocol, the various IP application domains can then establish common data types to enable IP to use exchanged data. AXI4-Stream defines optional signals with default tie-off rules and byte-aligned data widths with width conversion formulas. Some of the key IP interoperability considerations to focus on at the AXI4-Stream signaling levels are:

- Use of optional signals between two IP being connected to each other, as shown in the following figure.
- Data width of the connected interfaces.
- Burst length (such as the size of the data frame, block, or packet).
- Data representation (Layered Protocols).

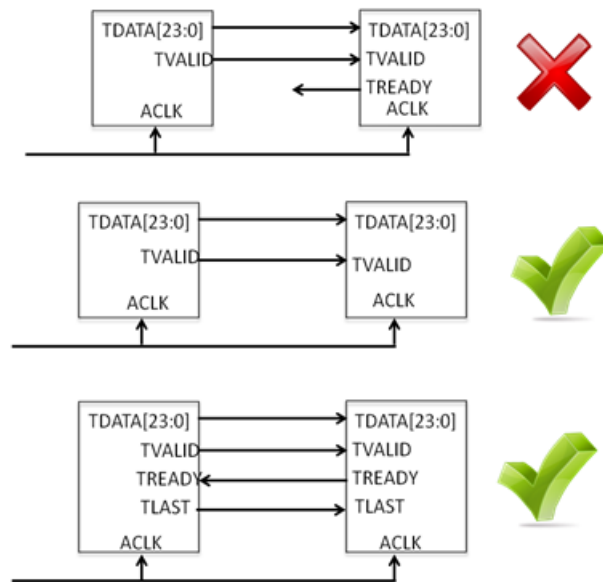

Figure 7-2: Establish AXI4-Stream Signaling-Level Data Exchange Compatibility

Domain Usage Guidelines and Conventions

Each IP application domain recommends common guidelines for usage of optional AXI4-Stream signals to facilitate IP interoperability. The four major IP application domains are shown in the following figure.

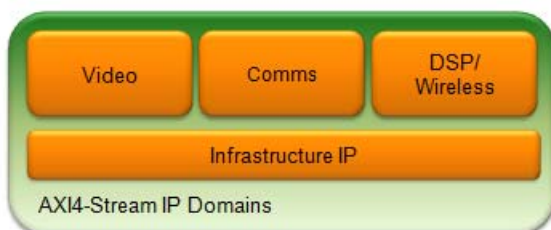

Figure 7-3: AXI4-Stream IP Domains

Video IP

AXI4-Stream IP in this domain carries framed video and image pixel data, and exchanges only pixel data and video line and frame markers. Other signals associated with physical interfaces such as: `hsync`, `vsync`, `active_video`, `blanking`, or other ancillary data signals; are not carried over AXI4-Stream.

AXI4-Stream video IP supports backpressure and elasticity in data flow around the `TVALID/TREADY` handshake.

Pixel data retains the relative location in the datastream; however, video pixel timing relative to `hsync` or `vsync` at a physical display is not preserved.

AXI4-Stream video IP uses layered protocols to encode a variety of video formats and resolutions. For more details on video IP adoption of AXI4-Stream, see [IP Using AXI4-Stream Video Protocol in Chapter 4](#).

The following table summarizes video IP domain AXI4-Stream signaling usage and guidelines.

Table 7-1: Video IP Domain AXI4-Stream Signaling Usage

Signal	Endpoint
ACLK	Used and Supported
ACLKEN	Limited Support
ARESTEN	Used and Supported
TVALID	Used and Supported
TREADY	Used and Supported
TDATA	Used and Supported

Table 7-1: Video IP Domain AXI4-Stream Signaling Usage (Cont'd)

Signal	Endpoint
TID	Not Supported
TDEST	Not Supported
TKEEP	Not Supported
TSTRB	Not Supported
TUSER	Used and Supported
TLAST	Used and Supported

DSP/Wireless IP

AXI4-Stream IP in the DSP and Wireless IP application domain operates on numerical streaming data paths. IP in this domain exchange data in either blocking (with backpressure) or non-blocking (continuous) modes.

You can organize data in either Time Division Multiplexing (TDM) or parallel paths, and use optional AXI4-Stream interfaces to perform configuration, control, and status reporting.

IP with multiple AXI4-Stream interfaces must account for IP core-specific synchronization rules between configuration and data channels (for example: a configuration packet must precede each data packet for block-based processing in some wireless IPs). See [DSP and Wireless IP: AXI Feature Adoption in Chapter 4](#).

The following table summarizes DSP and Wireless IP AXI4-Stream signaling usage and guidelines.

Table 7-2: DSP/Wireless IP Domain AXI4-Stream Signaling Usage

Signal	Endpoint
ACLK	Used and Supported
ACLKEN	Limited Support
ARESTEN	Used and Supported
TVALID	Used and Supported
TREADY	Used and Supported
TDATA	Used and Supported
TID	Not Supported
TDEST	Not Supported
TKEEP	Not Supported
TSTRB	Not Supported
TUSER	Used and Supported
TLAST	Used and Supported

Communications IP

AXI4-Stream IP in the communications application domain refers to *Endpoint* IP that implement high-speed communications protocols using transceivers or I/Os. Depending on the relationship with transceivers or I/Os that cannot accept backpressure, these AXI4-Stream interfaces can have limited handshaking options (for example no support for the TREADY signal with some IP that are closely tied to the physical interface).

AXI4-Stream communications IP are tightly coupled to the underlying protocol (such as PCIe, Ethernet, and SRIO) with explicit data formats and handshaking rules that limit IP interoperability across protocols.

AXI4-Stream communications IP are usually connected to custom logic in a user design, AXI infrastructure IP, or other protocol-specific IP (for example: Ethernet IP using AXI Ethernet DMA or PCIe bridging IP to other protocols).

More details on Communications IP are available at the Xilinx *IP Center website* [Ref 3].

The following table summarizes communications IP AXI4-Stream signaling usage and guidelines.

Table 7-3: Communications IP Domain AXI4-Stream Signaling Usage

Signal	Endpoint
ACLK	Used and Supported
ACLKEN	Not Supported
ARESTEN	Used and Supported
TVALID	Used and Supported
TREADY	Optionally Supported
TDATA	Used and Supported
TID	Not Supported
TDEST	Not Supported
TKEEP	Optionally Supported
TSTRB	Not Supported
TUSER	Optionally Supported
TLAST	Used and Supported

AXI Infrastructure IP

AXI4-Stream infrastructure IP refers to IP that generally exchanges or moves data within a system without using the contents of data or being tied to a specific data interpretation. Typically AXI4-Stream infrastructure IP are used as system building blocks or as test and debug IP. Common use models for infrastructure IP include width conversion, data switching and routing, buffering, pipelining, and DMA.

AXI infrastructure IP is required to support a wide range of optional and flexible signal interface configurations to meet the signaling needs of IP from all domains. This also helps to exchange data between mismatched AXI4-Stream master and slave signaling interfaces. More details are available on the *AXI4-Stream Interconnect IP website* [Ref 4].

For information about DMA IP that implement AXI4-Stream to AXI4 Memory-Mapped) data transfer, see [Chapter 3, Samples of Vivado AXI IP and Xilinx Processors](#).

The following table describes the main sub-categories of AXI4-Stream infrastructure IP and their useful characteristics. [Table 7-5](#) lists the infrastructure IP domain AXI4-Stream signaling usage.

Table 7-4: AXI4-Stream Infrastructure IP Sub-Categories

Type	Key Characteristics	Examples	Interoperability Considerations
Pass-through	<ul style="list-style-type: none"> Used for buffering, pipelining, or moving data. Does not change contents of data. 	<ul style="list-style-type: none"> Register Slice FIFO Clock Converter Crossbar Switch 	<ul style="list-style-type: none"> Does not change contents or organization of data. Generally compatible with all AXI4-Stream IP.
Modifier	<ul style="list-style-type: none"> Potential to change contents or organization of data. 	<ul style="list-style-type: none"> Width converter Bus Rip/Concatenation (Split/Combine) MUX/DeMUX Subset Converter Packer 	<ul style="list-style-type: none"> Performs specific algorithmic operations on data. Compatible with most AXI4-Stream IP with proper usage.
Stream Endpoint	<ul style="list-style-type: none"> Entry/Exit Point for a stream subsystem or processing pipeline. Usually the logical data source or terminus in a chain of IPs. 	<ul style="list-style-type: none"> DMA (general purpose) (MicroBlaze™ processor stream ports) AXI4-Lite to AXI4-Stream bridge Virtual FIFO Controller 	<ul style="list-style-type: none"> Usually the first or last IP in a processing pipeline Compatible with most AXI4-Stream IP with proper usage Might have limited support for TUSER, TID, and TDEST
Monitor	<ul style="list-style-type: none"> Attaches to an AXI interface for observation only. Does not alter the contents of data. 	<ul style="list-style-type: none"> AXI Debug Monitor AXI HW Protocol Checker Performance Monitor 	<ul style="list-style-type: none"> Observes but does not alter data. Taps an AXI4-Stream connection for viewing. Generally compatible with all AXI4-Stream IP.

Table 7-5: Infrastructure IP Domain AXI4-Stream Signaling Usage

Signal	Pass- Through	Modifier	Endpoint	Monitor
ACLK	Used and Supported	Used and Supported	Used and Supported	Used and Supported
ACLKEN	Used and Supported	Used and Supported	Not Supported	Not Supported
ARESTEN	Used and Supported	Used and Supported	Used and Supported	Used and Supported
TVALID	Used and Supported	Used and Supported	Used and Supported	Used and Supported
TREADY	Used and Supported	Used and Supported	Used and Supported	Used and Supported
TDATA	Used and Supported	Used and Supported	Used and Supported	Used and Supported
TID	Used and Supported	Used and Supported	Not Supported	Used and Supported
TDEST	Used and Supported	Used and Supported	Limited Support	Used and Supported
TKEEP	Used and Supported	Used and Supported	Limited Support	Used and Supported
TSTRB	Used and Supported	Used and Supported	Limited Support	Used and Supported
TUSER	Used and Supported	Used and Supported	Limited Support	Used and Supported
TLAST	Used and Supported	Used and Supported	Used and Supported	Used and Supported

Domain-Specific Data Interpretation and Interoperability Guidelines

Domain-specific protocols can be layered on top of the AXI4-Stream signaling layer so that IP can interpret and use the data that has been exchanged. This section summarizes key domain-specific layered protocol usage information and presents guidelines to help users focus on key concepts when constructing IP and systems to be inter-operable.

Video IP Layered Protocols

Video IP use layered protocols to represent the video format and resolution. Video IP must be configured to use the same video format and resolution to transfer information, such as industry recognized YUV/YUVA, RGB/RGBA video formats and 1920x1080P60 resolutions. Where necessary, format conversion IP such as color space converters can be used to convert the video between IP blocks in a system.

Video IP also has common conventions for packing the data bits for the color components (such as red, green, and blue components) into TDATA. AXI4-Stream signals such as TLAST and TUSER encode line and frame boundaries for a given video resolution.

Video IP also contain optional AXI4-Lite interface that can change the layered protocol during runtime, typically under microprocessor control.

See [Video IP: AXI Feature Adoption in Chapter 4](#) for details on the encoding of video layered protocols. The following table and [Table 7-7](#) summarize some of the key characteristics, interoperability considerations, and guidelines for layered protocols used in the Video IP domain.

Table 7-6: Video IP Layered Protocol Summary

Type	Key Characteristics	Examples	Interoperability Considerations
Video Format	<ul style="list-style-type: none"> Video IP support industry standard formats 	<ul style="list-style-type: none"> RGB YUV 4:2:2 	<ul style="list-style-type: none"> Use conversion IP video formats.
Pixels Encoding (Components)	<ul style="list-style-type: none"> Pixels (TDATA beats) consist of 1 to 4 components. Each component is 8, 10, 12, or 16 bits wide. Components are concatenated and 0-padded up to an overall byte width. 	<ul style="list-style-type: none"> 24-bit wide TDATA carrying RGB (3x8-bit components). 6-bit wide TDATA carrying YUV 4:2:2 (8-bit alternating V/U + 8-bit Y components). 	<ul style="list-style-type: none"> The relative placement order of the components in the TDATA beat is fixed. When the width of components mismatch, rules apply on how to scale the data.
Video Resolution / Framing	<ul style="list-style-type: none"> AXI4-Stream TLAST/ TUSER signaling is used to mark end-of-line and frame boundaries Only active video pixel data is transferred 	<ul style="list-style-type: none"> TUSER[0] marks the start of a frame TLAST marks end of line. Examples: <ul style="list-style-type: none"> 1024x768 would have 1024 TDATA beats per TLAST. 768 TLAST beats per TUSER[0]. 	<ul style="list-style-type: none"> TLAST and TUSER must be preserved and placed at correct intervals relative to pixels. Some video IP are capable of recovering from corrupted or incomplete frame data and re-locking to the framing signals. Connected Video IP must have the same frame resolution or rescaling IP. is required.

Table 7-7: Video IP Interoperability, Considerations, and Guidelines

Guideline	Description	Rule to Achieve Interoperability	User Effort/Notes
Data Type	1-4 components per pixel, 8,10,12,16 bit per component	Converter cores provided. All cores configurable to support 8,10,12,16 bit data.	Seamless if video format and resolution match; Standard adapters provided to change formats and resolution.
Data Burst	Video standards with up to 8k pixels per line (burst) supported	All cores configurable to support standard burst sizes.	Ensure that connected IP use the same settings.
AXI4-Stream Optional Signals	Optional: <code>ACLKEN</code> , <code>ARESETN</code> , Else Fixed set (<code>TUSER[0]</code> , <code>TLAST</code> , <code>TREADY</code> , <code>TVALID</code> , <code>TDATA</code>)	AXI-FIFO needed to bridge between different <code>ACLK</code> or <code>ACLKEN</code> domains.	Standard adapter might be needed (AXI4-Stream FIFO or AXI4-Stream Interconnect)
AXI4-Stream TUSER Signals	Only the <code>TUSER 0</code> signal used consistently across all video cores	<code>TUSER0</code> is required and is used to signal frame boundaries.	Special considerations might be needed for IP that can generate or recover from partial frames (for example, handling when cable is removed and reconnected)
Number of Channels and AXI4-Lite Dependency	Generally single AXI4-Stream through IP, but some cores have multiple inputs/output streams; Most IP have an optional AXI4-Lite control interface.	For cores with multiple input/output streams or when AXI4-Lite is used, read the datasheet to understand data relationships.	Core can permit format/resolution to be changed using AXI4-Lite requiring care to coordinate any runtime changes across system.

DSP/Wireless IP Layered Protocols

DSP/Wireless IP use layered protocols to represent numerical information and structures to perform processing such as filtering, arithmetic operations. DSP/ Wireless IP usually have a flow through architecture with input and output stream interfaces to take in data, perform operation on the data, and send out the data.

Data flow is usually optional between blocking (with backpressure using `TREADY`) and non-blocking (continuous data flow without `TREADY`).

DSP/Wireless IP also support data organized into TDM or parallel paths to operate on numeric data structures such as arrays. The streams can also carry optional sideband status signals to supplement the numeric data with core-specific information. DSP/Wireless IP also often contain control AXI4-Stream interfaces for optional runtime control and status such as the ability to change filter coefficients at runtime using a secondary AXI4-Stream interface.

See [DSP and Wireless IP: AXI Feature Adoption](#) for details of encoding DSP/Wireless layered protocols. The following table and [Table 7-9](#) summarizes some of the key characteristics, interoperability considerations, and guidelines for layered protocols used in the DSP/Wireless IP domain.

Table 7-8: DSP/Wireless IP Layered Protocol Summary

Key Characteristi	Description	Examples	Interoperability Considerations
Number of Data Transfers per Invocation	<ul style="list-style-type: none"> Sample-Based Processing: IP data processing is applied independently to every single AXI4-Stream transfer. Block-Based Processing: IP data processing is applied to a "block" "packet" of AXI4-Stream transfers. 	<ul style="list-style-type: none"> Sample: complex multiplier operates on a data sample at a time. Block: FFT of a given point size. 	Block based IP must have same notion of block size to inter-operate.
Number of Data Transfers per Invocation	<ul style="list-style-type: none"> Single-Channel: 1 logical stream of data. Multi-Channel: data being processed in parallel (could be a single AXI4-Stream interface with parallel data concatenated together on TDATA). 	<ul style="list-style-type: none"> FIR compiler can be configured to operate single or multiple parallel data lanes. Multi-channel mode allows DSP resources to be shared across multiple data paths. 	Data must be concatenated together or split out to change number of parallel data streams.
Data type representati on of TDATA	<ul style="list-style-type: none"> Unit: single datum Array: multiple data Structure: tuples or special data structures for control/status interfaces 	<ul style="list-style-type: none"> FIR compiler can operate on unit data or array of data when configured for single or multiple data paths, respectively. Control/status AXI4-Stream interfaces usually require structured data such as FFT configuration 	<ul style="list-style-type: none"> IP must have same notion of data type representation to interoperate. Structured TDATA is often used in control/status interfaces and need custom logic or programmable IP (like a microprocessor) to generate.

Table 7-8: DSP/Wireless IP Layered Protocol Summary (Cont'd)

Key Characteristi	Description	Examples	Interoperability Considerations
Use of TUSER signal for sideband data	None: No TUSER signal used Pass-through: TUSER signal is passed from an input interface to an output interface IP Specific: TUSER conveys IP-specific sideband data.	<ul style="list-style-type: none"> Complex Multiplier can work without TUSER or can Pass-through TUSER. DDS compiler can include TUSER in its output interface with IP-specific TDM channel markers. 	<ul style="list-style-type: none"> IP-specific TUSER often requires custom logic to decode. TUSER Pass-through mode is useful for transmitting user information through a core to match latency with the data.
Use of TLAST signal	None: No TLAST signal used. Pass-thru: TLAST signal is passed from an input interface to an output interface. Block end marker: TLAST indicates the last transfer in a block. IP-specific TLAST used to mark an IP specific location in the data transfers	<ul style="list-style-type: none"> Divider Generator can work without TLAST or can Pass-through TLAST. FFT uses TLAST for block end marker 	<ul style="list-style-type: none"> IP must have same notion of TLAST when used as block end marker. TLAST Pass-through mode is useful for transmitting user information through a core with latency matched to that of the data. IP specific TLAST often requires custom logic to decode TLAST.

Table 7-9: DSP/Wireless Interoperability Guidelines

Guideline	Description	Rule to Achieve Interoperability	User Effort/Notes
Data Type	Scalars, arrays, and structures with data type elements for fixed and floating point number representation.	Adhere to defined data types and conventions. For example real versus integer, common binary point and data size.	Must understand data types/structures and ensure consistency; adapters might be needed
Data Burst	Sample or block processing; IP processing applied to a single transfer or a block of transfers	Use of (optional) TLAST to delimit blocks, packets, or frames.	Must align block sizes to match data structure size, adapters might be needed.
AXI4-Stream Optional Signals	Optional: ACLKEN, TREADY, TLAST, TUSER. Fixed: TDATA, TVALID	Adhere to DSP/Wireless IP specific guidelines in DSP and Wireless IP: AXI Feature Adoption in Chapter 4 .	Optional signals must be used consistently or adapters are needed.
AXI4-Stream TUSER Signals	No use, Pass-through, or IP specific use of TUSER. TUSER is generally optional.	For higher interoperability, avoid use of IP specific TUSER.	TUSER signals must be used consistently. Custom logic might be needed to handle IP-specific TUSER.
Data Type	Scalars, arrays, and structures with data type elements for fixed and floating point number representation.	Adhere to defined data types and conventions. For example real versus integer, common binary point and data size.	Must understand data types/structures and ensure consistency; adapters might be needed

Communications IP Layered Protocols

IP in this domain use layered protocols to represent communications protocols, typically networking packets. Packets can be fixed or variable sized depending on the protocol (such as Ethernet and PCIe). IP are usually closely tied to the physical layer interface or logical level interface with transmit and receive AXI4-Stream interfaces, sideband `TUSER` signals for control/status, and some offer additional AXI4-Lite and AXI4 memory-mapped interfaces.

Because of the specific relationship to a communications protocol standard, IP in this domain are often used with custom logic, infrastructure IP, other IP of the same protocol type.

The following table summarizes some of the key guidelines for layered protocols used in the Communications IP domain.

Table 7-10: Communications IP Layered Protocol Interoperability Guidelines

Guideline	Description	Rule to Achieve	User Effort/Notes
Data Type	Packetized data, with and without headers/footers. Matched to protocols like Ethernet, PCIe, or SRIO.	Remove header and footer to access raw packet data or transfer data to memory-mapped space (for example) using a DMA engine.	Must understand data types and ensure packet data is delivered in the correct order. Adapters might be needed.
Data Burst	Variable size: Minimum can be a single cycle of data. Maximum depends upon the parent protocol	All cores configurable to support standard burst sizes, up to a defined limit for a given protocol	Care must be taken to ensure that legal-sized packets are transferred between cores. Adapters might be needed to break apart too-large packets.
AXI4-Stream Optional Signals	<code>TREADY</code> , <code>TKEEP</code> , <code>TDATA</code> , <code>TUSER</code> , <code>TLAST</code> . In some cases, <code>ACLKEN</code> , <code>TDEST</code> , <code>TID</code> .	Use adapters for infrastructure IP. <code>TDEST/TID</code> can be used for data interleaving.	Adapters might be required.
AXI4-Stream <code>TUSER</code> Signals	Variety of uses and sizes. Common uses: packet discontinue, framing signals, packet details	Avoid using <code>TUSER</code> . Set control/status information in AXI4-Lite register space if possible	Migrate <code>TUSER</code> signals to dedicated AXI4-Lite or AXI4-Stream sideband bus. Adapter might be required.
Number of Channels and AXI4-Lite Dependency	Generally single AXI4-Stream in each direction, through IP. SRIO can have up to 8 streams in each direction.	For cores with multiple input/output streams, read the datasheet to understand data relationships.	Cores must have an appropriate port to which to connect. Refer to the individual datasheet for each core.

AXI Infrastructure IP Layered Protocols

IP in this domain often do not use specific layered protocols but are configurable to Pass-through data or to generate/receive data using a processor or DMA engine.

The key elements for interoperability is to use the AXI4-Stream protocol following the recommendations in [Signaling Protocol in Chapter 3](#).

AXI Infrastructure IP is designed to be broadly compatible with IP from different domains because it has highly configurable interfaces, and generally does not use the contents of the data. The following table summarizes some of the key characteristics and interoperability considerations for the AXI Infrastructure IP domain.

Table 7-11: AXI Infrastructure IP Interoperability Guidelines

Guideline	Description	Rule to Achieve	User Effort/Notes
AXI4-Stream Optional Signals Use	<ul style="list-style-type: none"> Endpoint type IP generally limit support for TID, TDEST (unless multi-channel IP), TSTRB, TUSER. Endpoint IP using TLAST should be aware of burst size. TKEEP only for packet remainders. 	<ul style="list-style-type: none"> Use “Continuous” or “Continuous Aligned Streams”. 	<ul style="list-style-type: none"> Low for Pass-through and Monitor IP types. Generally low when using core signals TDATA, TVALID, TREADY, TLAST, TKEEP (remainders). Medium to high with more complex systems using TID, TDEST, TSTRB, or TUSER.
Layered Protocols	<ul style="list-style-type: none"> Pass-through and Monitor IP types do not alter data. Modifiers can transform data. Endpoints can synthesize or receive layered protocols with proper configuration. 	<ul style="list-style-type: none"> Minimize use of TID, TDEST, TSTRB, and TUSER. Consider how modifiers change the data structures used by layered protocols. Endpoints require the user to properly program them to generate data contents matching the layered protocol. 	<ul style="list-style-type: none"> Low for Pass-through and Monitor IP types. Medium when using modifiers that can alter the data encodings algorithmically. Medium to High for endpoint IPs that must be configured and programmed properly to match the requirements of layered protocols.
Other Interoperability Factors	<ul style="list-style-type: none"> There are Interdependencies, such as Endpoint IP often have additional AXI4-Lite control interfaces. 	<p>Pay attention to real time system impact when using infrastructure IP, such as FIFOs might increase latency.</p>	<ul style="list-style-type: none"> Low for Monitor types. Low to Medium for Pass-through and Modifier types that could affect real time behavior. Medium to high for endpoint types which could have control ports.
Interfacing to IP in other Domains	<ul style="list-style-type: none"> Pass-through and Monitor types designed to work with all domains. Modifier IP can work in video or DSP domains, but need users to validate data structure integrity. Endpoint IP have limited ability to interface to other domains and might need domain specific endpoint IP (example AXI Video DMA, PCIe DMA, and so forth). 	<ul style="list-style-type: none"> Care must be taken to configure and program Endpoints to match the layered protocol requirements of other IP domains. 	<ul style="list-style-type: none"> Low for Pass-through and Monitor IP types. Medium when using modifiers that can alter data structures. <p>Medium to High for using endpoints that have to synthesize or receive layered protocols.</p>

AXI Adoption Summary

Introduction

This appendix provides a summary of protocol signals adopted by Xilinx® in the AXI4 and AXI-Lite, and AXI4-Stream interface protocol IP. Consult the AXI specifications (available at www.amba.com) for complete descriptions of each of these signals.

Global Signals

TableA-1: Global AXI Signals

Signal	AXI4	AXI4-Lite
ACLK	Clock source.	
ARESETN	<p>Global reset source, active-Low. This signal is not present on the interface when a reset source (of either polarity) is taken from another signal available to the IP. Xilinx IP generally must deassert <code>TVALID</code> and <code>TREADY</code> outputs within 8 cycles of reset assertion, and generally require a reset pulse-width of 16 or more clock cycles of the slowest clock.</p> <p>Some Xilinx IP might document that they can accept <code>ARESETN</code> asserted for fewer than 16 cycles. For example, DSP IP require <code>ARESETN</code> asserted for a minimum of 2 cycles on the AXI4-Stream interfaces.</p>	

AXI4 and AXI4-Lite Signals

AXI4 and AXI4-Lite Write Address Channel Signals

Note: A read-only master or slave interface omits the entire write address channel.

Table A-2: Write Address Channel Signals

Signal	AXI4	AXI4-Lite
AWID	Fully supported. Masters need only output the set of ID bits that it varies (if any) to indicate re-orderable transaction threads. Single-threaded master interfaces can omit this signal. Masters do not need to output the constant portion that comprises the Master ID, as this is appended by the AXI Interconnect.	Signal not present.
AWADDR	Fully supported. Widths up to 64 bits. High-order bits outside the native address range of a slave are ignored (trimmed), by an endpoint slave, which could result in address aliasing within the slave.	
AWLEN	Fully supported. Support bursts: <ul style="list-style-type: none"> • Up to 256 beats for incrementing (INCR). • 16 beats for WRAP. 	Signal not present.
AWSIZE	Transfer width 8 to 1024 bits supported. Use of narrow bursts where <code>AWSIZE</code> is less than the native data width is not recommended.	Signal not present.
AWBURST	INCR and WRAP fully supported. FIXED bursts are not recommended. Conversions of FIXED bursts through AXI Interconnect infrastructure may have sub-optimal performance.	Signal not present
AWLOCK	Exclusive access support not implemented in endpoint Xilinx IP. Infrastructure IP will pass exclusive access bit across a system.	Signal not present.
AWCACH	0011 value recommended. Xilinx IP generally ignores (as slaves) or generates (as masters) transactions as Normal, Non-cacheable, Modifiable, and Bufferable. Infrastructure IP will pass Cache bits across a system.	Signal not present
AWPROT	000 value recommended. Xilinx IP generally ignores (as slaves) or generates transactions (as masters) with Normal, Secure, and Data attributes. Infrastructure IP passes Protection bits across a system.	
AWQOS	Not implemented in Xilinx Endpoint IP. Infrastructure IP passes QoS bit across a system.	Signal not present

Table A-2: Write Address Channel Signals (Cont'd)

Signal	AXI4	AXI4-Lite
AWREGION	Can be implemented in Xilinx Endpoint slave IP. Not present on master IP. Generated by AXI Interconnect using corresponding address decoder range settings.	Signal not present
AWUSER	Generally, not implemented in Xilinx endpoint IP. Infrastructure IP passes USER bits across a system.	Signal not present.
AWVALID	Fully supported.	
AWREADY	Fully supported.	

AXI4 and AXI4-Lite Write Data Channel Signals

Note: A read-only master or slave interface omits the entire Write Data Channel.

TableA-3: Write Data Channel Signals

Signal	AXI4	AXI4-Lite
WDATA	Native width 32 to 1024 bits supported.	32-bit width supported. 64-bit AXI4-Lite native data width is not currently supported
WSTRB	Fully supported.	Slaves interface can elect to ignore <code>WSTRB</code> (assume all bytes valid).
WLAST	Fully supported.	Signal not present.
WUSER	Generally, not implemented in Xilinx endpoint IP. Infrastructure IP will pass USER bits across a system.	Signal not present.
WVALID	Fully supported.	
WREADY	Fully supported.	

AXI4 and AXI4-Lite Write Response Channel Signals

The following table lists the Write Response Channel signals.

Note: A read-only master or slave interface omits the entire write response channel.

Table A-4: Write Response Channel Signals

Signal	AXI4	AXI4-Lite
BID	Fully supported. See <code>AWID</code> for more information.	Signal not present.
BRESP	Fully supported.	<code>EXOKAY</code> value not supported by specification.
BUSER	Generally, not implemented in Xilinx endpoint IP. Infrastructure IP will pass USER bits across a system.	Signal not present.

Table A-4: Write Response Channel Signals (Cont'd)

Signal	AXI4	AXI4-Lite
BVALID	Fully supported.	
BREADY	Fully supported.	

AXI4 and AXI4-Lite Read Address Channel Signals

Note: A write-only master or slave interface omits the entire read address channel.

Table A-5: Write Address Channel Signals

Signal	AXI4	AXI4-Lite
ARID	Fully supported. Masters need only output the set of ID bits that it varies (if any) to indicate re-orderable transaction threads. Single-threaded master interfaces can omit this signal. Masters do not need to output the constant portion that comprises the "Master ID", as this is appended by the AXI Interconnect.	Signal not present.
ARADDR	Fully supported. Widths up to 64 bits. High-order bits outside the native address range of a slave are ignored (trimmed) by an endpoint slave, which could result in address aliasing within the slave.	
ARLEN	Fully supported. Support bursts: <ul style="list-style-type: none"> Up to 256 beats for incrementing (INCR). 16 beats for WRAP. 	Signal not present
ARSIZE	Transfer width 8 to 1024 bits supported. Use of narrow bursts where ARSIZE is less than the native data width is not recommended.	Signal not present.
ARBURST	INCR and WRAP fully supported. FIXED bursts are not recommended. Conversions of FIXED bursts through AXI Interconnect infrastructure may have sub-optimal performance.	Signal not present.
ARLOCK	Exclusive access support not implemented in Endpoint Xilinx IP. Infrastructure IP passes exclusive access bit across a system.	Signal not present.
ARCACHE	0011 value recommended. Xilinx IP generally ignores (as slaves) or generates (as masters) transactions with Normal, Non-cacheable, Modifiable, and Bufferable. Infrastructure IP will pass Cache bits across a system.	Signal not present.
ARPROT	Xilinx IP generally ignore (as slaves) or generate transactions (as masters) with Normal, Secure, and Data attributes. Infrastructure IP passes Protection bits across a system. 000 value recommended.	
ARQOS	Not implemented in Xilinx Endpoint IP. Infrastructure IP passes QoS bit across a system	Signal not present.

Table A-5: Write Address Channel Signals (Cont'd)

Signal	AXI4	AXI4-Lite
ARREGION	Can be implemented in Xilinx Endpoint Slave IP. Not present on master IP. Generated by AXI Interconnect using corresponding address decoder range settings.	Signal not present.
ARUSER	Generally, not implemented in Xilinx Endpoint IP. Infrastructure IP passes User bits across a system.	Signal not present.
ARVALID	Fully supported.	
ARREADY	Fully supported.	

AXI4 and AXI4-Lite Read Data Channel Signals

The following table lists the Read Data Channel signals.

Note: A read-only Master or slave interface omits the entire read data channel.

Table A-6: Read Data Channel Signals

Signal	AXI4	AXI4-Lite
RID	Fully supported. See ARID for more information.	Signal not present.
RDATA	Native width 32 to 1024 bits supported.	32-bit width supported. 64-bit AXI4-Lite native data width is not supported.
RRESP	Fully supported.	EXOKAY value not supported by specification.
RLAST	Fully supported.	Signal not present.
RUSER	Generally, not implemented in Xilinx Endpoint IP. Infrastructure IP will pass User bits across a system.	Signal not present.
RVALID	Fully supported.	
RREADY	Fully supported.	

AXI4-Stream Signal Summary

The following table lists the AXI4-Stream signal summary.

TableA-7: AXI4-Stream Signal Summary

Signal	Optional	Default (All Bits)	Description
TVALID	No	N/A	No change.
TREADY	Yes	1	No change
TDATA	Yes	0	No change. Xilinx AXI IP convention: 8 through 4096 bit widths are used by Xilinx AXI IP (establishes a testing limit).
TSTRB	Yes	Same as TKEEP else 1	No change. Generally, the usage of TSTRB is to encode Sparse Streams. TSTRB should not be used only to encode packet remainders.
TKEEP	Yes	1	In Xilinx IP, there is only a limited use of Null Bytes to encode the remainders bytes at the end of packetized streams. TKEEP is not used in Xilinx endpoint IP for signaling leading or intermediate null bytes in the middle of a stream.
TLAST	Yes	0	Indicates the last data beat of a packet. Omission of TLAST implies a continuous, non-packetized stream.
TID	Yes	0	No change. Xilinx AXI IP convention: Only 1-32 bit widths are used by Xilinx AXI IP (establishes a testing limit).
TDEST	Yes	0	No change Xilinx AXI IP convention: Only 1-32 bit widths are used by Xilinx AXI IP (establishes a testing limit).
TUSER	Yes	0	No change Xilinx AXI IP convention: Only 1-4096 bit widths are used by Xilinx AXI IP (establishes a testing limit).

AXI Terminology

Terminology

The following table lists the AXI terminology.

Table B-1: AXI Terminology

Term	Type	Description	Usage
AXI	Generic	The generic term for all implemented AXI protocol interfaces.	General description.
AXI4	Memory-mapped block transfers	Addressed interface bursts up to 256 data beats.	Embedded and memory cores. Examples: MIG, block Ram, PCIe Bridge, FIFO.
AXI4-Lite	Control Register Subset	32-bit data, memory-mapped, lightweight, single data beat transfers only.	Management registers. Examples: Interrupt Controller, UART Lite, IIC Bus Interface.
AXI4-Stream	Streaming Data Subset	Unidirectional links modeled after a single write channel. Unlimited burst length.	Used in DSP, Video, and communication applications.
Interface	AXI4 AXI4-Lite AXI4-Stream	Collection of one or more channels that expose an IP core function, connecting a master to a slave. Each IP can have multiple interfaces.	All.
Channel	AXI4 AXI4-Lite AXI4-Stream	Independent collection of AXI signals associated with a VALID signal.	All.
Bus	Generic	Multiple-bit signal (Not an interface or a channel).	All.

Table B-1: AXI Terminology (Cont'd)

Term	Type	Description	Usage
Transaction	AXI4-Stream	Complete communication operation across a channel , composed of one or more transfers . A complete action.	Used in DSP, Video, and communication applications.
	AXI4 AXI4-Lite	Complete collection of related read or write communication operations across address, data, and response channels, composed of one or more transfers . A complete read or write request.	Embedded and memory cores. Management registers.
Transfer	AXI4 AXI4-Lite AXI4-Stream	Single clock cycle where information is communicated, qualified by a VALID hand-shake. Data beat	All
Burst	AXI4 AXI4-Lite AXI4-Stream	Transaction that consists of more than one transfer .	All
master	AXI4 AXI4-Lite AXI4-Stream	An IP or device (or one of multiple interfaces on an IP) that generates AXI transactions out from the IP onto the wires connecting to a slave IP.	All
slave	AXI4 AXI4-Lite AXI4-Stream	An IP or device (or one of multiple interfaces on an IP) that receives and responds to AXI transactions coming in to the IP from the wires connecting to a master IP.	All
master interface (generic)	AXI4 AXI4-Lite AXI4-Stream	An interface of an IP or module that generates out-bound AXI transactions and thus is the initiator (source) of an AXI transfer.	All
slave interface (generic)	AXI4 AXI4-Lite AXI4-Stream	An interface of an IP or module that receives in-bound AXI transactions and becomes the target (destination) of an AXI transfer.	All
SI	AXI4 AXI4-Lite	AXI Interconnect Slave Interface: <ul style="list-style-type: none"> For the IP integrator embedded flow, Vectored AXI slave interface receiving in-bound AXI transactions from all connected master devices. For the Vivado IP flow, one of multiple slave interfaces connecting to one master device. 	IP integrator

Table B-1: AXI Terminology (Cont'd)

Term	Type	Description	Usage
MI	AXI4 AXI4-Lite	AXI Interconnect Master Interface: <ul style="list-style-type: none"> For the IP integrator embedded flow, Vectored AXI master interface generating out-bound AXI transactions to all connected slave devices. For the Vivado IP flow, one master interface connecting to one slave device. 	IP integrator
SI slot	AXI4 AXI4-Lite	Slave Interface Slot: A slice of the slave Interface vector signals of the Interconnect that connect to a single master IP.	IP integrator
MI slot	AXI4 AXI4-Lite	Master Interface Slot: A slice of the Master Interface vector signals of the Interconnect that connect to a single Master Interface slave IP.	IP integrator
SI-side	AXI4 AXI4-Lite	Refers to a module interface closer to the SI side of the Interconnect.	All
MI-side	AXI4 AXI4-Lite	Refers to a module interface closer to the MI side of the Interconnect.	All
upsizer	AXI4 AXI4-Lite AXI4-Stream	Data width conversion function in which the data path width gets wider when moving in the direction from the slave interface toward the master interface (regardless of write or read direction).	All
downsizer	AXI4 AXI4-Lite AXI4-Stream	Data width conversion function in which the data path width gets narrower when moving in the direction from the slave interface toward the master interface (regardless of write or read direction).	All
SAMD	Topology	Shared-Address, Multiple-Data: Configuration of AXI Interconnect where data transfers can occur independently and concurrently between different master and slave devices.	All
SASD	Topology	Shared-Address, Shared-Data: Configuration of AXI Interconnect where a single read and write pathway is implemented.	All
Shared-Access	Topology	Configuration of AXI Interconnect based on SASD topology where only one transaction is issued at a time to minimize resources.	EDK, Embedded

Table B-1: AXI Terminology (Cont'd)

Term	Type	Description	Usage
Crossbar	Topology	Configuration of AXI Interconnect based on SAMD topology where data pathways are implemented according to sparse connectivity between master and slave devices.	All
Crossbar	Structural	Module at the center of the AXI Interconnect that routes address, data and response channel transfers between various SI slots and MI slots.	All

Additional Resources and Legal Notices

Xilinx Resources

For support resources such as Answers, Documentation, Downloads, and Forums, see [Xilinx Support Page](#).

Solution Centers

See the Xilinx [Solution Centers](#) for support on devices, software tools, and intellectual property at all stages of the design cycle. Topics include design assistance, advisories, and troubleshooting tips.

Documentation Navigator and Design Hubs

Xilinx Documentation Navigator provides access to Xilinx documents, videos, and support resources, which you can filter and search to find information. To open the Xilinx Documentation Navigator (DocNav):

- From the Vivado IDE, select **Help > Documentation and Tutorials**.
- On Windows, select **Start > All Programs > Xilinx Design Tools > DocNav**.
- At the Linux command prompt, enter `docnav`.

Xilinx Design Hubs provide links to documentation organized by design tasks and other topics, which you can use to learn key concepts and address frequently asked questions. To access the Design Hubs:

- In the Xilinx Documentation Navigator, click the **Design Hubs View** tab.
- On the Xilinx website, see the [Design Hubs](#) page.

Note: For more information on Documentation Navigator, see the [Documentation Navigator](#) page on the Xilinx website.

Third-Party Documentation

Additional reference documentation:

1. Instructions on how to download the ARM® AMBA® AXI specifications are at <http://www.amba.com>. See the:
 - *AMBA AXI and ACE Protocol Specification (AXI3, AXI4, and AXI4-Lite Sections)*
 - *AMBA4 AXI4-Stream Protocol Specification*
 2. [Cadence AXI UVC](#)
-

Xilinx Documentation

3. [Xilinx IP Center](#)
4. [AXI4-Stream Interconnect](#) page
5. *Zynq-7000 All Programmable SoC Verification IP Data Sheet (DS940)*
6. *LogiCORE IP AXI DMA Product Guide (PG021)*
7. *LogiCORE IP AXI DataMover Product Guide (PG022)*
8. *LogiCORE IP AXI Central Direct Memory Access Product Guide (PG034)*
9. *AXI-4 Stream Interconnect IP Product Guide for Vivado Design Suite (PG035)*
10. *LogiCORE IP AXI Performance Monitor Product Guide (PG037)*
11. *LogiCORE IP AXI Virtual FIFO Controller Product Guide (PG038)*
12. *LogiCORE IP AXI Interconnect IP Product Guide (PG059)*
13. *LogicCore IP Processing System 7: Product Guide for Vivado Design Suite (PG082)*
14. *AXI4-Stream Infrastructure IP Suite: Product Guide for Vivado Design Suite (PG085)*
15. *LogiCORE IP AXI Protocol Checker: Product Guide for Vivado Design Suite (PG101)*
16. *MicroBlaze Debug Module (MDM) Product Guide (PG115)*
17. *LogiCORE IP IBERT for 7 Series GTX Transceivers (PG132)*
18. *LogiCORE IP IBERT for 7 Series GTP Transceivers (PG133)*
19. *LogiCORE IP AXI4-Stream Protocol Checker: Product Guide for Vivado Design Suite (PG145)*
20. *LogiCORE IP IBERT for 7 Series GTH Transceivers (PG152)*
21. *LogiCORE IP Virtual Input/Output Product Guide (PG159)*

22. *LogiCORE IP Integrated Logic Analyzer Product Guide* ([PG172](#))
23. *LogiCORE IP AXI SmartConnect Product Guide* ([PG247](#))
24. *LogiCORE IP Product Guide: AXI Verification* ([PG267](#))
25. *LogiCORE IP Product Guide: AXI4-Stream Verification IP* ([PG277](#))
26. *Zynq-7000 All Programmable SoC Technical Reference Manual* ([UG585](#))
27. *AXI-4 Stream Video IP and System Design Guide* ([UG934](#))
28. *Vivado Design Suite Tutorial: Programming and Debugging* ([UG936](#))
29. *Vivado Design Suite User Guide: Release Notes, Installation, and Licensing* ([UG973](#))
30. *Vivado Design Suite User Guide: Designing with IP* ([UG896](#))
31. *Vivado Design Suite User Guide: Model-Based DSP Design Using System Generator* ([UG897](#))
32. *Vivado Design Suite User Guide: Logic Simulation* ([UG900](#))
33. *Vivado Design Suite User Guide: High-Level Synthesis* ([UG902](#))
34. *Vivado Design Suite User Guide: Programming and Debugging* ([UG908](#))
35. *ISE to Vivado Design Suite Migration Guide* ([UG911](#))
36. *Vivado Design Suite Tutorial: Programming and Debugging* ([UG936](#))
37. *MicroBlaze Processor Reference Guide* ([UG984](#))
38. *Vivado Design Suite User Guide: Designing IP Subsystems Using IP Integrator* ([UG994](#))
39. *Vivado Design Suite Tutorial: Designing IP Subsystems Using IP Integrator* ([UG995](#))
40. *Zynq UltraScale+ MPSoC Technical Reference Manual* ([UG1085](#))
41. *Vivado Design Suite User Guide: Creating and Packaging Custom IP* ([UG1118](#))

Xilinx White Papers and Application Notes

42. *White Paper: Maximize System Performance Using Xilinx Based AXI4 Interconnects* ([WP417](#))
43. *AXI Multi-Ported Memory Controller Application Note* ([XAPP739](#))
44. *Designing High-Performance Video Systems with the AXI Interconnect* ([XAPP740](#))
45. *7 Series FPGAs AXI Multi-Port Memory Controller Using the Vivado IP Integrator Tool* ([XAPP1164](#))
46. *Methods for Integrating AXI4-based IP Using Vivado IP Integrator* ([XAPP1204](#))
47. *Partial Reconfiguration of a Hardware Accelerator with Vivado Design Suite* ([XAPP1231](#))
48. [Vivado Design Suite Documentation](#)

General Xilinx References

49. [Xilinx System Generator for DSP Page](#)

Vivado Design Suite Video Tutorials

50. [Vivado Design Suite QuickTake Video: Targeting Zynq Devices Using Vivado IP Integrator](#)
51. [Vivado Design Suite QuickTake Video: Designing with Vivado IP Integrator](#)
52. [Vivado Design Suite QuickTake Video: Targeting Zynq Devices Using Vivado IP Integrator](#)
53. [Vivado Design Suite QuickTake Video: How to Use the Zynq-7000 Verification IP to Verify and Debug using Simulation](#)
54. [Vivado Design Suite QuickTake Video Tutorials](#)

Please Read: Important Legal Notices

The information disclosed to you hereunder (the "Materials") is provided solely for the selection and use of Xilinx products. To the maximum extent permitted by applicable law: (1) Materials are made available "AS IS" and with all faults, Xilinx hereby DISCLAIMS ALL WARRANTIES AND CONDITIONS, EXPRESS, IMPLIED, OR STATUTORY, INCLUDING BUT NOT LIMITED TO WARRANTIES OF MERCHANTABILITY, NON-INFRINGEMENT, OR FITNESS FOR ANY PARTICULAR PURPOSE; and (2) Xilinx shall not be liable (whether in contract or tort, including negligence, or under any other theory of liability) for any loss or damage of any kind or nature related to, arising under, or in connection with, the Materials (including your use of the Materials), including for any direct, indirect, special, incidental, or consequential loss or damage (including loss of data, profits, goodwill, or any type of loss or damage suffered as a result of any action brought by a third party) even if such damage or loss was reasonably foreseeable or Xilinx had been advised of the possibility of the same. Xilinx assumes no obligation to correct any errors contained in the Materials or to notify you of updates to the Materials or to product specifications. You may not reproduce, modify, distribute, or publicly display the Materials without prior written consent. Certain products are subject to the terms and conditions of Xilinx's limited warranty, please refer to Xilinx's Terms of Sale which can be viewed at <https://www.xilinx.com/legal.htm#tos>; IP cores may be subject to warranty and support terms contained in a license issued to you by Xilinx. Xilinx products are not designed or intended to be fail-safe or for use in any application requiring fail-safe performance; you assume sole risk and liability for use of Xilinx products in such critical applications, please refer to Xilinx's Terms of Sale which can be viewed at <https://www.xilinx.com/legal.htm#tos>.

AUTOMOTIVE APPLICATIONS DISCLAIMER

AUTOMOTIVE PRODUCTS (IDENTIFIED AS "XA" IN THE PART NUMBER) ARE NOT WARRANTED FOR USE IN THE DEPLOYMENT OF AIRBAGS OR FOR USE IN APPLICATIONS THAT AFFECT CONTROL OF A VEHICLE ("SAFETY APPLICATION") UNLESS THERE IS A SAFETY CONCEPT OR REDUNDANCY FEATURE CONSISTENT WITH THE ISO 26262 AUTOMOTIVE SAFETY STANDARD ("SAFETY DESIGN"). CUSTOMER SHALL, PRIOR TO USING OR DISTRIBUTING ANY SYSTEMS THAT INCORPORATE PRODUCTS, THOROUGHLY TEST SUCH SYSTEMS FOR SAFETY PURPOSES. USE OF PRODUCTS IN A SAFETY APPLICATION WITHOUT A SAFETY DESIGN IS FULLY AT THE RISK OF CUSTOMER, SUBJECT ONLY TO APPLICABLE LAWS AND REGULATIONS GOVERNING LIMITATIONS ON PRODUCT LIABILITY.

© Copyright 2012-2017 Xilinx, Inc. Xilinx, the Xilinx logo, Artix, ISE, Kintex, Spartan, Virtex, Vivado, Zynq, UltraScale, and other designated brands included herein are trademarks of Xilinx in the United States and other countries. All other trademarks are the property of their respective owners. Simulink is a registered trademark of The MathWorks, Inc. AMBA, AMBA Designer, ARM, ARM1176JZ-S, CoreSight, Cortex, PrimeCell, and MPCore are trademarks of ARM in the EU and other countries. All other trademarks are the property of their respective owners.