

Numbering Systems

Introduction

The VHDL modeling language allows numbers being represented in several radix systems. The underlying digital circuit processes the number in binary, however, input into and output from such circuits is typically done using decimal numbers. In this lab you will learn various representations and methods for converting numbers from one representation into another. *Please refer to the Vivado tutorial on how to use the Vivado tool for creating projects and verifying digital circuits.*

Objectives

After completing this lab, you will be able to:

- Define a number in various radix
- Design combinatorial circuits capable of converting data represented in one radix into another
- Design combinatorial circuits to perform simple addition operation
- Learn a technique to improve addition speed

Number Representations

Part 1

VHDL defines a two valued bit and a bit vector. The IEEE standard defines multi-valued STD_LOGIC and STD_LOGIC_VECTOR. A defined signal can have the following four basic values:

- i. 0 : logic-0 or false
- ii. 1 : logic-1 or true
- iii. x : unknown
- iv. z : high-impedance

VHDL is case insensitive. A “z” value at the input of a gate or in expression is usually interpreted as a don't care or “x”. There are three types of constants in VHDL: (i) integer, (ii) real, and (iii) string. Integer numbers can be written in (i) simple decimal or (ii) base format. An integer in simple decimal form is specified as a sequence of digits with an optional + or a -. For example,

15
-32

Where 15 can be represented in binary as 01111 in 5-bit format and -32 can be represented in binary as 100000 in 6-bit format. The simple format representation may result in 32-bit hardware.

A number can be represented in the base format with syntax:

`<base> <value >`

Where *base* is one of o or O (for octal), b or B (for binary), x or X (for hexadecimal), and *value* is a sequence of digits which are valid for the specified base. Binary values can be declared in double quotations without needing to specify a base. The *value* must be unsigned. For example,

o"37" 5-bit octal representation
"1111" 4-bit binary
x"AA" 8-bit hexadecimal representation

If the vector variable is bigger than the value being assigned, then additional zeros will need to be concatenated to extend the bit count. For example:

```
signal counter : std_logic_vector (7 downto 0);    --An eight bit
                                                    vector is
                                                    declared.

...

counter <= "0000" & x"A";    --Hexadecimal "A" is "1010", counter is
                              eight bits, so four bits of zeros are
                              concatenated.
```

This is different from Verilog where zeros are automatically padded if there is a size mismatch while making a value assignment to a multi-bit signal.

1-1. Define a 4-bit number in the model and display it on the right most 7-segment display.

- 1-1-1. Open Vivado and create a blank project called *lab2_1_1*.
- 1-1-2. Create and add the VHDL module that defines a 4-bit number in binary format and displays the same on the right most 7-segment display. You may use the model developed in 4-2 of Lab 1 assuming that the number you define will be between 0 and 9.
- 1-1-3. Add the appropriate board related master XDC file to the project and edit it to include the related pins.
- 1-1-4. Synthesize and implement the design.
- 1-1-5. Generate the bitstream, download it into the Basys3 or the Nexys4 DDR board, and verify the functionality.

Binary Codes

Part 2

Although most processors compute data in binary form whereas the input-output is generally done in some coded form. Normally, we exchange information in decimal. Hence decimal numbers must be coded in terms of binary representations. In the simplest form of binary code, each decimal digit is replaced by its binary equivalent. This representation is called Binary Coded Decimal (BCD) or 8-4-2-1 (to indicate weight of each bit position). Because there are only ten decimal digits, 1010 through 1111 are not valid BCD. Table below shows some of the widely used binary codes for decimal digits. These codes are designed and used for communication reliability and error detection.

Decimal Digits	BCD (8-4-2-1)	6-3-1-1	Excess-3	2-out-of-5	Gray code
0	0000	0000	0011	00011	0000
1	0001	0001	0100	00101	0001
2	0010	0011	0101	00110	0011
3	0011	0100	0110	01001	0010
4	0100	0101	0111	01010	0110
5	0101	0111	1000	01100	1110
6	0110	1000	1001	10001	1010
7	0111	1001	1010	10010	1011
8	1000	1011	1011	10100	1001
9	1001	1100	1100	11000	1000

2-1. Output a 4-bit binary input number onto one LED (most significant bit) and the right most 7-segment display (least significant digit) after converting them into two-digit decimal equivalent (BCD). Use only dataflow modeling.

Design a circuit that converts a 4-bit binary number v into its 2-digit decimal equivalent, z and m . Since valid input range is between 0 and 15, the most significant digit can be displayed using one LED. Table below shows the required output values. A block diagram of the design is given in figure below. It includes a comparator that checks when the value of v is greater than 9, and uses the output of this comparator in the control of the 7-segment displays. Hint: The $m3$ would be zero whenever V is greater than binary 1001.

v[3:0]	z	m[3:0]
0000	0	0000
0001	0	0001
0010	0	0010
0011	0	0011
0100	0	0100
0101	0	0101
0110	0	0110
0111	0	0111
1000	0	1000
1001	0	1001
1010	1	0000
1011	1	0001
1100	1	0010
1101	1	0011
1110	1	0100
1111	1	0101

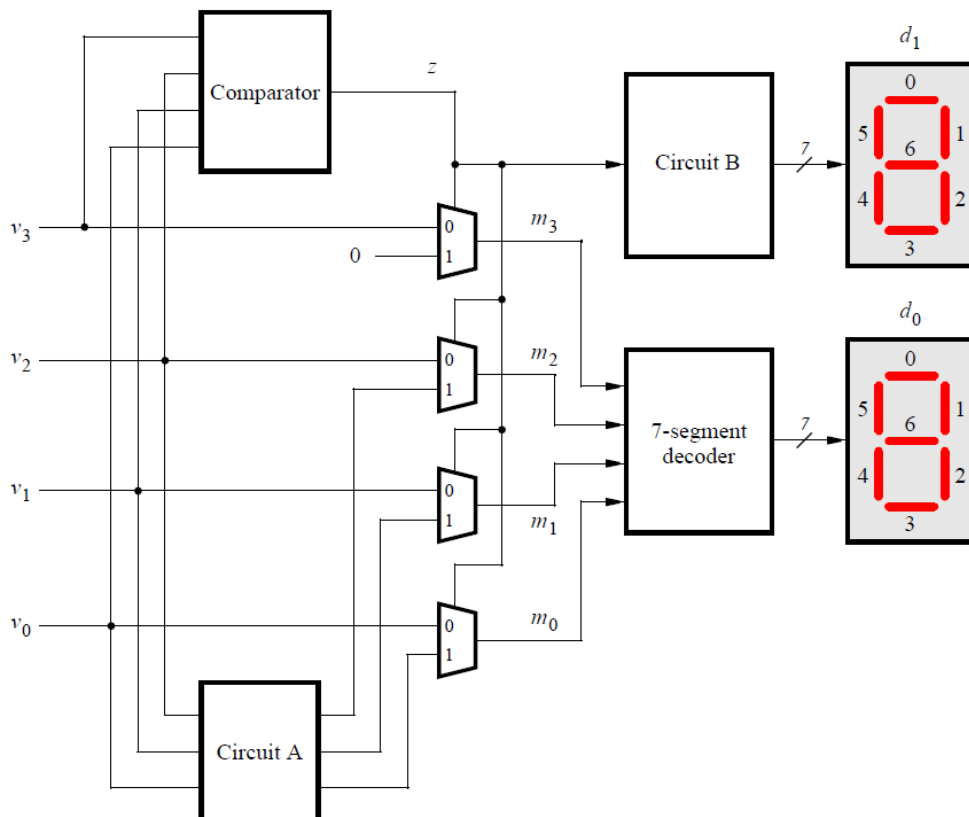

- 2-1-1. Open Vivado and create a blank project called *lab2_2_1*.
- 2-1-2. Create and add the VHDL module (name it as *lab2_2_1_partA*) with $v[3:0]$ input, and *z* and $m[3:0]$ output, instantiating *comparator_dataflow*, *lab2_circuitA_dataflow*, and *mux_2to1* and connecting them as necessary.
- 2-1-3. Model *comparator_dataflow* and *lab2_circuitA_dataflow* functionality using the dataflow constructs.
- 2-1-4. Add the provided testbench (*lab2_2_1_partA_tb.vhd*) to the project.
- 2-1-5. Simulate the design for 200 ns and verify the design works.
- 2-1-6. Extend the design by creating the top-level module (*lab2_2_1*) to have *bcdto7segment_dataflow* decoder (that you developed in Lab 1) and provide one 7-bit output *seg0* instead of *m*.
- 2-1-7. Add the appropriate board related master XDC file to the project and edit it to include the related pins. Assign *v* input to **SW3-SW0**, *z* to **LED0**, and *seg0* to 7-segment display cathodes, **CA-CG**, and assign **an** to the pins **J17, J18, T9, J14, P14, T14, K2, U13** (for Nexys4 DDR) or **U2, U4, V4, W4** (for Basys3).
- 2-1-8. Synthesize the design.
- 2-1-9. Implement the design.
- 2-1-10. Generate bitstream, download it in to the Basys3 or the Nexys4 DDR board, and verify the functionality. Please note that the most significant decimal digit is indicated by LED0 on the board.
- 2-2. Model a 2-out-of-5 binary code and display a 4-bit binary coded decimal input number onto five LEDs. Use dataflow modeling.**
- 2-2-1. Open Vivado and create a blank project called *lab2_2_2*.
- 2-2-2. Create and add a hierarchical design with 4-bit input ($x[3:0]$) and 5-bit output ($y[4:0]$). Use dataflow modeling statements only.
- 2-2-3. Add the appropriate board related master XDC file to the project and edit it to include the related pins. Assign **SW3-SW0** to *x* and **LED4-LED0** to *y*.
- 2-2-4. Synthesize and implement the design.
- 2-2-5. Generate bitstream, download it in to the Basys3 or the Nexys4 DDR board, and verify the functionality.

Performing Addition

Part 3

When two one-bit numbers are added, they may produce two bits output. For example, $1 + 1 = 10$ (all in binary). When you add three one-bit numbers the result will still be two bits, e.g. $1 + 1 + 1 = 11$. This simple operation can be viewed as adding two bits with carry in from the lower significant operation, resulting into sum and carry out- the left bit is carry out and the right bit is sum. Figure below shows a 4-bit adder. Since the carry is rippled from least significant bit position (c_{in}) to the most significant position (c_{out}), such adder is called ripple carry adder.

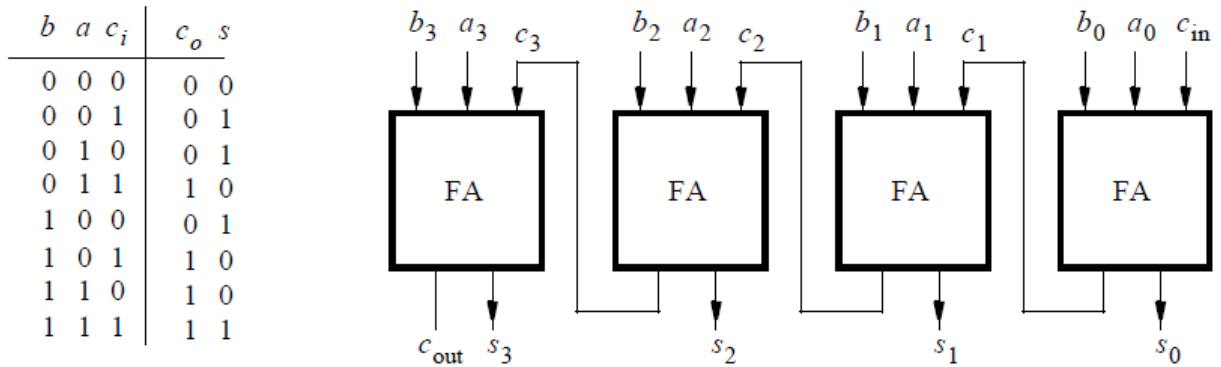

3-1. Create a 4-bit ripple carry adder using dataflow modeling.

- 3-1-1. Open Vivado and create a blank project called *lab2_3_1*.
 - 3-1-2. Create and add the VHDL module named *fulladder_dataflow* with three inputs (a , b , c_{in}) and two outputs (s and c_{out}) using dataflow modeling. All inputs and outputs should be one-bit wide.
 - 3-1-3. Add the provided testbench (*fulladder_dataflow_tb.vhd*) to the project.
 - 3-1-4. Simulate the design for 80 ns and verify that the design works
 - 3-1-5. Create and add the VHDL module to the project with three inputs (a , b , c_{in}) and two outputs (c_{out} and s) instantiating full adder (FA) four times and connecting them as necessary. The a , b , and s should be a 4-bit vector and c_{in} and c_{out} should each be one-bit wide.
 - 3-1-6. Add the appropriate board related master XDC file to the project and edit it to include the related pins. Assign a to **SW7-SW4**, b to **SW3-SW0**, s to **LED3-LED0**, c_{in} to **BTNU**, and c_{out} to **LED7**.
 - 3-1-7. Synthesize and implement the design.
 - 3-1-8. Generate bitstream, download it in to the Basys3 or the Nexys4 DDR board, and verify the functionality.
- ### 3-2. Modify the design of 3-1 by treating the 4-bit input as BCD, performing addition, generating result in BCD, and displaying it on LED0 and right most 7-segment display. Use switches to input two 4-bit BCD input and BTNU for carry-in. Reuse models developed in 2-1 and 3-1 as needed. Use dataflow modeling.

- 3-2-1. Open Vivado and create a blank project called *lab2_3_2*.

- 3-2-2.** Modify the project of 3-1 as necessary to perform the required function and outputting the result on LED0 and the right most 7-segment display.
- 3-2-3.** Add the appropriate board related master XDC file to the project and edit it to include the related pins. Use switches **SW73-SW0** to assign two 4-bit BCD input and **SW15** for carry in.
- 3-2-4.** Synthesize and implement the design.
- 3-2-5.** Generate bitstream, download it in to the Basys3 or the Nexys4 DDR board, and verify the functionality.

Improving Addition Speed

Part 4

The ripple-carry adders take a longer time to compute when two large numbers (e.g. 8, 16, 32 bits) are added. To reduce the computation time, another structure, called carry-lookahead adders (see figure below), can be used. It works by creating two signals (P and G) for each bit position, based on whether a carry is propagated through a less significant bit position (at least one input is a '1'), generated in that bit position (both inputs are '1'), or killed in that bit position (both inputs are '0'). After P and G are generated the carries for every bit position are created.

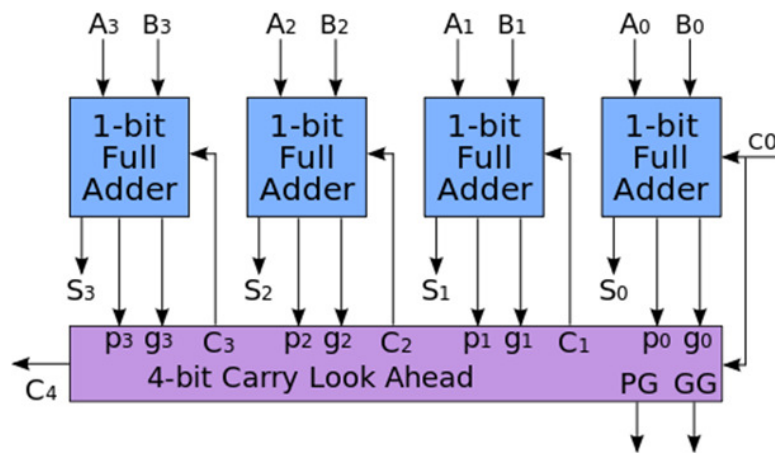

Where $P_i = A_i + B_i$ and $G_i = A_i B_i$. Within Carry Look Ahead unit, $C_{i+1} = G_i + P_i C_i$. The speed-up is achieved through the fact that C_i being generated at the same time irrespective of i^{th} position.

4-1. Create a carry-look ahead adder circuit by modifying the project of 3-1 and using dataflow modeling.

- 4-1-1.** Open Vivado and open the project you had created in 3-1.
- 4-1-2.** Modify the project of 3-1 as necessary to perform the addition of two four-bit numbers using the carry look-ahead structure and outputting the result LEDs. Provide carry-in through BTNU. Hint: You will need to modify FA to output P_i and G_i , and then create and add another module CLA to perform the carry look ahead function (takes c_0 and $p_i g_i$ ($i=0$ to 3) and outputs c_4 and p_g and g_g).
- 4-1-3.** Modify the XDC file to provide input b through **SW3-SW0**, a through **SW7-SW4**, c_{in} through **BTNU**. Output c_{out} through **LED7** and sum through **LED3-LED0**.
- 4-1-4.** Synthesize and implement the design.

- 4-1-5.** Generate bitstream, download it in to the Basys3 or the Nexys4 DDR board, and verify the functionality.

Conclusion

In this lab, you learned how to define numbers in various radix systems. You also designed various number conversion circuits using dataflow modeling. You also learned a technique of improving addition speed.