

Versal ACAP System Software Developers Guide

UG1304 (v2021.1) June 16, 2021

Revision History

The following table shows the revision history for this document.

Section	Revision Summary
06/16/2021 Version 2021.1	
Chapter 6: Software Design Paradigms	Updated the Asymmetric Multiprocessing section.
Chapter 7: Boot and Configuration	Updated chapter.
Chapter 8: Platform Loader and Manager	Updated PLM Error Codes , XilLoader/IPI CDO Commands , and PLM Build Flags sections.
Chapter 10: Versal ACAP Platform Management	Added Event Management Framework section. Updated Implementing Power Management on a Processor Unit , PM Features in Linux , Arm Trusted Firmware , PS Management Controller Firmware , and Relationship with PLM sections.

Table of Contents

Revision History	2
Chapter 1: Overview	6
Introduction to Versal ACAP.....	6
Navigating Content by Design Process.....	7
About This Guide.....	8
Chapter 2: Programming View of Versal ACAP	10
Hardware Overview.....	11
Chapter 3: Development Tools	21
Vivado Design Suite.....	21
Vitis Software Platform.....	22
PetaLinux Tools.....	26
Device Tree Generator.....	27
Open Source.....	28
Linux Software Development Using Yocto.....	29
QEMU.....	31
AI Engine Development Environment.....	34
Chapter 4: Software Stack	37
Bare-Metal Software Stack.....	37
Linux Software Stack.....	40
Third-Party Software Stack.....	43
Chapter 5: Software Development Flow	44
Bare-Metal Application Development in the Vitis Environment	45
Linux Application Development Using PetaLinux Tools.....	46
Linux Application Development Using the Vitis Software Platform.....	47
Chapter 6: Software Design Paradigms	50
Frameworks for Multiprocessor Development.....	50
Symmetric Multiprocessing.....	51

Asymmetric Multiprocessing	53
Chapter 7: Boot and Configuration.....	58
Versal ACAP Boot Process.....	58
Boot Flow.....	63
Boot Device Modes.....	66
Fallback Boot and MultiBoot.....	69
Programmable Device Image.....	71
Configuration Data Object.....	72
Boot Image (PDI) Creation.....	73
Methods for Copying the PDI to a Primary Boot Device.....	75
Chapter 8: Platform Loader and Manager	76
PLM Boot and Configuration.....	76
PLM Software Details.....	80
PLM Errors.....	85
PLM Event Logging.....	93
PLM Interface (XilPLMI).....	100
XilLoader.....	103
XilPM.....	109
XilSecure.....	110
XilSEM.....	110
PLM Usage.....	111
Services Flow.....	113
Chapter 9: Security.....	114
Security Features.....	114
Asymmetric Hardware Root-of-Trust (A-HWRoT) (Authentication Required).....	117
Encryption.....	118
Symmetric Hardware Root-of-Trust (S-HWRoT) Boot Mode (Encryption Required).....	119
Chapter 10: Versal ACAP Platform Management.....	120
Versal ACAP Platform Management Overview.....	121
Versal ACAP Power Domains.....	121
Versal DFX Management.....	124
Versal ACAP Platform Management Software Architecture.....	126
API Calls and Responses.....	128
Event Management Framework.....	152
XilPM Client Implementation Details.....	155

PM Features in Linux.....	158
Arm Trusted Firmware.....	160
Power State Coordination Interface.....	162
PS Management Controller Firmware.....	163
Relationship with PLM.....	164
Chapter 11: Target Development Platforms.....	166
Boards and Kits.....	166
Appendix A: Libraries.....	167
Appendix B: Additional Resources and Legal Notices.....	168
Xilinx Resources.....	168
Documentation Navigator and Design Hubs.....	168
References.....	168
Please Read: Important Legal Notices.....	170

Overview

Introduction to Versal ACAP

Versal™ adaptive compute acceleration platforms (ACAPs) combine Scalar Engines, Adaptable Engines, and Intelligent Engines with leading-edge memory and interfacing technologies to deliver powerful heterogeneous acceleration for any application. Most importantly, Versal ACAP hardware and software are targeted for programming and optimization by data scientists and software and hardware developers. Versal ACAPs are enabled by a host of tools, software, libraries, IP, middleware, and frameworks to enable all industry-standard design flows.

Built on the TSMC 7 nm FinFET process technology, the Versal portfolio is the first platform to combine software programmability and domain-specific hardware acceleration with the adaptability necessary to meet today's rapid pace of innovation. The portfolio includes six series of devices uniquely architected to deliver scalability and AI inference capabilities for a host of applications across different markets—from cloud—to networking—to wireless communications—to edge computing and endpoints.

The Versal architecture combines different engine types with a wealth of connectivity and communication capability and a network on chip (NoC) to enable seamless memory-mapped access to the full height and width of the device. Intelligent Engines are SIMD VLIW AI Engines for adaptive inference and advanced signal processing compute, and DSP Engines for fixed point, floating point, and complex MAC operations. Adaptable Engines are a combination of programmable logic blocks and memory, architected for high-compute density. Scalar Engines, including Arm® Cortex®-A72 and Cortex-R5F processors, allow for intensive compute tasks.

The Versal AI Edge series focuses on AI performance per watt for real-time systems in automated drive, predictive factory and healthcare systems, multi-mission payloads in aerospace & defense, and a breadth of other applications. More than just AI, the Versal AI Edge series accelerates the whole application from sensor to AI to real-time control, all with the highest levels of safety and security to meet critical standards such as ISO26262 and IEC 61508.

The Versal AI Core series delivers breakthrough AI inference acceleration with AI Engines that deliver over 100x greater compute performance than current server-class of CPUs. This series is designed for a breadth of applications, including cloud for dynamic workloads and network for massive bandwidth, all while delivering advanced safety and security features. AI and data scientists, as well as software and hardware developers, can all take advantage of the high-compute density to accelerate the performance of any application.

The Versal Prime series is the foundation and the mid-range of the Versal platform, serving the broadest range of uses across multiple markets. These applications include 100G to 200G networking equipment, network and storage acceleration in the Data Center, communications test equipment, broadcast, and aerospace & defense. The series integrates mainstream 58G transceivers and optimized I/O and DDR connectivity, achieving low-latency acceleration and performance across diverse workloads.

The Versal Premium series provides breakthrough heterogeneous integration, very high-performance compute, connectivity, and security in an adaptable platform with a minimized power and area footprint. The series is designed to exceed the demands of high-bandwidth, compute-intensive applications in wired communications, data center, test & measurement, and other applications. Versal Premium series ACAPs include 112G PAM4 transceivers and integrated blocks for 600G Ethernet, 600G Interlaken, PCI Express® Gen5, and high-speed cryptography.

The Versal architecture documentation suite is available at: <https://www.xilinx.com/versal>.

Navigating Content by Design Process

Xilinx® documentation is organized around a set of standard design processes to help you find relevant content for your current development task. All Versal™ ACAP design process [Design Hubs](#) can be found on the Xilinx.com website. This document covers the following design processes:

- **System and Solution Planning:** Identifying the components, performance, I/O, and data transfer requirements at a system level. Includes application mapping for the solution to PS, PL, and AI Engine.
 - [Chapter 5: Software Development Flow](#)
 - [Chapter 6: Software Design Paradigms](#)
 - [Chapter 7: Boot and Configuration](#)
 - [Chapter 8: Platform Loader and Manager](#)
 - [Chapter 9: Security](#)
 - [Chapter 10: Versal ACAP Platform Management](#)
 - [Chapter 11: Target Development Platforms](#)

- **Embedded Software Development:** Creating the software platform from the hardware platform and developing the application code using the embedded CPU. Also covers XRT and Graph APIs.
 - [Chapter 5: Software Development Flow](#)
 - [Chapter 3: Development Tools](#)
 - [Chapter 4: Software Stack](#)
 - [Chapter 6: Software Design Paradigms](#)
-

About This Guide

This guide focuses on the Versal ACAP system software development environment, and is the first document that software developers should read. This document includes the following:

- **Chapter 2: Programming View of Versal ACAP:** Provides an overview of system software, and relevant aspects of the Versal ACAP hardware.
- **Chapter 3: Development Tools:** Describes the available Xilinx tools and flows for programming the Versal device.
- **Chapter 4: Software Stack:** Provides an overview of the various software stacks available for the Versal devices.
- **Chapter 5: Software Development Flow:** Explains the bare-metal software development for the real-time processing unit (RPU) and the application processing unit (APU) using the Vitis™ IDE, as well as Linux software development for the APU using PetaLinux and Vitis tools.
- **Chapter 6: Software Design Paradigms:** Describes the Xilinx Versal device architecture that supports heterogeneous multiprocessor engines for different tasks.
- **Chapter 7: Boot and Configuration:** Presents the type of boot modes that Versal ACAP supports, along with an overview of the boot and configuration process for both secure and non-secure boot modes.
- **Chapter 8: Platform Loader and Manager:** Explains the role of the platform loader and manager (PLM) that runs on the platform processing unit (PPU) in the platform management controller (PMC). The PLM performs boot and configuration of the Versal ACAP, and then continuously monitors services after the initial boot and configuration of the Versal device.
- **Chapter 9: Security:** Details the Versal device features that you can leverage to address security during boot time and run time of an application.
- **Chapter 10: Versal ACAP Platform Management:** Describes the role of the platform management in managing resources, such as power, clock, reset, and pins optimally.

- **Chapter 11: Target Development Platforms:** Describes the boards and kits available for Versal ACAP.
- **Appendix A: Libraries:** Details the libraries and APIs available for Versal ACAP.

Programming View of Versal ACAP

Versal™ ACAP devices include five types of programmable processors. Each type of processor provides different computation capabilities to meet different requirements of the overall system:

- **Arm® Cortex®-A72 dual-core processor in the processor system (PS):** Typically used for control-plane applications, operating systems, communications interfaces, and lower level or complex computations.
- **Arm Cortex-R5F dual-core processor in the PS:** Typically used for applications requiring safety and determinism.
- **MicroBlaze™ processors in the programmable logic (PL):** (Optional) Typically used for data manipulation and transport, non-vector-based computation, and interfacing to the PS and other components on Versal ACAP.
- **ROM control unit (RCU) and PMC processing unit (PPU) units in the PMC:** Typically used for executing the PLM code.
- **AI Engines:** Typically used for compute-intensive functions in vector implementations.

Another key block in Versal ACAP is the PMC. Typically used for executing PLM code. This block is responsible for boot, configuration, partial-reconfiguration, and life cycle management tasks such as security. For more information about PMC management of boot and partial reconfiguration, see [Chapter 7: Boot and Configuration](#).

This chapter briefly discusses:

- PS with dual-core Cortex-A72 and dual-core Cortex-R5F processors
- MicroBlaze processor in the PL
- Linux and bare-metal software stacks used with the processors
- Boot and configuration information
- Additional features relevant to a software engineer

For details about additional features such as the PMC, DDR bus width, number of DDR memory controllers, interconnect for CCIX and PCIe (CPM), and PCI Express®, see the *Versal Architecture and Product Data Sheet: Overview* ([DS950](#)). The *Versal ACAP Technical Reference Manual* ([AM011](#)) includes details on PMC/PS-centric content with a hardware architecture section that includes links to documents that describe other integrated hardware and peripherals including the CPM, DDR, AI Engine, PL, and more.

Hardware Overview

This section provides an overview of the Versal ACAP hardware view components.

Note: For more detailed information about the Versal ACAP hardware, refer to the *Versal ACAP Technical Reference Manual* ([AM011](#)).

Figure 1: System-level Interconnect Architecture

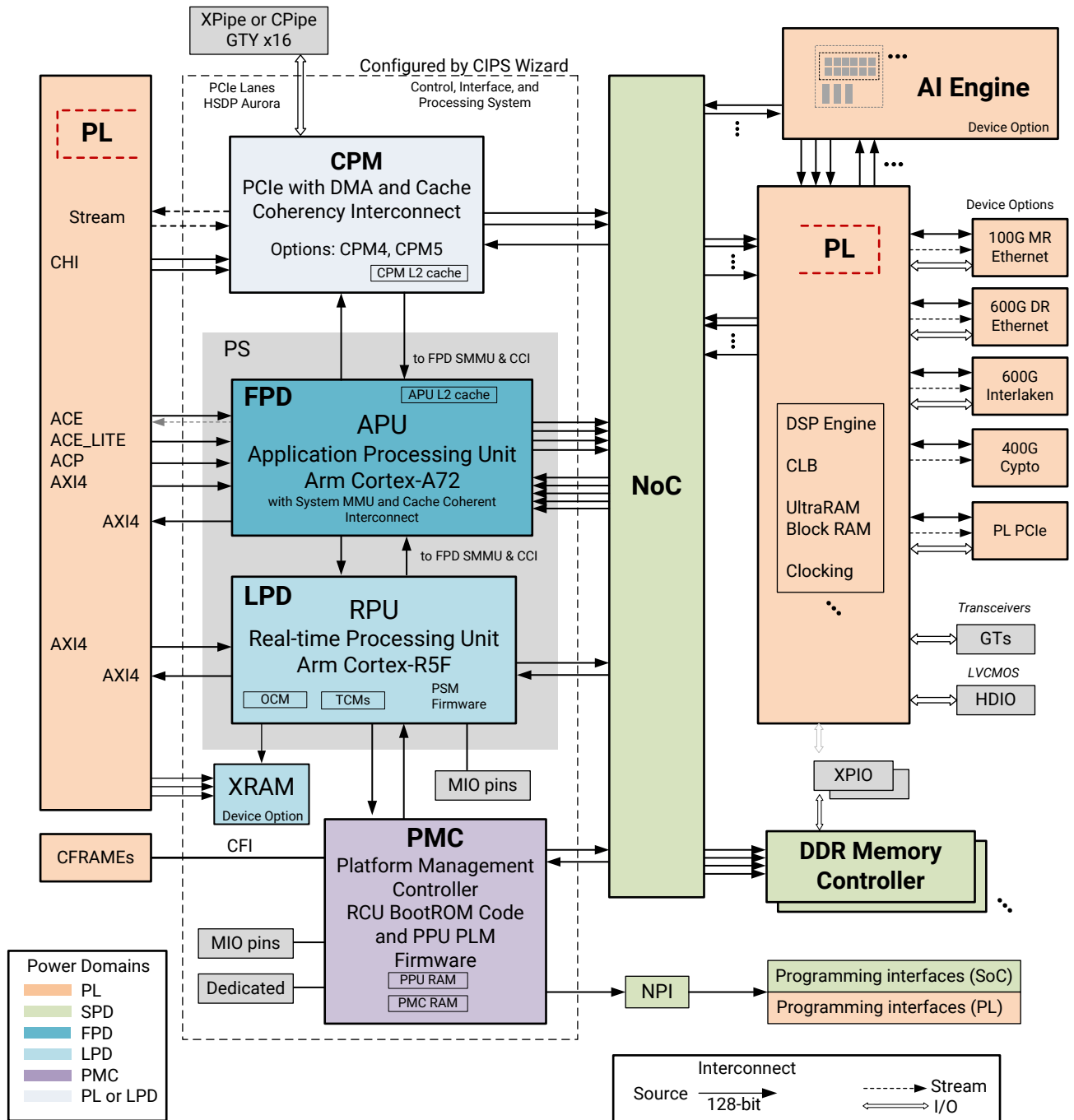

X24257-061021

Key Hardware Components

The following list describes the largest hardware view components:

- **AI Engine:** The AI Engine is used for custom acceleration and compute engines.

- **APU:** The application processing unit (APU) consists of Cortex-A72 processor cores, L1/L2 caches, and related functionality. The Cortex-A72 cores and caches are part of Arm MPCore IP.

Versal ACAP uses a dual-core Cortex-A72 processor system with 1 MB L2 cache. The Cortex-A72 cores implement Armv8 64-bit architecture. The Cortex-A72 MPCore does not have integrated generic interrupt controller (GIC), so an external GIC IP is used. For more information, refer to "APU Processor Features" in *Versal ACAP Technical Reference Manual* ([AM011](#)).

- **AXI Interconnect:** The Advanced eXtensible Interface interconnect connects one or more AXI memory-mapped master devices to one or more memory-mapped slave devices. The AXI interfaces conform to the AMBA® AXI version 4 specifications from Arm, including the AXI4-Lite control register interface subset.
- **CPM:** The interconnect for Cache Coherent Interconnect for Accelerators (CCIX) and PCIe® (CPM) module is the primary PCIe interface for the processing system. There are two integrated blocks for PCIe in the CPM, supporting up to Gen4 x16. You can configure both of the integrated blocks for PCIe as an endpoint. Furthermore, you can configure each integrated block as a root port that contains direct memory access (DMA) logic. The CPM also incorporates CCIX functionality to allow a PL accelerator to act as a CCIX compliant accelerator.
- **PL:** The programmable logic (PL) is a scalable structure that includes adaptable engines and intelligent engines that can be used to construct accelerators, processors, or almost any other complex functionality. It is configured using the Vivado® tools. The architect determines the components to be available in the PL design. For example, the MicroBlaze processor is just an IP core, so you can optionally add MicroBlaze processors to the design. For more info, refer to "Programmable Logic" in *Versal ACAP Technical Reference Manual* ([AM011](#)).
- **PMC:** The platform management controller (PMC) handles device management control functions such as device reset sequencing, initialization, boot, configuration, security, power management, dynamic function eXchange (DFX), health-monitoring, and error management. You can boot the device in either secure or non-secure mode. For more information, refer to "Platform Management Controller" in *Versal ACAP Technical Reference Manual* ([AM011](#)).
- **NoC Interconnect:** The NoC is the main interconnect and contains a vertical component (VNoC) and a horizontal component (HNoC).
 - HNoC is integrated in the horizontal super row/region (HSR). The HSR includes blocks such as XPIO, hard DDR memory controller, PLL, System Monitor satellites, HBM, and AI Engine.
 - VNoC integration includes global-clk-column and System Monitor satellites. In SSI technology, VNoCs are connected across super logic region (SLR) boundaries. Microbumps and buffers for this reside in the Thin-HNoC. Configuration data between SSI technology master and slaves travels over the NoC.

- **RPU:** The real-time processing unit (RPU) is a dual-core Cortex-R5F processor, based on the Armv7-R architecture, which can run as either two independent cores or in a lock-step configuration. For more information, refer to Platform Management in *Versal ACAP Technical Reference Manual* ([AM011](#)).

Additional Hardware Components

- **Peripheral Controllers:** The input/output units (IOPs) present in the PS module contains the low speed peripherals in low power domain (LPD) and high-speed peripherals in full power domain (FPD). Some IOPs are present in the PMC power domain (PPD) peripherals.

For more information, refer to "I/O Peripherals" in *Versal ACAP Technical Reference Manual* ([AM011](#)).

- **Interconnects and Buses:** Versal ACAP has following additional interconnects and buses:

- **NPI:** The NoC programming interface, a 32-bit programming interface to the NoC and several attached units.

For more information, refer to *Versal ACAP Programmable Network on Chip and Integrated Memory Controller LogiCORE IP Product Guide* ([PG313](#)).

- **APB:** The advanced peripheral (APB) bus is a 32-bit single-word read/write bus interface. This bus is used to access control registers in the functional units, i.e., subsystem units. These control registers are used to program the functional units. The APB switch is used as the main switch in the following four areas:

- PMC
- LPD
- FPD
- CPM

- **CFI:** The configuration frame interface (CFI) transports the configuration information contained in the boot image from the PMC to its destination within the Versal device. CFI provides a dedicated high-bandwidth 128-bit bus to PL for configuration and readback. For more information, refer "CFI" in *Versal ACAP Technical Reference Manual* ([AM011](#)).

- **System Watchdog Timer:** The system watchdog (SWDT) timer is used to detect and recover from various malfunctions. The watchdog timer can be used to prevent system lockup (when the software becomes trapped in a deadlock). For more information, refer to "System Watchdog Timer" in *Versal ACAP Technical Reference Manual* ([AM011](#)).

- **Clocks:** Versal ACAP has the following clocks:

- PMC and PS clocks
- CPM clocks
- NoC, AI Engine, and DDR memory controller clocks

- **PL clocks:** The PL includes its own clock arrays that are programmed when blocks are instantiated. The PL also includes programmable clock modules that can be driven by clocks from input pins and other sources.

For more information, see the *Versal ACAP Clocking Resources Architecture Manual* ([AM003](#)).

- **Memory:** Versal device has following list of memories:
 - **DDR Memory:** Up to 12 GB of RAM is supported. This DDR memory is external to the device.
 - **On-chip memory (OCM) in the PS:** This memory is 256 KB in size, and is also accessible by the RPU.
 - **Tightly coupled memory (TCM) in the RPU:** This memory is 256 KB and is mainly used by the RPU but can be accessed by the APU.
 - **Battery-backed RAM (BBRAM):** This memory stores the advanced encryption standard (AES) 256-bit key.
 - **eFUSE:** 2,048 bits of user memory that stores multiple keys and security configuration settings.
- **Reset:** Versal ACAP has several layers of resets with overlapping effects. The highest-level resets are generally aligned with power domains, then power island resets, and finally the individual functional unit resets. In some cases, functional units have local resets that affects part of the block. The reset hierarchy:
 - Subsystem resets (power domains)
 - Power-island resets
 - Functional unit (block) resets
 - Partial resets of a block (some cases)

For more information, refer to the "Resets" section in *Versal ACAP Technical Reference Manual* ([AM011](#)).

- **Virtualization:** The Versal device includes the following three hardware components for virtualization:
 - CPU virtualization
 - Memory virtualization
 - Interrupt virtualization

For more information, refer to "Memory Virtualization" in *Versal ACAP Technical Reference Manual* ([AM011](#)).

- **Security and Safety:** The Versal device has the following security management and safety features:

- Secure key storage and management
- Tamper monitoring and response
- User access to Xilinx hardware cryptographic accelerators
- Xilinx memory protection unit (XMPU) and Xilinx peripheral protection unit (XPPU) provides hardware-enforced isolation.
- TrustZone

For more information, refer to "Platform Management Controller" in *Versal ACAP Technical Reference Manual (AM011)* and also [Chapter 9: Security](#). For XMPU and XPPU, refer to "Memory Protection" in *Versal ACAP Technical Reference Manual (AM011)*.

Processing System

The processing system (PS) has the following components:

- Dual-core Arm Cortex-A72 processor with 1 MB L2 cache with error correction code (ECC)
- Dual 32-bit Cortex-R5F processor cores based on the Arm® v7-R architecture and supports both RPU with 128 KB TCM with error correction code (ECC) and Single Lockstep R5 with 256 KB TCM with ECC.
- 256 KB on-chip memory with error correction code (ECC)
- Arm CoreSight™ debug and trace (DAP) with TMC, STM, ATM, and APM
- System memory management unit (SMMU)
- CCI
- One universal serial bus (USB) 2.0
- PCIe RP/EP in CPM (device dependent)
- Two gigabit Ethernet MAC with TSN support
- One low-power domain DMA (LPD-DMA)
- Performance I/O
- Two controller area network-flexible data rates (CAN-FD), two serial peripheral interfaces (SPI), two I2C, and two UART controllers
- PS management controller (PSM)

Note: The PS has access to shared external DDR memory.

Application Processing Unit

The application processing unit (APU) consists of an Arm Cortex-A72 processor, L1/L2 caches, and related functionality. The Cortex-A72 cores and caches are part of the Arm processor MPCore IP, with integrated L1 and L2 caches.

The Versal device uses a dual-core Cortex-A72 with 1 MB L2 cache.

The Cortex-A72 cores implement Armv8 64-bit architecture. The Cortex-A72 MPCore processor does not have an integrated generic interrupt controller (GIC), so an external GIC IP is used.

The APU includes the following features:

- Dual-core Cortex-A72 core class with 1 MB L2 with error correction code (ECC). The L1 caches include I-cache of 48 KB in size and for I-cache and D-cache of 32 KB in size. L1 caches include error correction code (ECC).
- GIC-500 interrupt controller
- Per core power-gating support
- TrustZone support

Real-Time Processing Unit

The Versal ACAP APU provides improved performance at an improved safety level. However, for real-time applications which require a higher level of safety (e.g., ASIL-C/SIL3), reliability, and determinism, real-time processing unit (RPU) is used with a lockstep processor subsystem.

The RPU architecture specification consists of RPU cores, TCMs, and on-chip memory. The following list describes the main RPU features.

- Dual 32-bit Cortex-R5F cores based on Arm v7-R architecture and supports lock-step or split mode options
- 128 KB TCM per Cortex-R5F processor in split mode.
- Option to combine 256 KB of TCM in lock-step mode.
- 256 KB of on-chip memory with error correction code (ECC) accessible by both the RPU and the APU.
- 32 KB L1 instruction cache with error correction code (ECC) or parity and 32 KB L1 data cache with error correction code (ECC)
- Generic interrupt controller (GIC) to support GIC architecture
- Per lock-step power-gating support
- TCM and OCM power-gating
- TrustZone aware

Tightly Coupled Memory Interface

The per-core TCM can be configured for the following modes:

- **Split, performance mode:** While running the RPU in split mode, each core can only access 128 KB of TCM.

- **Lock-step, safety mode:** While running in the lock-step mode, the RPU has access to the entire 256 KB of TCM.

RPU Configuration Options

The following table and figure describe the four configuration options of the RPU.

Table 1: RPU Configuration Options

Configuration Option	Description	Core Running
Option 1: Split mode	High-performance mode. In this configuration, both real-time cores work independently, each using separate TCMs.	RPU core 0 and RPU core 1
Option 2: Split mode, only one core used	High-performance mode. In this configuration, RPU core 0 can be held in reset, while RPU core 1 runs independently using all 256 KB of TCM.	RPU core 1 only
Option 3: Lock-step mode	Safety mode. Note: The lock-step mode is typically used for safety-critical deterministic applications. In this configuration, both cores run in parallel with each other, with integrated comparator logic. The RPU core 0 is the master, and RPU core 1 is the checker. The TCM is combined to give RPU core 0 a larger TCM. Each core executes the same code. The inputs and outputs of the two cores are compared. If they do not match, then the comparator detects the error. While two cores are used, the performance is of one core.	RPU core 0 only
Option 4: None	RPU is not used.	None

Notes:

1. RPU core 0 TCM is the tightly coupled memory associated with Cortex-R5F core 0 core in split mode; RPU core 1 TCM is the tightly-coupled memory associated with the RPU_0 core in split mode.
2. RPU core 1 TCM is located slightly farther from the cores than RPU core 0 TCM, so there might be a slightly longer delay when cores access RPU core 1 TCM versus RPU core 0 TCM.

RPU cores can use the system watchdog timer (SWDT) to monitor functionality and check performance, through a periodic write to a timer register.

Figure 2: RPU Configuration Options

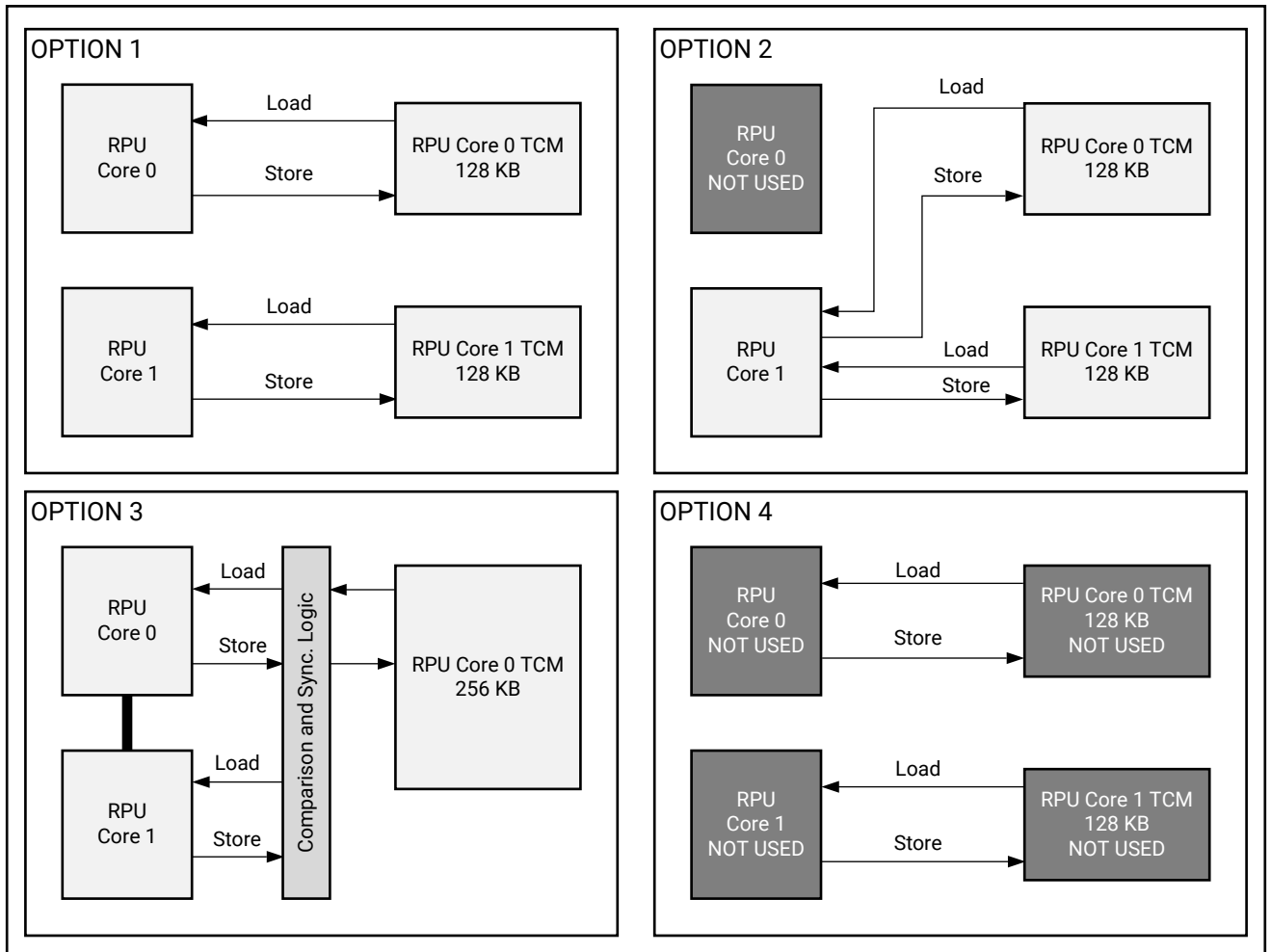

X22497-041719

The following figure shows the resource sharing when the RPU cores are configured in lock-step mode.

Figure 3: RPU Cortex-R5F Processor Lock-step Mode

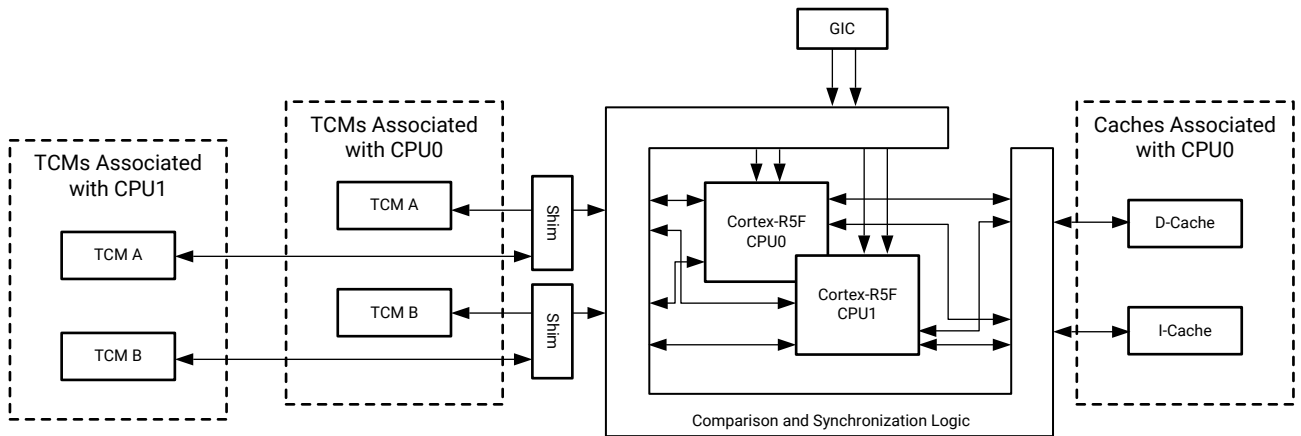

X15295-050919

Programmable Logic

You can use the Vivado IP integrator to configure the Versal ACAP programmable logic (PL). The PL is flexible, and the configuration uses building blocks or integrated components to create a customized design.

The PL is a complex structure that includes integrated and instantiated hardware accelerators, controllers, memories, and miscellaneous functional units.

- Integrated functional units include a multi-gigabit Ethernet MAC.
- Building blocks are used to instantiate functional units, and connect the integrated units to the interconnect and I/O structures. Building blocks include DSP, block RAM, UltraRAM, and clocking structures.
- Instantiated functional units are built using the PL integrated building blocks and could include:
 - **Interconnects:** AXI, NoC interconnect
 - **Platform control components:** PS configuration and reset
 - **Digital functional units:** Adders, counters, floating point unit (FPU), and video
 - **Radio frequency-oriented (RF) functional units:** RF usage functional units, long term evolution (LTE), and radio

MicroBlaze Processors in the Programmable Logic

Optionally, architects can add MicroBlaze processors into the PL design. These MicroBlaze processors can run a variety of software, including Linux, bare-metal applications, FreeRTOS, or other custom software.

Development Tools

This chapter focuses on Xilinx[®] tools and flows that are available for programming Versal™ ACAP. It also provides a brief description about the available open source tools that you can use for open source development on different processors of Versal ACAP.

A comprehensive set of tools for developing and debugging software applications on the Versal device includes:

- Hardware IDE
- Software IDE
- Compiler toolchain
- Debug and trace tools
- Simulators (for example, Quick Emulator (QEMU))
- Models and virtual prototyping tools (for example, emulation board platforms)

The following sections provide a summary of the available Xilinx development tools.

Vivado Design Suite

The Xilinx Vivado[®] Design Suite contains tools that are encapsulated in the Vivado IDE. The IDE provides an intuitive GUI with powerful features.

The tools deliver a SoC-strength, IP- and system-centric, development environment built exclusively by Xilinx to address the productivity bottlenecks in system-level integration and implementation.

All commands and command options in the Vivado Design Suite use the native tool command language (Tcl) format, which can run on both, the Vivado IDE or the Vivado Design Suite Tcl shell. Analysis and constraint assignment is enabled throughout the design process. For example, you can run timing or power estimations after synthesis, placement, or routing. As the database is accessible through Tcl, changes to constraints, design configuration, or tool settings happen in real time, often without forcing re-implementation.

The Vivado IDE uses a concept of opening designs in memory. Opening a design loads the design (an ASCII file defining the components and their connections) at that particular stage of the design flow, assigns the constraints to the design, and then applies the design to the target device. This provides the ability to visualize and interact with the design at each design stage.

You can improve design performance and ease of use through the features delivered by the Vivado Design Suite, including:

- The control, interfaces, and processing system IP (CIPS) configuration within IP integrator with graphical user interfaces to let you create and modify the CIPS within the IP integrator block design.
- Register transfer level (RTL) design in VHDL, Verilog, and SystemVerilog
- Quick integration and configuration of IP cores from the Xilinx IP catalog to create block designs through the Vivado IP integrator
- Vivado synthesis
- C-based sources in C, C++, and SystemC
- Vivado implementation for place and route
- Vivado serial I/O and logic analyzer for debugging
- Vivado power analysis
- Synopsys design constraints (SDC)-based Xilinx design constraints (XDC) for timing constraints entry
- Static timing analysis
- Flexible floorplanning
- Detailed placement and routing modification
- Vivado Tcl Store, which you can use to add to and modify the capabilities in the Vivado tool

You can download the Vivado Design Suite from [Vivado Design Suite – ML Editions](#).

Vitis Software Platform

Versal ACAP designs are enabled by the Vitis™ tools, libraries, and IP. The Vitis IDE lets you program, run, and debug the different elements of a Versal ACAP AI Engine application, which can include AI Engine kernels and graphs, PL, high-level synthesis (HLS) IP, RTL IP, and PS applications. For detailed information on the Vitis IDE tool flow, refer to *Chapter 4: Design Flow in Versal ACAP Design Guide* ([UG1273](#)).

The Vitis software platform supports the following flows for software development:

- [Accelerated Flow](#)

- [Embedded Flow](#)

Accelerated Flow

For acceleration, the Vitis development environment lets you build a software application using the OpenCL™ or the open source Xilinx Runtime (XRT) native API to run the hardware kernels on accelerator cards, such as the Xilinx Alveo™ Data Center accelerator cards. The Vitis core development kit also supports running the software application on a Linux-embedded processor platform such as Versal ACAP.

For the embedded processor platform, the Vitis execution model also uses the OpenCL™ API and the Linux-based XRT to schedule the hardware kernels and control data movement.

The Vitis tools support the Alveo PCIe-based cards, as well as the ZCU102 Base, ZCU102 Base with dynamic function eXchange (DFX), ZCU104 base, ZC702 base, ZC706 base embedded processor platforms, and the Versal ACAP VCK190 base and VMK180 base boards.

In addition to these off-the-shelf platforms, the Vitis tools support custom platforms.

The Vitis development environment supports application development for both data center and embedded processor platforms, allowing you to migrate data center applications to embedded platforms. The Vitis tool includes the `v++` compiler for the hardware kernel on all platforms, the `g++` compiler for compiling the application to run on an x86 host, and Arm® compiler for cross-compiling the application to run on the embedded processor of a Xilinx device.

Note: The `v++` compiler has two options: compile (that is `v++ -c` to Vitis HLS), system linking (`v++ -l`), and packaging (`-p`).

For more information, see the [Vitis Accelerated Software Development Flow Documentation](#) in the Application Acceleration Development flow of the *Vitis Unified Software Platform Documentation* (UG1416).

Embedded Flow

Based on the open source Eclipse platform, the Vitis development environment provides a complete environment for creating software applications that are targeted for Xilinx embedded processors. The environment includes a GNU-based compiler toolchain, C/C++ development toolkit (CDT), JTAG debugger, flash programmer, middleware libraries, bare-metal BSPs, and drivers for Xilinx IP. The development environment also includes a robust IDE for C/C++ bare-metal and Linux application development and debugging.

The development environment lets you create software applications using a unified set of Xilinx tools for the Arm Cortex®-A72 and Cortex®-R5F processors, as well as the Xilinx MicroBlaze™ processors. The environment provides the following methods to create applications:

- Bare-metal and FreeRTOS applications for MicroBlaze processors

- Bare-metal, Linux, and FreeRTOS applications for APU
- Bare-metal and FreeRTOS applications for RPU
- User customization of PLM, which is primarily used to boot Versal ACAP
- Library examples are provided with Vitis (ready to load sources and build), as follows:
 - OpenCV
 - OpenAMP RPC
 - FreeRTOS “HelloWorld”
 - LWIP
 - Performance tests (Dhrystone, memory tests, peripheral tests)
 - Cryptographic hardware engine access
 - eFUSE and BBRAM programming
 - PLM

After a hardware design is created in the Vivado IDE, you can export a block design along with hardware design and bitstream files to the Vitis tool export directory directly from the Vivado Project Navigator.

All processes necessary to successfully complete this export process are run automatically. The Vitis tool process exports the following files to the Vitis tool directory:

- `.xpr`: Vivado project file
- `psv_init.tcl`, `psv_init_gpl.c`, `psv_init.c`, `psv_init.h`: Contain information required during PLM creation
- `psv_init.html`: Versal ACAP register summary viewer
- `.xsa`: Xilinx [Support Archive](#) for the design.

The Vitis environment can also generate:

- Programmable device image (PDI) for secure and non-secure boot for the following processors:
 - Arm Cortex-A72
 - Arm Cortex-R5F
 - MicroBlaze

The Vitis environment supports Linux application development and debugging.

For more information, see [Vitis Embedded Software Development Flow Documentation](#) in the *Vitis Unified Software Platform Documentation* (UG1416).

Vitis Tools

The Vitis development environment provides the following tools for use in Xilinx embedded software development:

- **Xilinx System Debugger (XSDB):** Provides a command line interface to the Xilinx `hw_server`. The `hw_server` is the backend tool, that provides device/processor level debug capabilities to front-end tools such as XSDB, and the Vitis IDE. XSDB also provides various low-level debugging features not directly available in the Vitis development environment.
- **Flash programmer:** Used for programming the software application images into external flash devices including QSPI, OSPI, or eMMC.
- **Linker script generator:** Used for mapping your bare-metal/FreeRTOS application elf sections across the hardware memory space.
- **GNU compiler tool suite:** Includes tools such as the GNU compiler collection (GCC), AS, LD, and binutils that are used for compilation on all Xilinx processors.
- **Bootgen:** Used for generating the boot image known as the PDI.
- **Performance analysis tools:** Includes GPROF, TCF Profiler, and OProfile.
- **Debug/download tools:** Includes GNU debugger (GDB), XSDB, and flash writer.
- **Simulator:** QEMU
- **Xilinx software command-line tool (XSCT):** Xilinx Software Command-line Tool (XSCT) is an interactive and scriptable command-line interface to the Vitis IDE. As with other Xilinx tools, the scripting language for XSCT is based on the tools command language (Tcl). The tools helps to abstract away and group most of the common functions into logical wizards that even the novice can use.

However, scriptability of a tool is also essential for providing the flexibility to extend what is done with that tool. It is particularly useful when developing regression tests that will be run nightly or running a set of commands that are used often by the developer.

You can run XSCT commands interactively or script the commands for automation. XSCT supports the following actions:

- Create hardware, domains, platform projects, system projects, and application projects
- Manage repositories
- Set toolchain preferences
- Configure and build domains/BSPs and applications

- Download and run applications on hardware targets
- Create and flash boot images by running `Bootgen` and `program_flash` tools

This reference content is intended to provide the information you need to develop scripts for software development and debug targeting Xilinx processors.

For more information, refer to [Xilinx Software Command-Line Tool](#) in the Embedded Software Development flow of the *Vitis Unified Software Platform Documentation* (UG1416).

The Vitis tool provides a separate perspective for each task to ease the software development process. Perspectives available for C/C++ developers are as follows:

- **Design perspective views:** View, create and build the software C/C++ projects. By default, it consists of an editor area and other views, such as Vitis projects, C/C++ projects to show the software projects present in the workspace, a navigation console, properties, tasks, make targets, outline, and search.
- **Debug view:** Helps debug software applications. You can customize the open source applications from the debug perspective and integrate with the Vitis environments.
- **Remote system explorer:** Connect and work with a variety of remote systems, for example, running Linux on a Versal device.

PetaLinux Tools

PetaLinux offers tools to customize, build, and deploy embedded Linux solutions on Xilinx processing systems. Tailored to accelerate design productivity for SoC devices, the solution works with the Xilinx hardware design tools to facilitate the development of open source Linux systems for Versal devices.

PetaLinux tools include the following:

- Build tools, such as GNU, `petalinux-build`, and `make` to build the kernel images and the application software.
- Debug tools, such as GNU debugger (GDB), `petalinux-boot`, and Oprofile for profiling. The following partial list shows the supported PetaLinux toolchain:
 - **GNU `gcc/g++` toolchain:** Xilinx Arm GNU tools.
 - `petalinux-build`: Used to build software image files.
 - **Make:** Make build for compiling the applications.
 - **GDB:** GDB tools for debugging.
 - `petalinux-package`: Used to create the boot image.
 - `petalinux-boot`: Used to boot Linux.

- **QEMU:** Emulator platform for the Versal device.
- **Oprofile:** Used for profiling.

The following figure shows the PetaLinux tool flow.

Figure 4: PetaLinux Tool-Based Flow

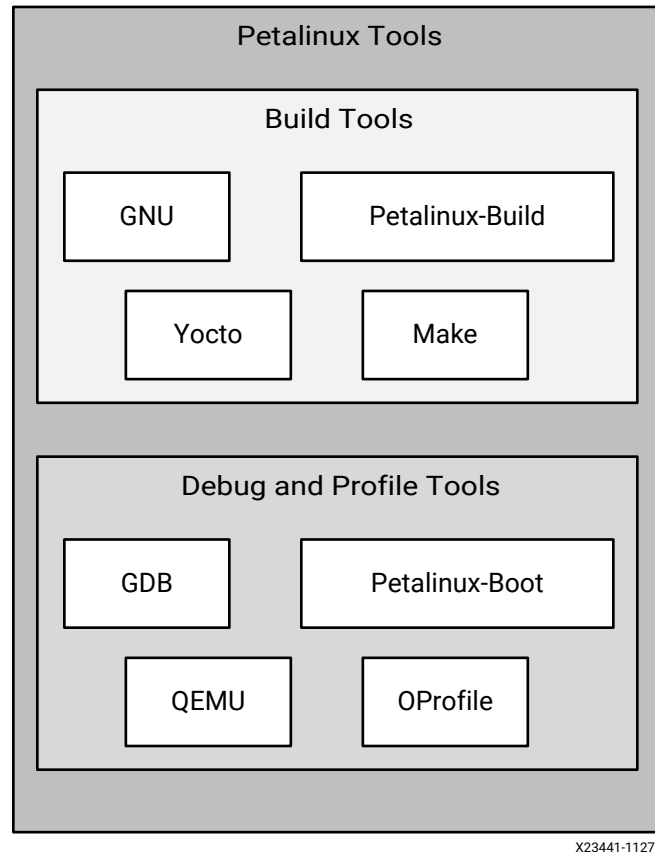

For more information, refer to the following:

- *PetaLinux Tools Documentation: Reference Guide* ([UG1144](#))
- <https://xilinx-wiki.atlassian.net/wiki/spaces/A/pages/18842250/PetaLinux> on the Xilinx Wiki.

Device Tree Generator

The device tree (DT) data structure consists of nodes with properties that describe a hardware device. The Linux kernel uses the device tree to support a wide range of hardware configurations.

It is also possible to have various combinations of peripheral logic, each using a different configuration. For all the different combinations, the device tree generator (DTG) generates the .dts/.dtsi device tree files.

The following is a list of the dts/dtsi files generated by the device tree generator:

- `pl.dtsi`: Contains all the memory mapped peripheral logic (PL) IPs.
- `pcw.dtsi`: Contains the dynamic properties for the PS IPs.
- `system-top.dts`: Contains the memory, boot arguments, and command line parameters.
- `versa1.dtsi`: Contains the PS-specific and CPU information.
- `versa1-clk.dtsi`: Contains the clocks and power domain information for PS peripherals. For more information, see <https://xilinx-wiki.atlassian.net/wiki/spaces/A/pages/18842279/Build+Device+Tree+Blob> on the Xilinx Wiki.

Open Source

The Arm GNU open source Linaro GCC toolchain is adopted for the Xilinx software development platform. The GNU tools for Linux hosts are available as part of the Vitis environment. This section details the open source GNU tools and Linux tools available for the processing clusters in Versal ACAPs.

Xilinx Arm GNU Tools

The following Xilinx Arm GNU tools are available for compiling software for the APU, the RPU, and the embedded MicroBlaze processors:

- `arm-linux-gnueabi-hf-gcc`: Used for compiling Armv8 C code into 32-bit Linux applications with hard floating point instructions.
- `arm-linux-gnueabi-hf-g++`: Used for compiling Armv8 C++ code into 32-bit Linux applications.
- `aarch64-linux-gnu-gcc`: Used for compiling Armv8 C code into 64-bit Linux applications.
- `aarch64-linux-gnu-g++`: Used for compiling Armv8 C++ code into 64-bit Linux applications.
- `aarch64-none-elf-gcc`: Used for compiling Armv8 C code into 64-bit RTOS and bare-metal applications.
- `aarch64-none-elf-g++`: Used for compiling Armv8 C++ code into 64-bit RTOS and bare-metal applications.
- `armr5-none-eabi-gcc`: Used for compiling Armv7 C code into 32-bit RTOS and bare-metal applications.

- `armr5-none-eabi-g++`: Used for compiling Armv7 C++ code into 32-bit RTOS and bare-metal applications.
- `microblaze-xilinx-elf-gcc`: Used for compiling MicroBlaze™ C code.
- `microblaze-xilinx-elf-g++`: Used for compiling MicroBlaze™ C++ code.

Note: All GNU compilers are packaged with their associated assembler, linker, etc.

Linux Software Development Using Yocto

Xilinx distributes open source, meta-xilinx Yocto/OpenEmbedded recipes on <https://github.com/Xilinx>, so you can work with in-house Yocto build systems to configure, build, and deploy Linux for Versal devices.

The meta-xilinx layer also provides a number of BSPs for Xilinx reference boards and vendor boards, such as ZC702, ZCU102, Ultra96, Zedboard, VCK190, and VMK180.

The meta-xilinx layer is compatible with Yocto/OpenEmbedded, adding recipes for various components. For more information, see <https://git.yoctoproject.org/cgit/cgit.cgi/meta-xilinx/>.

You can develop Linux software on the Arm Cortex-A72 processor using open source Linux tools. This section explains the Linux Yocto tools and its project development environment.

The following table lists the Yocto distribution.

Table 2: Yocto Distribution

Distribution Type	Name	Description
Yocto Build System	Bitbake	Generic task execution engine that allows shell and Python tasks to be run efficiently, and in parallel, while working within complex inter-task dependency constraints.
Yocto Profile and Trace Packages	Perf	Profiling and tracing tool that comes bundled with the Linux Kernel.
	Ftrace	Refers to the ftrace function tracer but encompasses a number of related tracers along with the infrastructure used by all the related tracers.
	Oprofile	System-wide profiler that runs on the target system as a command-line application.
	Sysprof	System-wide profiler that consists of a single window with three panes, and buttons, which allow you to start, stop, and view the profile from one place.
	Blktrace	A tool for tracing and reporting low-level disk I/O.

Yocto Project Development Environment

The Yocto Project development environment allows Linux software to be developed for Versal ACAP through Yocto recipes distributed on <https://github.com/Xilinx>. You can use components from the Yocto project to design, develop, and build an open source-based Linux software stack.

The following figure shows the complete Yocto project development environment. The Yocto project has wide range of tools which can be configured to download the latest Xilinx kernel and build with some enhancements made locally in the form of local projects.

You can also change the build and hardware configuration through BSP.

Yocto combines a rich compiler and quality analyzing tools to build and test images. After the images pass the quality tests and package feeds required for Vitis tool generation are received, the Yocto distribution launches Vitis environment for application development.

The important features of the Yocto project are as follows:

- Provides a recent Linux kernel along with a set of system commands and libraries suitable for the embedded environment.
- Makes available system components such as X11, GTK+, Qt, Clutter, and SDL (among others), so you can create a rich user experience on devices that have display hardware. For devices that do not have a display or where you want to use alternative UI frameworks, these components do not need to be installed.
- Creates a focused and stable core compatible with the OpenEmbedded project to easily and reliably build and develop Linux software.
- Supports a wide range of hardware and device emulation through the QEMU.

Figure 5: Yocto Project Development Environment

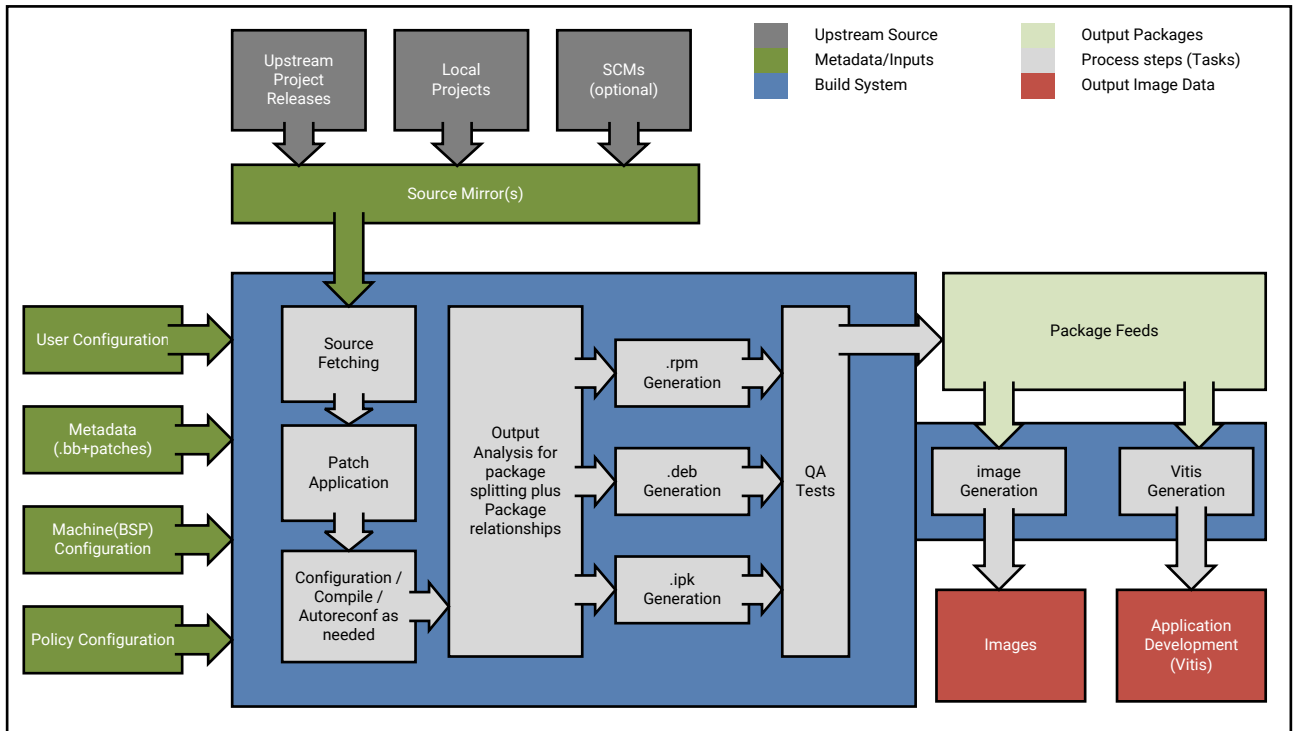

X14841-062420

You can download the Yocto tools and the Yocto Project development environment from the <https://www.yoctoproject.org/software-overview/downloads/>.

For more information about Xilinx-supported Yocto features, see Yocto Features in *PetaLinux Tools Documentation: Reference Guide* (UG1144) and the <https://xilinx-wiki.atlassian.net/wiki/spaces/A/pages/18841883/Yocto> on the Xilinx Wiki.

QEMU

QEMU is a fast functional and instruction accurate emulator that can be installed on both Linux and Windows hosts. The Xilinx QEMU features a large number of the same peripheral models as Xilinx silicon and can even inject real data from the host into emulation (for example, Ethernet, UART, storage, CAN-FD, etc.) to stimulate your applications. Xilinx has provided QEMU as a development platform for many generations including Versal ACAP, Zynq UltraScale+ MPSoC, Zynq-7000, and MicroBlaze processors.

The Xilinx QEMU is already integrated in Vitis, PetaLinux, and Yocto in every Xilinx release. For the most up to date development branch, you can download Xilinx QEMU, build and install from source.

To use this emulation platform you must be familiar with:

- Device architecture
- GNU debugger (GDB) for remote debugging
- Generation of guest software applications using Yocto, Xilinx PetaLinux and Vitis tools
- Linux Device Trees

This document focuses on the list of features supported for the emulation of Versal ACAP in Xilinx QEMU. The purpose of this section is to familiarize software application developers, system software developers, system hardware designers, and validation/verification designers with the basic information to use and debug software with QEMU.

QEMU Model for Versal ACAP

The Xilinx Versal ACAP QEMU model supports the following resources:

- Central Processing Units (CPUs)
 - Application Processing Unit (APU): 2 x Arm Cortex-A72 processor.
 - Real-time Processing Unit (RPU): 2 x Arm Cortex-R5F processor.
- PS management controller (PSM): 1 x MicroBlaze processor
- Platform Management Controller (PMC)
 - Platform processing unit (PPU) 0 (MicroBlaze processor)
 - Platform processing unit (PPU) 1 (MicroBlaze processor)
- Memory
 - On-chip memory (OCM)
 - Tightly coupled memory (TCM)
 - DDR memory
 - Accelerator RAM (XRAM)
- Security Modules
 - Device Key Storage
 - Battery Backed Random Access Memory (BBRAM)
 - eFUSE (Electronic Fuse)
 - Physical Unclonable Function (PUF - API Only)
 - Crypto Primitives
 - Advanced Encryption Standard - Galois/Counter Mode (AES-GCM)

- Secure Hash Algorithm 3 (SHA-3)
- RSA-4096
- Elliptic Curve Digital Signature Algorithm (ECDSA)
- Peripheral and Controllers
 - 2 x Serial Peripheral Interface (SPI)
 - Octal SPI (OSPI)
 - OSPI DMA
 - 2 x SD
 - eMMC
 - 2 x CANFD
 - 2 x UART
 - 3 x Inter-Integrated Circuit (I2C)
 - 2 in PS
 - 1 in PMC
 - 2 x Gigabit Ethernet
 - 4 x triple timer counter (TTC)
 - Inter-processor interrupt (IPI)
 - (Xilinx Memory Protection Unit (XMPU)
 - (Xilinx Peripheral Protection Unit (XPPU)
 - System Memory Management Unit (SMMU)
 - General interrupt controller (GIC) v3
 - Direct memory access (DMAs)
 - Real-Time Clock (RTC)
 - USB (Host Mode Only)

Using the QEMU

For more information on using the QEMU, see the [Xilinx Quick Emulator User Guide: QEMU](#).

AI Engine Development Environment

The Versal AI Core series delivers breakthrough AI inference acceleration with AI Engines that deliver over 100x greater compute performance than current server-class CPUs. This series is designed for a breadth of applications, including cloud for dynamic workloads and network for massive bandwidth, all while delivering advanced safety and security features. AI and data scientists, as well as software and hardware developers, can all take advantage of the high compute density to accelerate the performance of any application. Given the AI Engine's advanced signal processing compute capability, it is well-suited for highly optimized wireless applications such as radio, 5G, backhaul, and other high-performance DSP applications.

AI Engines are an array of very-long instruction word (VLIW) processors with single instruction multiple data (SIMD) vector units that are highly optimized for compute-intensive applications, specifically digital signal processing (DSP), 5G wireless applications, and artificial intelligence (AI) technology such as machine learning (ML).

AI Engines provide multiple levels of parallelism including instruction-level and data-level parallelism. Instruction-level parallelism includes a scalar operation, up to two moves, two vector reads (loads), one vector write (store), and one vector instruction that can be executed—in total, a 7-way VLIW instruction per clock cycle. Data-level parallelism is achieved via vector-level operations where multiple sets of data can be operated on a per-clock-cycle basis. Each AI Engine contains both a vector and scalar processor, dedicated program memory, local 32 KB data memory, access to local memory in any of three neighboring directions. It also has access to DMA engines and AXI4 interconnect switches to communicate via streams to other AI Engines or to the programmable logic (PL) or the DMA. Refer to the *Versal ACAP AI Engine Architecture Manual* ([AM009](#)) for specific details on the AI Engine array and interfaces.

Xilinx® provides device drivers and libraries for user applications to access the Versal™ AI Engines. See *Versal ACAP AI Engine Programming Environment User Guide* ([UG1076](#)) to learn how to use the Xilinx® AI Engine program environment. The Vitis IDE lets you compile, simulate, and debug the different elements of a Versal ACAP AI Engine application. For detailed information on the Vitis IDE tool flow, refer to *Versal ACAP Design Guide* ([UG1273](#)). For detailed information on the Vitis AI Engine Tools and Flows, refer to *Versal ACAP AI Engine Programming Environment User Guide* ([UG1076](#)).

The following sections describe the software stack of the AI Engine.

AI Engine Software Development Flow

The AI Engine application comprises kernels that run on the AI Engine tiles, and a control application that runs on the CPU. The following figure shows the flow of the AI Engine control application and ELF generation.

Figure 6: AI Engine Software Development Flow

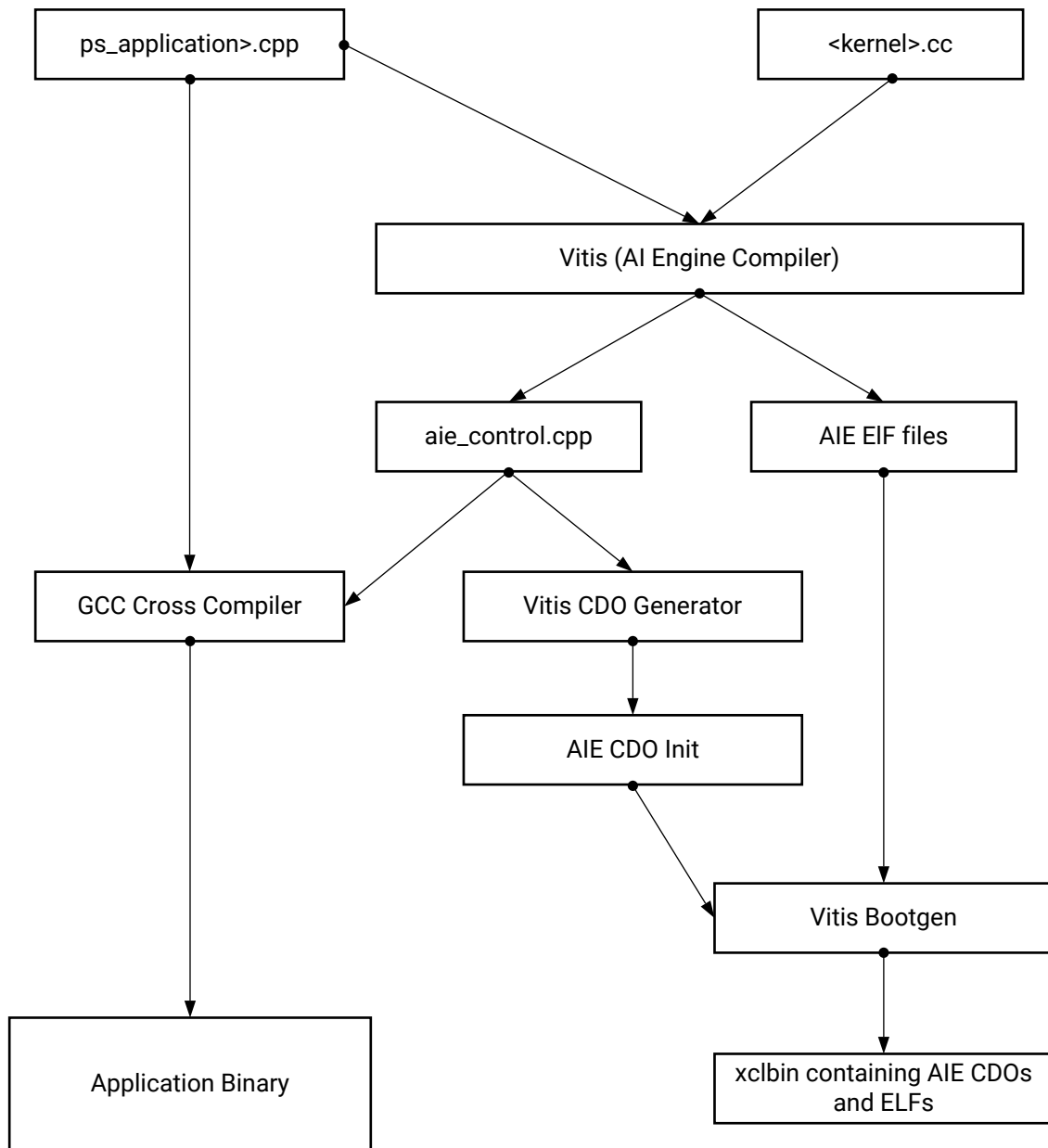

X25138-041421

You define the `<graph>.cpp` and `<kernels>.cpp`. The AI Engine compiler takes these inputs to generate `aie_control.cpp`, which runs on either the APU or RPU to configure and monitor the AI Engine and the ELF files that run on the AI Engine tiles.

AI Engine Runtime Stack

Your PS applications can call system libraries to access AI Engine registers and load the kernel ELF files.

- **Bare-Metal:** Your application can use the `cardano_api.a` library to access AI Engine registers. The `cardano_api.a` library calls `aie_control` and the AI Engine driver, to access the AI Engine register and device memory.

Figure 7: AI Engine Bare-Metal Runtime Stack

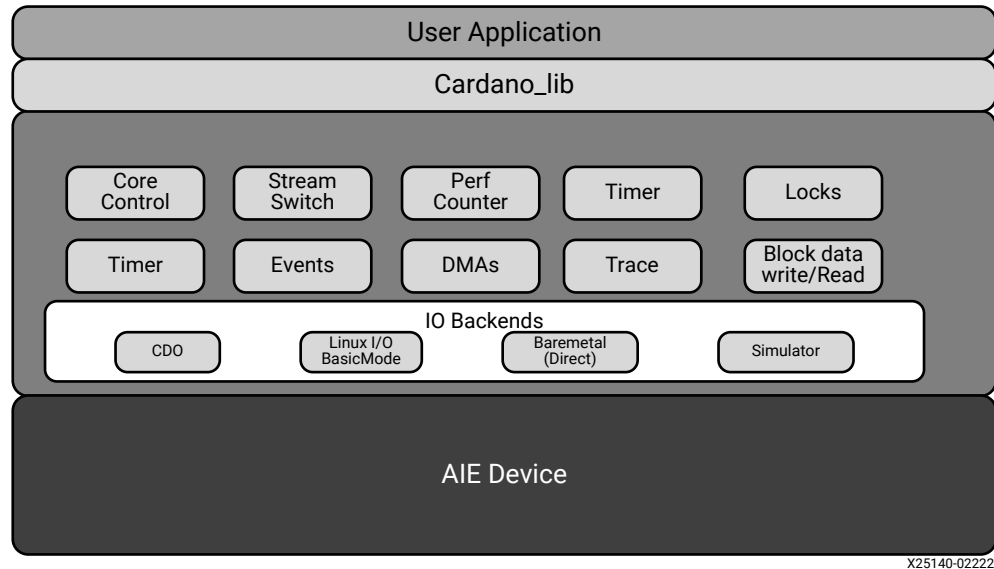

- **Linux:** On Linux, an application can use AI Engine driver APIs or XRT APIs to interact with the AI Engine.

Figure 8: AI Engine Linux Runtime Stack

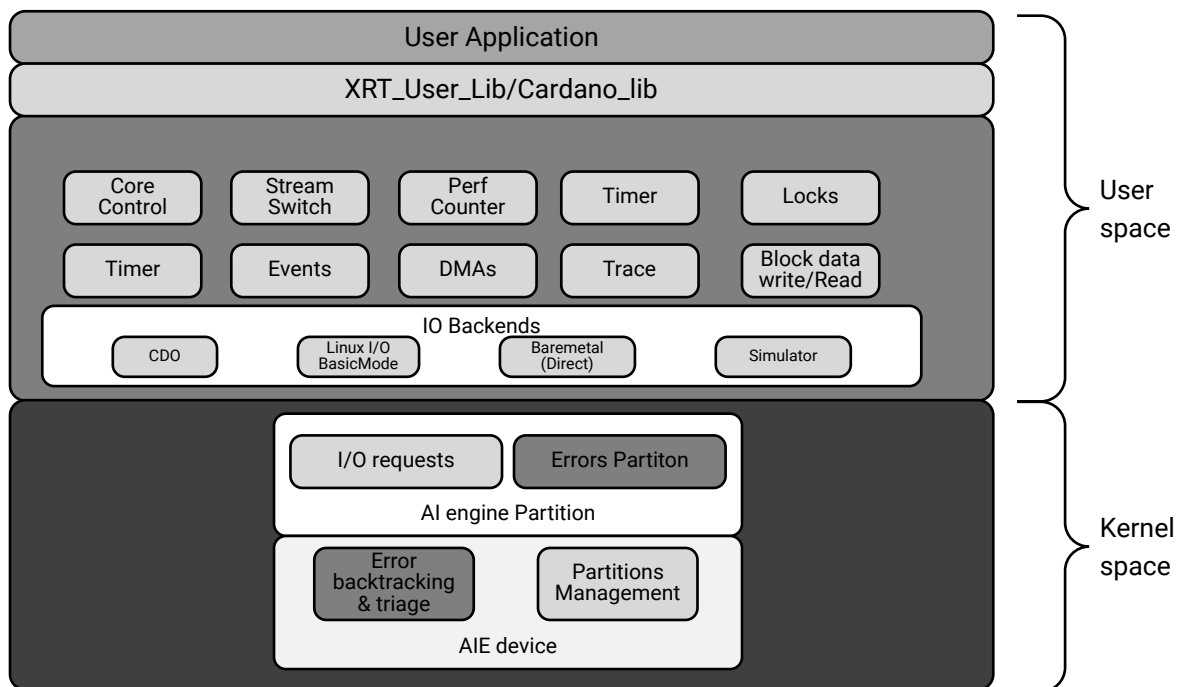

Software Stack

This chapter provides an overview of the bare-metal, Linux, and FreeRTOS software stacks available for the Versal™ devices. Many third-party software stacks can also be used on Versal devices. For more information, refer to [Embedded Software & Ecosystem](#) page.

For more information about various software development tools used with the device, see [Chapter 3: Development Tools](#).

For more information about bare-metal and Linux software application development, see [Chapter 5: Software Development Flow](#).

Bare-Metal Software Stack

Xilinx® provides a bare-metal software stack as part of the Vitis™ tools. The standalone software includes a simple, single-threaded environment that provides project domains such as standard input/output, and access to processor hardware features. The included board support packages (BSPs) and included libraries can be configured to provide the necessary functionality with the least overhead. You can locate the standalone drivers at the following path:

```
<Xilinx Installation Directory>\Vitis\<version>\data\embeddedsw  
\XilinxProcessorIPLib\drivers
```

You can locate libraries in the following path:

```
<Xilinx Installation Directory>\Vitis\<version>\data\embeddedsw\lib  
\sw_services
```

The following figure illustrates the bare-metal software stack in the APU.

Figure 9: Bare-Metal Software Development Stack

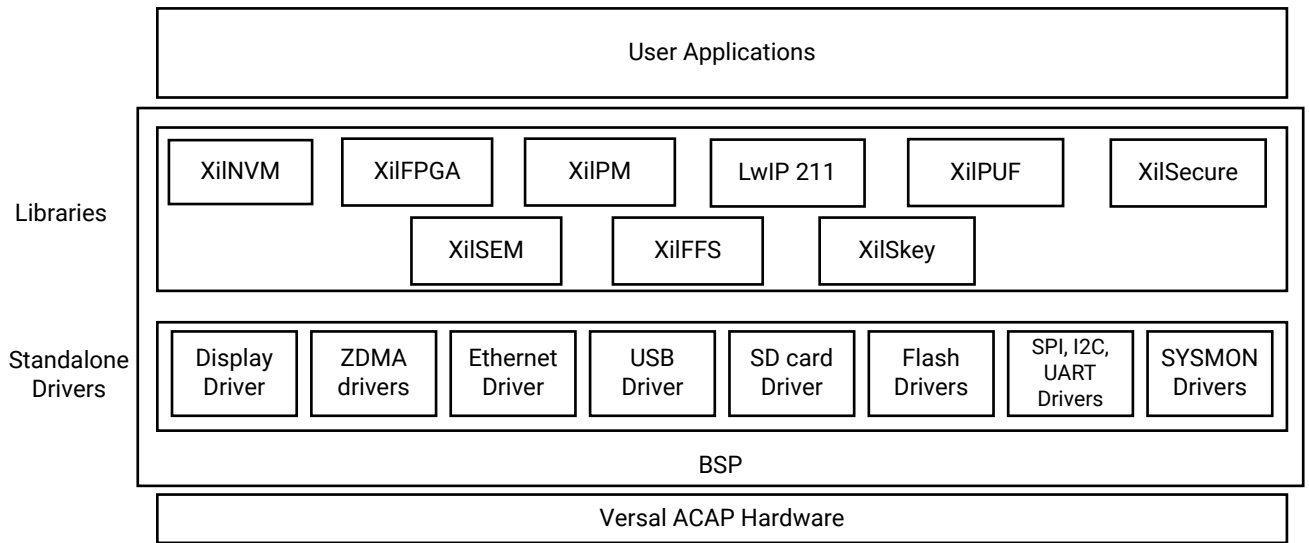

X23437-060721

Note: The software stack of libraries and drivers layer for bare-metal in the RPU is same in the APU.

The bare-metal stack key components include:

- Software drivers for peripherals including core routines needed for using the Arm® Cortex®-A72, and the Cortex-R5F processors in the PS, and MicroBlaze™ processors in the PL.
- Bare-metal drivers for PS peripherals and optional PL peripherals.
- Standard C libraries: libc and libm, based on the open source Newlib library, ported to the Cortex-A72, Cortex-R5F, and the MicroBlaze processors.
- Embedded Libraries:
 - **LwIP 211:** Describes the SDK port of the third party networking library, Light Weight IP (lwIP) for embedded processors.
 - **XilFFS:** XilFFS is a generic FAT file system that is primarily added for use with SD/eMMC driver. The file system is open source and a glue layer is implemented to link it to the SD/eMMC driver.
 - **XilSecure:** Provides APIs to access secure hardware on the Zynq UltraScale+ MPSoCs.
 - **XilSkey:** Provides a programming mechanism for user-defined eFUSE bits and for programming the KEY into battery-backed RAM (BBRAM) of Zynq-7000 SoC, provides programming mechanisms for eFUSE bits of UltraScale devices.
 - **XilIPM:** The Zynq UltraScale+ MPSoC and Versal ACAP power management framework is a set of power management options, based upon an implementation of the extensible energy management interface (EEMI).
 - **XilFPGA:** Provides an interface to the Linux or bare-metal users for configuring the PL over PCAP from PS. The library is designed for Zynq UltraScale+ MPSoC and Versal ACAP to run on top of Xilinx standalone BSPs.

- **XIISEM:** The Xilinx Soft Error Mitigation (XIISEM) library is a pre-configured, pre-verified solution to detect and optionally correct soft errors in Configuration Memory of Versal ACAPs.
- Additional middleware libraries that provide networking, file system, and encryption support.
- Application examples include test applications.

The C Standard Library (libc)

The libc library contains standard functions that C programs can use. The following header files are included in the libc library:

- `alloca.h`: Allocates space in the stack.
- `assert.h`: Diagnostics code
- `ctype.h`: Character operations
- `errno.h`: System errors.
- `inttypes.h`: Integer type conversions
- `math.h`: Mathematics
- `setjmp.h`: Non-local go to code
- `stdint.h`: Standard integer types
- `stdio.h`: Standard I/O facilities
- `stdlib.h`: General utilities functions
- `time.h`: Time function

The C Standard Library Mathematical Functions (libm)

The following table lists the libm mathematical C modules.

Table 3: libm Modules by Function Types and Listing

Function Type	Supported Functions
Algebraic	cbirt, hypot, sqrt
Elementary transcendental	asin, acos, atan, atan2, asinh, acosh, atanh, exp, expm1, pow, log, log1p, log10, sin, cos, tan, sinh, cosh, tanh
Higher transcendentals	j0, j1, jn, y0, y1, yn, erf, erfc, gamma, lgamma, and gamma_ramma_r
Integral rounding	ceil, floor, rint

Table 3: libm Modules by Function Types and Listing (cont'd)

Function Type	Supported Functions
IEEE standard recommended	copysign, fmod, ilogb, nextafter, remainder, scalbn, and fabs
IEEE classification	isnan
Floating point	logb, scalb, significand
User-defined error handling routine	matherr

Standalone BSP

Standalone BSP is a simple, low-level software layer. This layer provides access to basic processor features, such as caches, interrupts and exceptions and the basic features of a hosted environment, such as standard input and output, profiling, abort, and exit.

The following libraries are a small number of those available with standalone BSP:

- Xilinx fat file system (XilFFS) library
- XilMailbox library
- Xilinx Power Management (XilPM)
- Xilinx Soft Error Mitigation (XilSEM) library
- Lightweight IP (lwIP)

For more information on the available libraries, refer to [Appendix A: Libraries](#) and *OS and Libraries Document Collection (UG643)*.

Linux Software Stack

Note: The Arm AArch64 architecture is common between the Zynq UltraScale+ MPSoC APU and the Versal ACAP APU. The existing architectural reference nomenclature "ZynqMP" found the Linux source also applies to Versal devices.

The Linux OS supports the Versal device. Xilinx provides open source drivers for all peripherals in the PS, and key peripherals in the PL. The following figure illustrates the full software stack in the APU, including Linux and an optional hypervisor.

Figure 10: Linux Software Development Stack

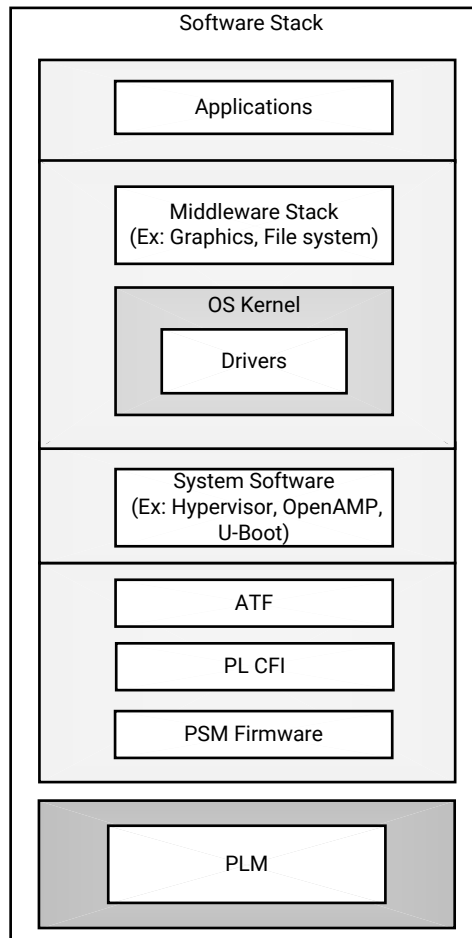

X23439-051321

Xilinx offers two tools to build and deploy custom Linux distributions for Versal devices: PetaLinux tools and the open source collaboration project, Yocto project. For more information, refer to <https://xilinx-wiki.atlassian.net/wiki/spaces/A/pages/18841996/Linux> on the Xilinx Wiki.

- PetaLinux tools:** The PetaLinux tools offer a simplified commands set to quickly build embedded Linux. The tools include a branch of the Linux source tree, U-Boot as well as Yocto-based tools to make it easy to build complete Linux images, including the kernel, the root file system, device tree, and applications for Xilinx devices. The PetaLinux tools work with the all the same open source Linux components described immediately below. More information about using PetaLinux to build custom distributions can be found on the [PetaLinux Tools](#) page and <https://xilinx-wiki.atlassian.net/wiki/spaces/A/pages/18842475/PetaLinux+Yocto+Tips> on the Xilinx Wiki.

- **Yocto Project:** The Yocto Project can be used by more experienced users to highly customize embedded Linux for their boards. For those interested in the Yocto Project, the Xilinx Wiki has several articles and information pertaining Yocto for building Linux on Xilinx devices. The <https://xilinx-wiki.atlassian.net/wiki/spaces/A/pages/18841883/Yocto> on the Xilinx Wiki is a great place to start. Yocto board support packages are also available from the main Yocto tree.

You can leverage the Linux software stack for the Versal device in multiple ways.

- **Open Source Linux and U-Boot:** Xilinx offers release-specific prebuilt images for the Versal ACAP kits, VMK180 and VCK190 that can be found on the [Versal ACAP Boards, Kits, and Modules page](#). The Linux Kernel sources including drivers, board configurations, and U-Boot updates for Versal devices are available from the <https://github.com/Xilinx/linux-xlnx/>, as well as, from the main Linux kernel and U-Boot repositories. For more information, refer to <https://xilinx-wiki.atlassian.net/wiki/spaces/A/pages/115048462/Release+Notes+for+Open+Source+Components> on the Xilinx Wiki.
- **Commercial Linux Distributions:** Along with open source Linux offerings, Xilinx works with several third-parties to offer other Linux solutions. Some commercial distributions also include support for the Versal devices, and they include advanced tools for Linux configuration, optimization, and debug. For more information, refer to the [Embedded Software & Ecosystem page](#).

FreeRTOS Software Stack

In a simpler RTOS, the RTOS itself is like a library that is linked together with the application and RTOS running in the same domain. In a more advanced RTOS, an optional process mode (e.g., VxWorks real-time processes, Nucleus Process Model, and QNX processes) is available with the same decoupling of applications and kernels as Linux. Xilinx provides a FreeRTOS BSP as a part of the Vitis software platform. The FreeRTOS BSP provides you a simple, multi-threading environment with basic features such as, standard input/output and access to processor hardware features. The BSP and the included libraries are highly configurable to provide you the necessary functionality with the least overhead. The FreeRTOS software stack is similar to the bare-metal software stack, except that it contains the FreeRTOS library. Xilinx device drivers included with the standalone libraries can typically be used within FreeRTOS provided that only a single thread requires access to the device.

★ **IMPORTANT!** *Xilinx bare-metal drivers are not aware of OS. They do not provide any support for mutexes to protect critical sections, and they do not provide any mechanism for semaphores for use during synchronization. While using the driver API with FreeRTOS kernel, you must take care of this aspect.*

The following figure illustrates the FreeRTOS software stack for the RPU.

Figure 11: FreeRTOS Software Stack

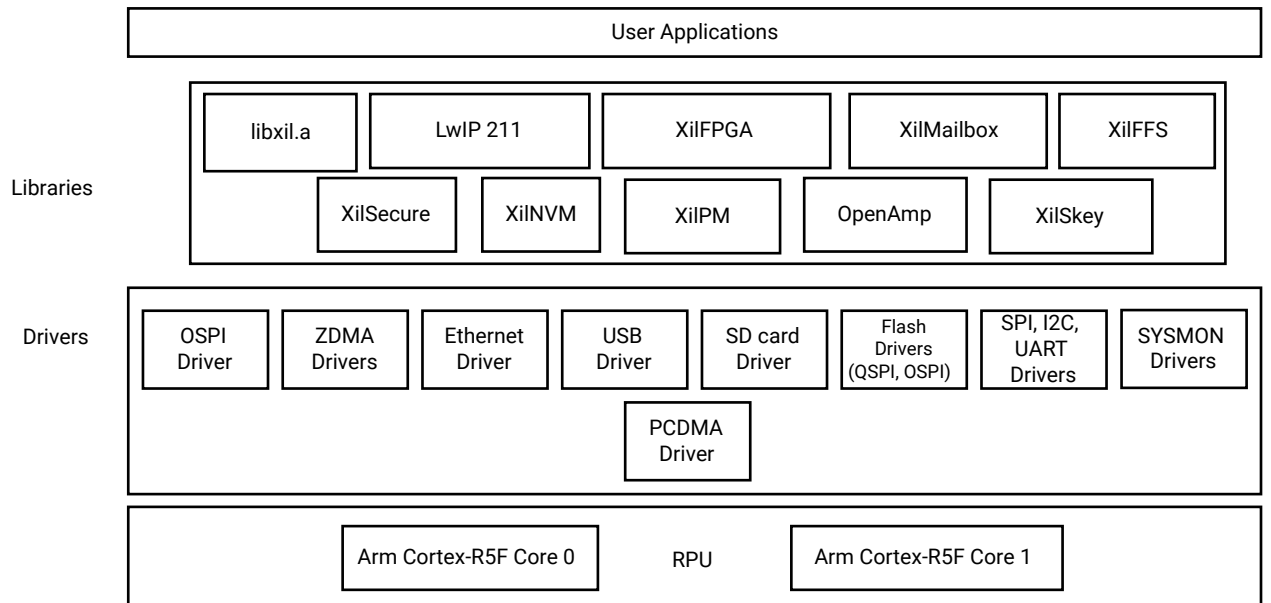

X16911-061521

Note: The FreeRTOS software stack for the APU is same as that for the RPU except that the libraries support both 32-bit and 64-bit operation on the APU.

Third-Party Software Stack

Many other embedded software solutions are also available from the Xilinx partner ecosystem. For more information, refer to:

- [Embedded Software & Ecosystem](#) page
- [Xilinx Third Party-Tools](#) page
- <https://xilinx-wiki.atlassian.net/wiki/spaces/A/pages/18842463/3rd+Party+Operating+Systems> on the Xilinx Wiki

Software Development Flow

This chapter explains the bare-metal software development for the RPU and APU using the Vitis™ IDE as well as Linux software development for the APU using PetaLinux tools.

The following figure shows the basic software development flow.

Figure 12: Software Development Flow

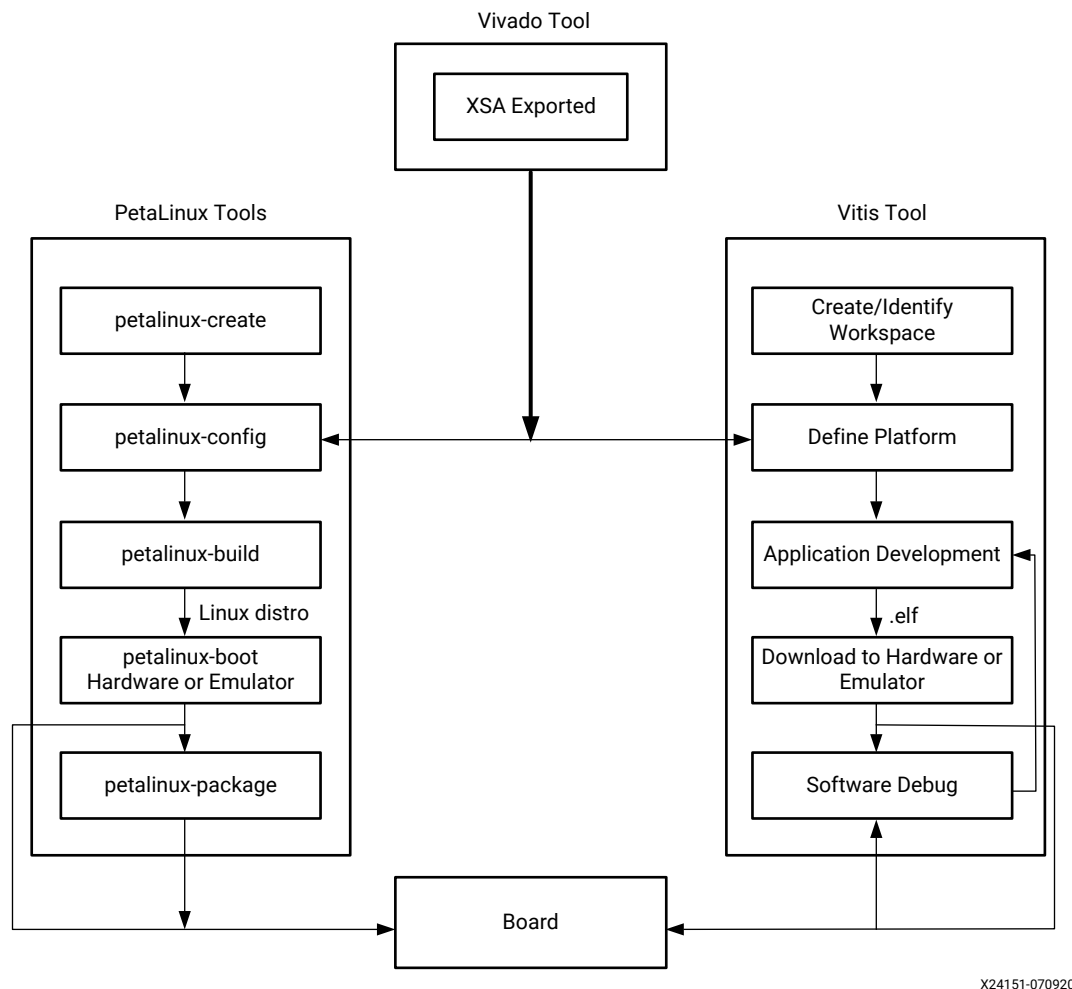

For more information, refer to [Vitis Embedded Software Development Flow Documentation](#) in the *Vitis Unified Software Platform Documentation (UG1416)*

Bare-Metal Application Development in the Vitis Environment

The following figure shows the bare-metal application development flow.

Figure 13: Bare-Metal Application Development Flow

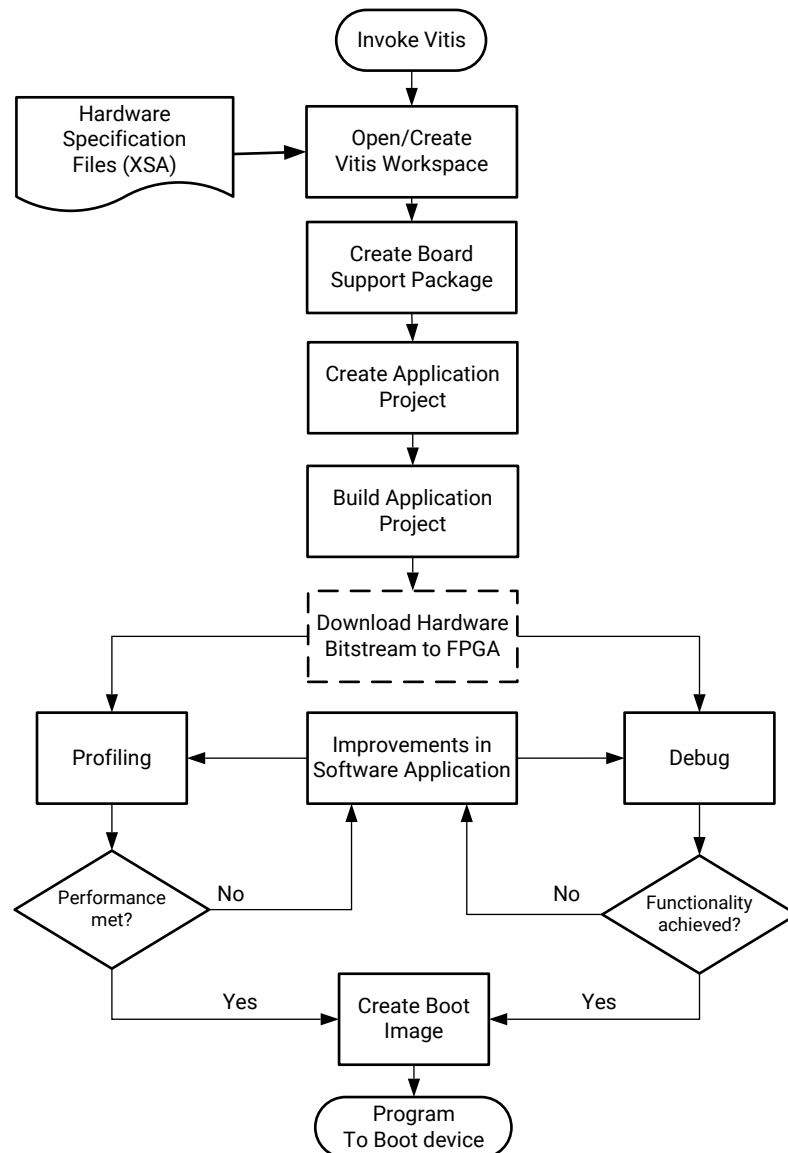

X14817-112420

Linux Application Development Using PetaLinux Tools

The software development flow in the PetaLinux tools environment involves many stages. The following figure shows the primary stages within the PetaLinux tools application development flow.

Figure 14: High-Level PetaLinux Tool-Based Software Development Flow

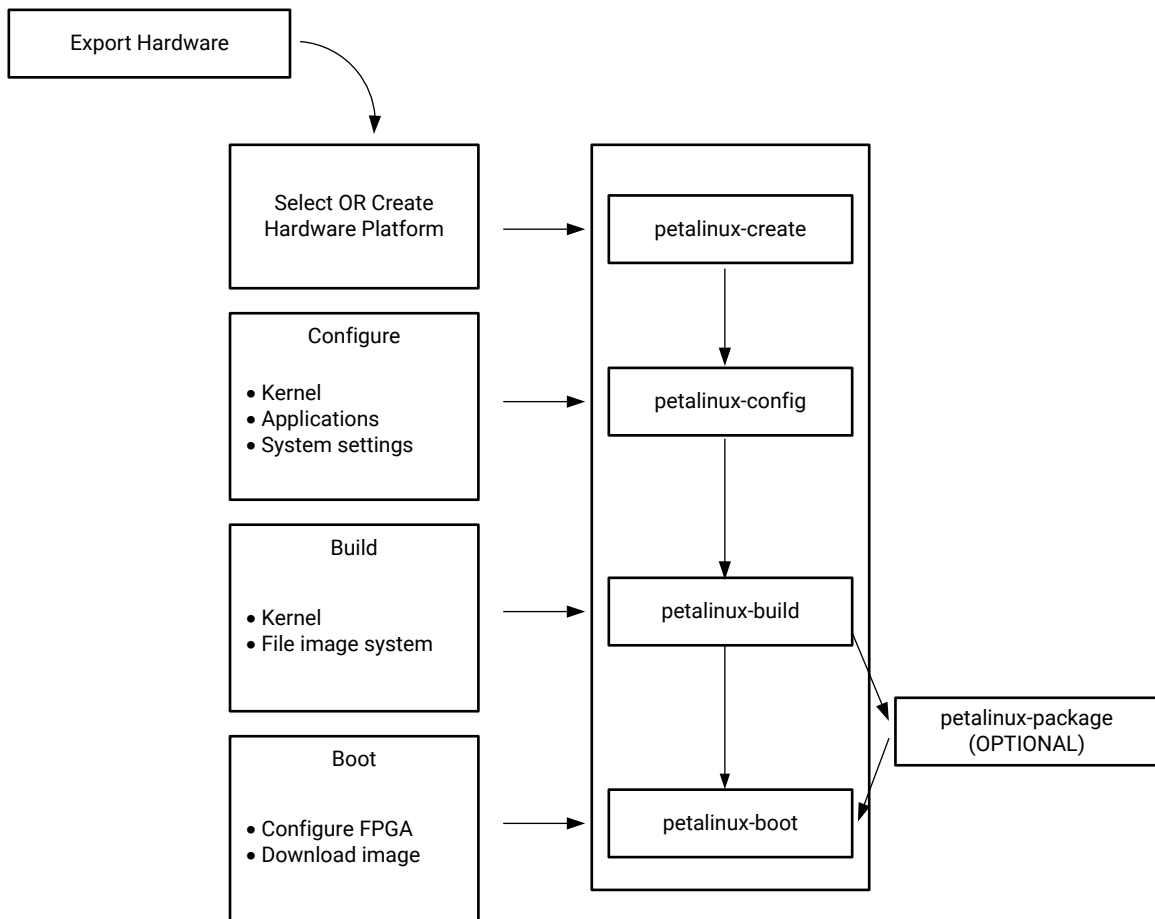

X24150-062420

The "Create Linux Images Using the PetaLinux" section in the *Xilinx Embedded Design Tutorials: Versal Adaptive Compute Acceleration Platform (UG1305)* shows you how to configure and build the Linux OS platform for Arm® Cortex®-A72 core-based APU on a Versal device, using the PetaLinux tools, along with the board-specific BSP.

For more information, refer to the Creating A New Project, Configure and Build the Project, and Boot and Packing the Project sections in *PetaLinux Tools Documentation: Reference Guide (UG1144)*.

Linux Application Development Using the Vitis Software Platform

The Vitis integrated design environment (IDE) facilitates the development of Linux user applications. This section provides an overview of the Linux application development flow from the Vitis tool.

The following figure illustrates the typical steps involved to develop Linux user applications using the Vitis platform.

Note: These steps work only when the Vitis platform is built with the Linux domain being available.

Figure 15: Develop Linux User Applications

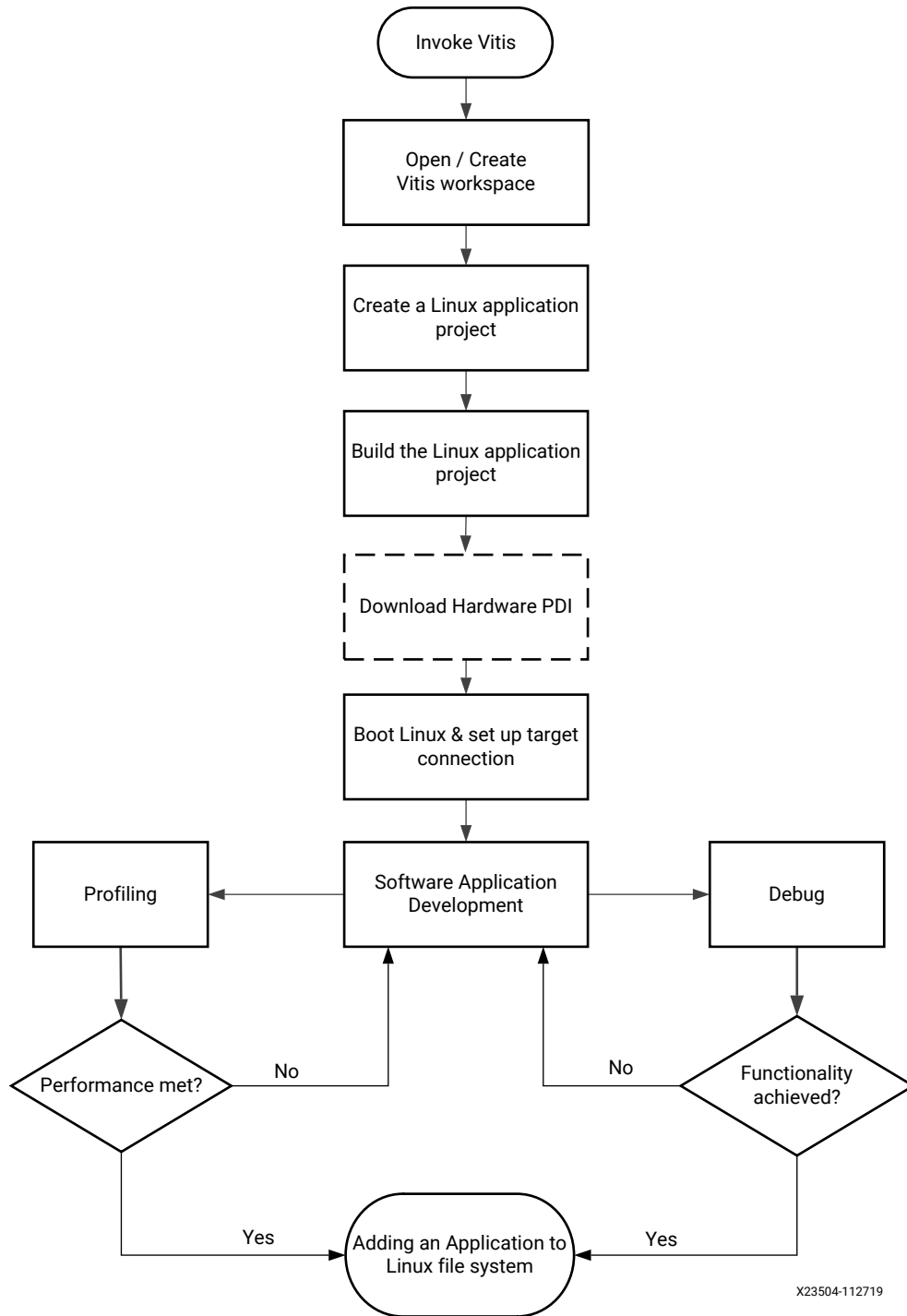

To complete the Linux application development flow from the Vitis tool which includes creating a software application, creating and building a sample project application, and debugging the application, see the *Xilinx Embedded Design Tutorials: Versal Adaptive Compute Acceleration Platform* ([UG1305](#)).

- For additional information on the Linux kernel and boot sequence, see [Chapter 3: Development Tools](#).
- For more information, refer to *Creating and Adding Custom Modules in PetaLinux Tools Documentation: Reference Guide* ([UG1144](#))

Software Design Paradigms

The Versal™ device architecture supports heterogeneous multiprocessor engines targeted at different tasks. The main approaches for developing software to target these processors are by using the following:

- **Frameworks for Multiprocessor Development:** Describes the frameworks available for development on the Versal device.
- **Symmetric Multiprocessing:** Using SMP with PetaLinux is the most simple flow for developing an SMP design with a Linux operating system for the Versal device.
- **Asymmetric Multiprocessing :** AMP is a powerful mode to use multiple processor engines with precise control over what runs on each processor. Unlike SMP, there are many different ways to use AMP. This section describes two ways of using AMP with varying levels of complexity.

Frameworks for Multiprocessor Development

Xilinx® provides multiple frameworks to facilitate application development on Versal ACAP as follows:

- **Hypervisor Framework:** Xilinx supports the Xen hypervisor, a critical item needed to support virtualization on the Versal ACAP. For details, refer to [Use of Hypervisors](#).
- **Security Framework:** The Versal device supports authentication, encryption, and other cryptographic features as a part of the security framework. To understand more about the security framework, see the [Chapter 9: Security](#) chapter.
- **TrustZone Framework:** TrustZone technology allows and maintains isolation between secure and non-secure hardware and software within the same system.

Xilinx provides TrustZone support through the Arm® trusted firmware (ATF) to maintain isolation between secure and non-secure worlds. If implementing a trusted execution environment (TEE) on a Versal device, ATF is one of the major components of a TEE. See [this whitepaper](#) for an overview of a TEE architecture.

- **Multiprocessor Communication Framework:** Xilinx provides the OpenAMP framework for the Versal device to allow communication between the different processing units.

- **Power Management Framework:** The power management framework allows software components running across different processing units to communicate with the power management unit.

Symmetric Multiprocessing

SMP enables the use of multiple processors through a single operating system instance. The operating system handles most of the complexity of managing multiple processors, caches, peripheral interrupts, and load balancing.

The APU in the Versal devices contains two homogeneous cache coherent Arm Cortex®-A72 processors that support SMP mode of operation using an OS, such as Linux or VxWorks®. Xilinx and its partners provide numerous operating systems that make it easy to leverage SMP in the APU. The following figure shows an example of Linux SMP with multiple applications running on a single OS.

Figure 16: Example SMP Using Linux

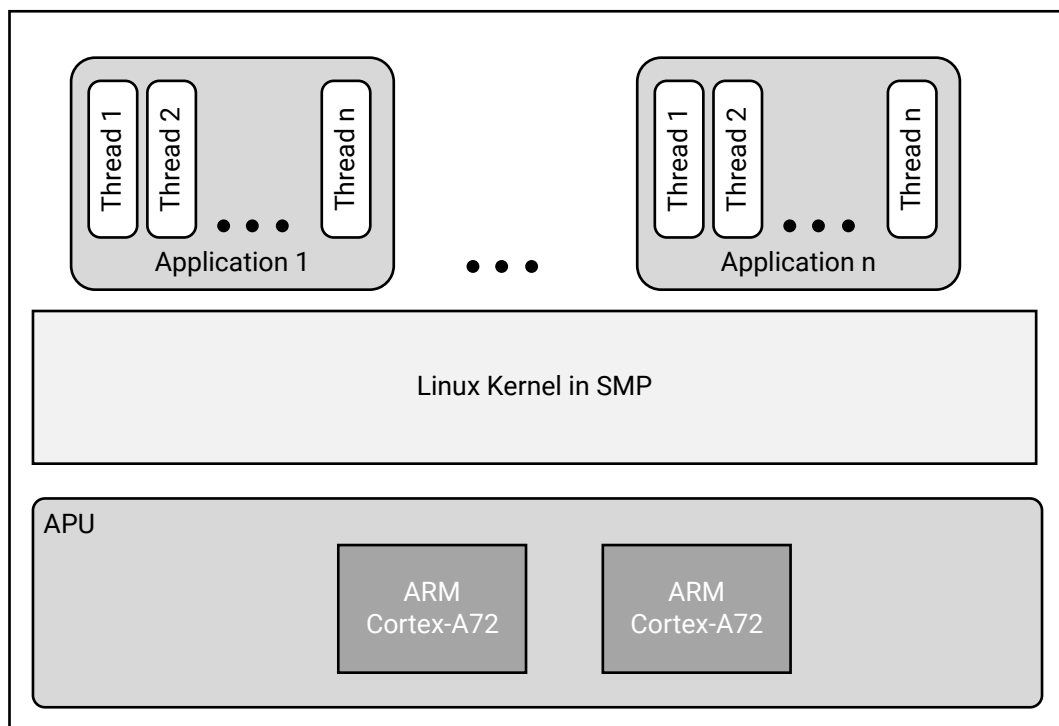

X23442-112719

This might not be the best mode of operation when there are hard, real-time requirements because it ignores Linux application core affinity, which must be available to developers with the existing Xilinx software.

Execution Domain and Images

A domain is a separate execution environment with its own address space and potentially attached devices. On a simple CPU, such as a minimal MicroBlaze processor without a memory management unit (MMU), there is only one domain. On more advanced CPUs, such as the APU, there are multiple domains, isolated by exception levels 0-3 (EL0-3) and some of those can have a segmented secure domain (SELO-1) as shown in the following figure.

Figure 17: Segmented Secure Domains on the APU

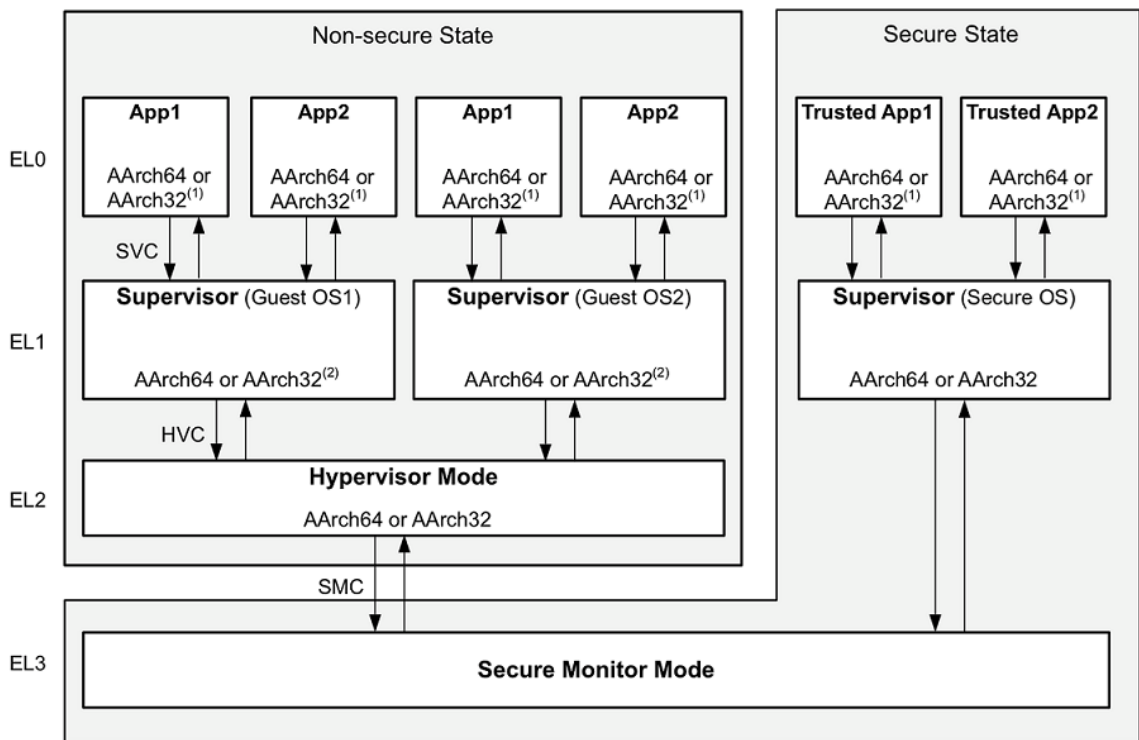

The following table shows examples of what can run in the various domains on an APU.

Table 4: Domain Examples

Domain	Non-Secure	Secure (TrustZone)
EL0	Linux process/application RTOS application process model	Secure or trusted application
EL1	Linux kernel RTOS kernel	Secure OS such as OP-TEE
EL2	Optional hypervisor (Xen), U-Boot	Not supported
EL3	ATF	

For CPU-like execution engines (APUs, RPU, MicroBlaze processors, AI Engine, and etc.) an image is the compiled program that runs in a domain. Typically, the standard ELF format is used, but in some cases, it is converted to more compact formats such as a PDI.

The term, *image*, is also used for the “code/logic” running in the PL/FPGA. The PL image or bitstream is an overloaded term as it refers both to configuration information (e.g., initiating a device) as well as the customer code translated to PL fabric configuration.

The images are loaded into their domains in a few different ways:

- **During Boot:**
 - A PDI file in QSPI, SD, eMMC, SMAP, or OSPI
 - BootROM handles loading the PLM, while the PLM will handle loading the rest of images. Additionally, U-Boot will handle loading a hypervisor, if used, as well as an OS, such as Linux.
 - A JTAG debugger can place an image into memory.
- **During Run Time:**
 - An operating system can load an image from a filesystem (rootfs, remote filesystem, SD card, etc.):
 - Another process (fork/exec)
 - Another CPU (through OpenAMP)
 - A hypervisor can load another virtual machine (VM) and its associated set of software.
 - An advanced RTOS with access to a filesystem can load images.
 - The PLM can load an image dynamically during restart or at the request of a client.

Most of the time, an image is loaded into a domain and while the data in the image changes, the code does not change until the end of the lifecycle. There are exceptions to this, most notably when Linux dynamically loads a driver as a kernel module, when a DFX region is loaded into the PL, or when a firmware update occurs.

An application can have multiple images attached to it. These multi-image applications are used for example when a regular Linux process is using an accelerator that needs to be loaded at the same time.

Asymmetric Multiprocessing

AMP uses multiple processors with precise control over what runs on each processor. Unlike SMP, there are different ways to use AMP. This section describes two ways of using AMP with varying levels of complexity.

In AMP, a software developer must decide what code has to run on each processor before compiling and creating a boot image. This includes both the APU and RPU processor clusters. For example, using AMP with the Arm Cortex-R5F processors (SMP is not supported) in the RPU enables developers to meet highly demanding, hard real-time requirements.

You can develop applications independently and program those applications to communicate with each other using inter-processing communication (IPC) options.

You can also apply this AMP method to applications running on the MicroBlaze processors in PL or even in the APU. The following diagram shows an AMP example with applications running on the RPU and the PL without any communication to each other.

Figure 18: AMP Example Using Bare-metal Applications Running in the RPU and PL

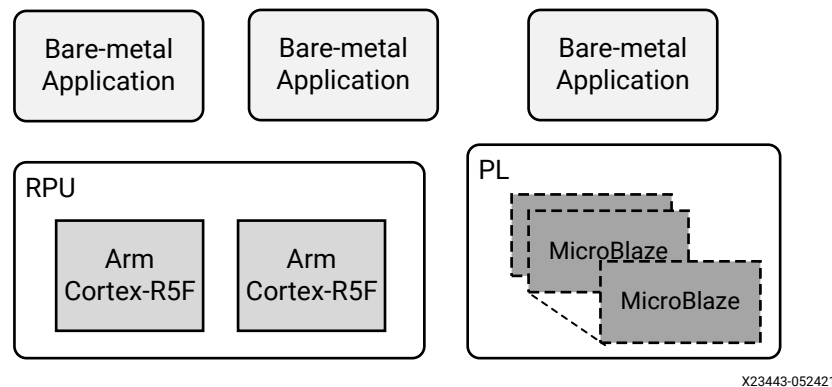

OpenAMP

Xilinx participates in OpenAMP, which is an open source project that provides support for APU and RPU communication. This communication path provides essential features that allow usage of the entire Versal ACAP. For example, using OpenAMP, the APU can load and unload the RPU software, and reset the RPU as needed.

The OpenAMP framework provides software components that enable development of software applications for AMP systems. The framework provides the following key capabilities:

- Provides lifecycle management and inter processor communication capabilities for management of remote compute resources and their associated software contexts.
- Provides a standalone library usable with RTOS and bare-metal software environments.
- Compatibility with upstream Linux remoteproc and RPMsg components

The OpenAMP supports the following configurations:

- Linux master/generic (bare-metal) remote
- Generic (bare-metal) master/Linux remote

- Generic (bare-metal) master/generic (bare-metal) remote

Proxy infrastructure and supplied demos showcase the ability of proxy on master to handle printf, scanf, open, close, read, and write calls from bare-metal based remote contexts.

For more advanced features, such as enhanced system management or higher level communications APIs, you might find helpful content within the OpenAMP community project, whose software targets Xilinx SoCs and others.

The OpenAMP framework provides mechanisms to do the following:

- Load and unload firmware
- Communicate between applications using a standard API

The following diagram shows an example of an OpenAMP architecture on a Versal device.

In this case, Linux applications running on the APU communicate with RPU through RPMsg protocol. Linux applications can load and unload applications on RPU with Remoteproc framework. This allows developers to load various dedicated algorithms to the RPU processing engines as needed with very deterministic performance. Notice that this architecture uses a mixture of SMP and AMP modes.

Figure 19: Example with SMP and AMP Using OpenAMP Framework

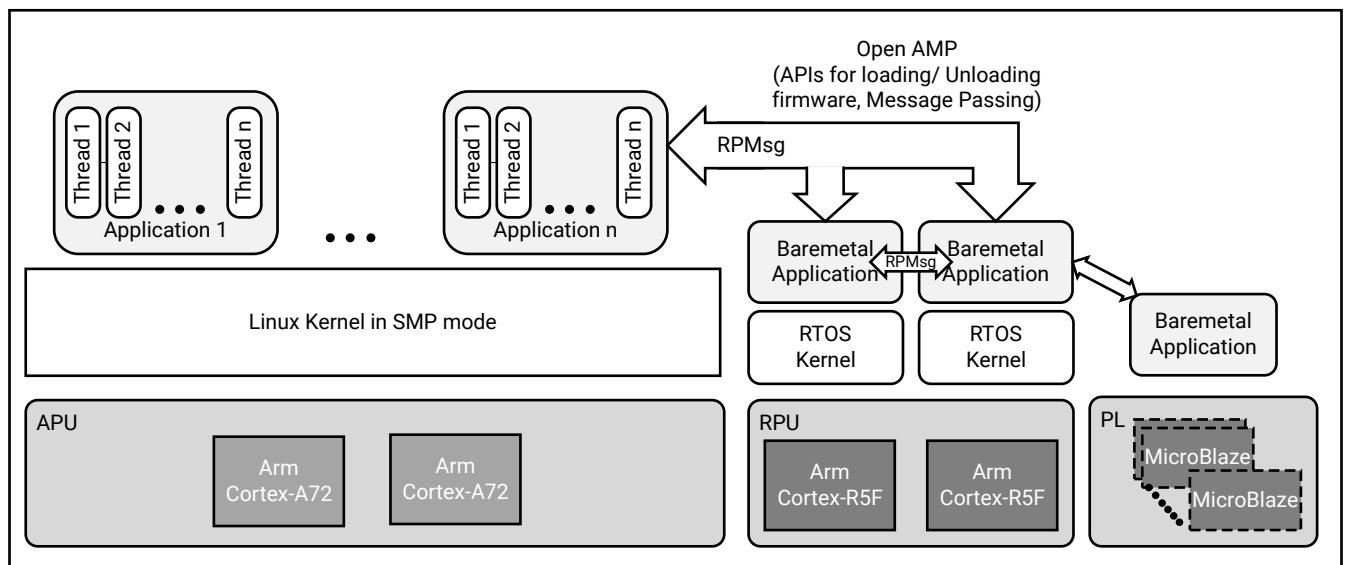

X23479-052421

For more information, see <https://xilinx-wiki.atlassian.net/wiki/spaces/A/pages/18841718/OpenAMP> on the Xilinx Wiki.

Virtualization with Hypervisor

Versal devices have hardware virtualization extensions on the Arm Cortex-A72 processors, Arm GIC-500 interrupt controller, and Arm System MMU (SMMU) that enables the use of hypervisors and enables greater hypervisor performance.

The following figure shows an example hypervisor architecture running on a Versal device. In this example, the hypervisor runs an SMP-capable OS, such as Linux, an RTOS, or a bare-metal application.

Figure 20: Example Hypervisor Architecture

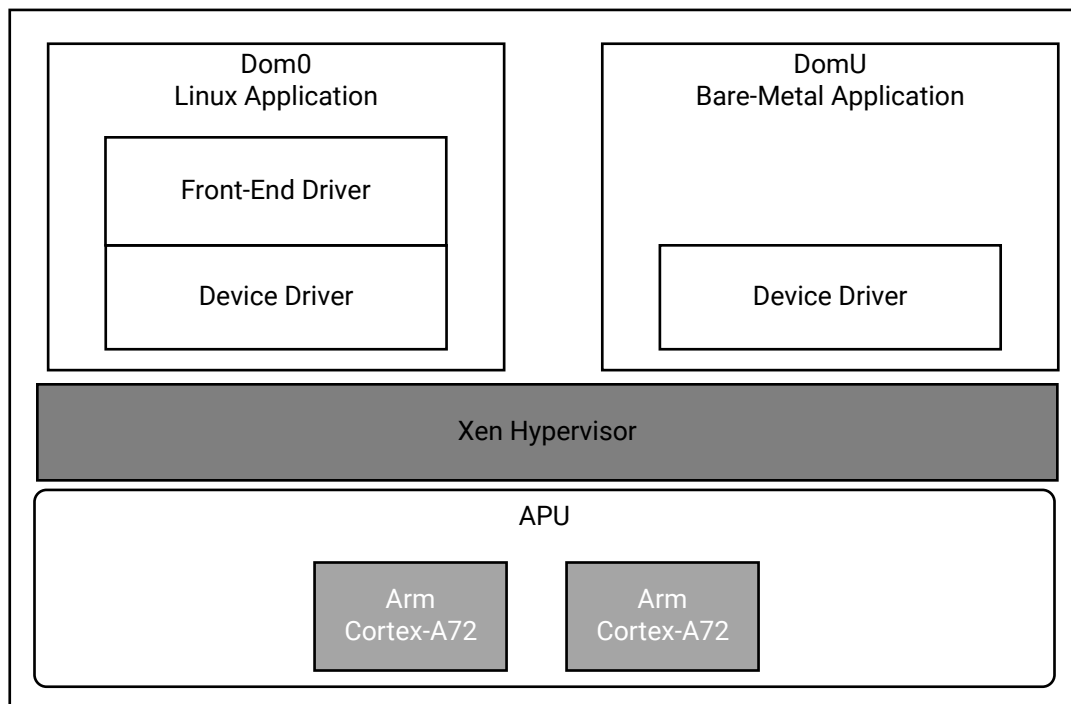

X23480-071020

The addition of a hypervisor introduces a layer of software that can add design complexity to low-level system functions, such as peripheral and accelerators access. Xilinx recommends that developers initiate efforts early into these aspects of system architecture and implementation.

Use of Hypervisors

Xilinx distributes a port for the Xen open source hypervisor for the Versal device. The Xen hypervisor provides the ability to run multiple operating systems on the same computing platform. Xen hypervisor, which runs directly on the hardware, is responsible for managing the CPU, memory, and interrupts. You can run multiple operating systems on the hypervisor, which are called domains, virtual machines (VMs), or a guest OS.

The Xen hypervisor provides the ability to concurrently run multiple operating systems and their standard applications with relative ease. It also makes it possible to give a guest OS direct access to specific peripherals. However, Xen does not provide a generic method to do so; peripheral-specific configurations are required.

The Xen hypervisor controls one domain, which is domain 0, and one or more guest domains. The control domain has special privileges including:

- Capability to access the hardware directly.
- Ability to handle access to the I/O functions of the system.
- Interaction with other virtual machines.
- Dynamic programming, such as adding a new FPGA block at run time in domain0 using device tree overlay.

The control domain also exposes a control interface to the outside world, through which the system is controlled. Each guest domain runs its own OS and application. Guest domains are completely isolated from the hardware.

Running multiple operating systems using Xen hypervisor involves setting up the host OS and adding one or more guest OS. For more information the Xen hypervisor, refer to <https://xilinx-wiki.atlassian.net/wiki/spaces/A/pages/18842530/XEN+Hypervisor> on the Xilinx Wiki.

Xen hypervisor is available as a selectable component within the PetaLinux tools; alternatively, you can download Xen hypervisor from Xilinx GIT. With Linux and Xen software that is made available by Xilinx, it is possible to build custom Linux guest configurations. Guest OS other than Linux require additional software and effort from third-parties. For more information, see the [PetaLinux Tools](#) page.

In addition to the Xen hypervisor, other hypervisors are available through various Xilinx ecosystem partners. Visit the [Embedded Software page](#) for further details.

Boot and Configuration

This chapter provides an overview of the boot and configuration process for Versal™ ACAP. This includes the boot device options, different stages of software involved in booting the platform and configuring different components.

The platform management controller (PMC) is responsible for boot and configuration and other post-boot tasks. A boot image, the programmable device image (PDI) is used to boot and configure Versal ACAP. A PDI contains platform loader and manager (PLM) executable, images, and configuration data. The PDI can be loaded from a boot device, such as an SD card, eMMC, OSPI, or QSPI, or it can be loaded through a slave interface, such as JTAG or SelectMAP. The BootROM starts the boot process and loads the PLM software that takes care of loading images and configuring the system based on images or configuration data in PDI.

Note: For hardware-related information, see the *Versal ACAP Technical Reference Manual* ([AM011](#)).

Versal ACAP Boot Process

The boot process is divided into four phases that are independent of the selected boot mode:

- **Phase 1:** Pre-Boot (Power-up and Reset)
- **Phase 2:** Boot Setup (Initialization and boot header processing)
- **Phase 3:** Load Platform (Boot image processing and configuration)
- **Phase 4:** Post-Boot (Platform management and monitoring services)

Note: Phase 1 and 2 are part of the BootROM stage.

The following sections provide a simplified overview the four phases.

Phase 1: Pre-Boot

Figure 21: Phase 1: Pre-Boot (Power-up and Reset)

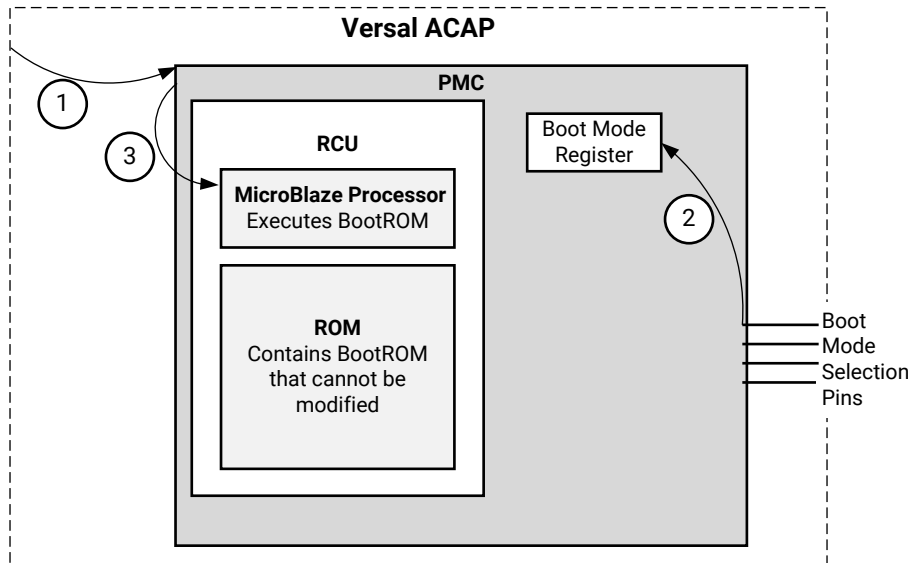

X22201-050119

- **1:** The pre-boot phase is initiated when the PMC senses the PMC power and the external `POR_B` pin is released.
- **2:** PMC reads the boot mode pins and stores the value in the boot mode register.
- **3:** PMC sends the reset signal to the RCU.

Note: All other processors and controller units remain in the reset state.

Phase 2: Boot Setup

Figure 22: Phase 2: Boot Setup

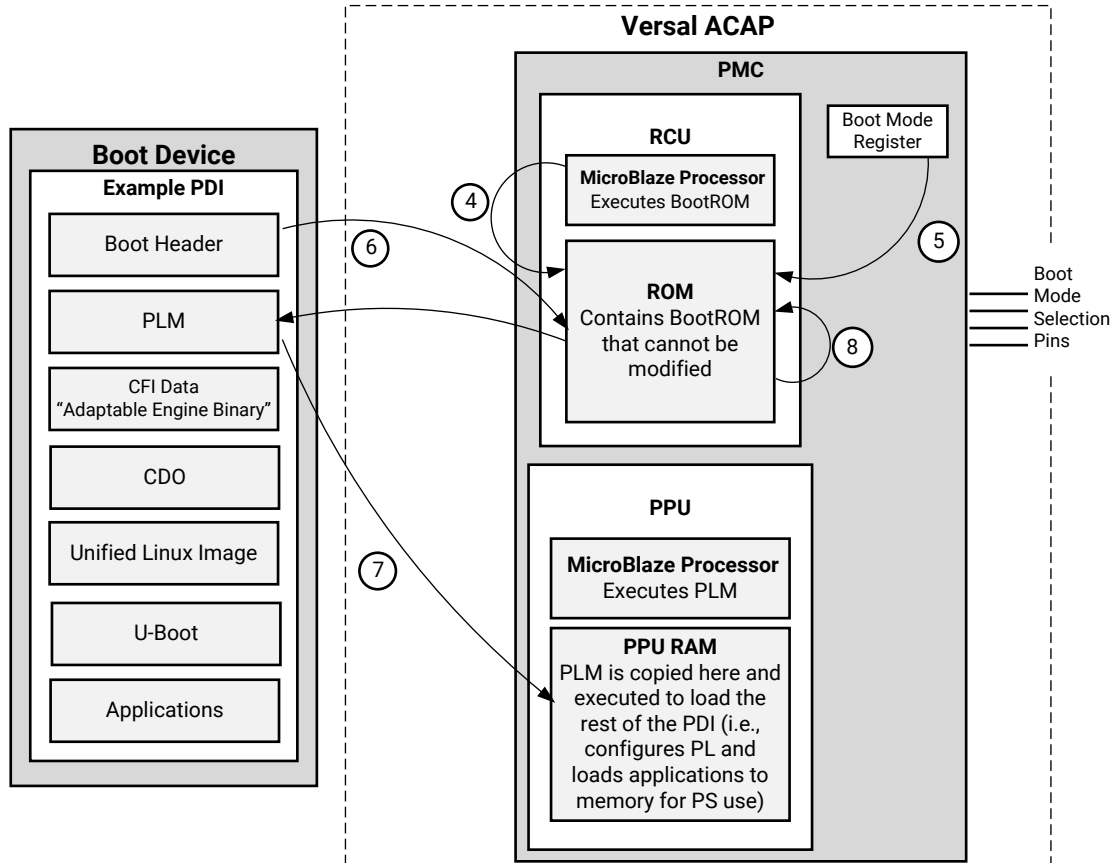

X22200-071020

- 4: The RCU begins to execute the BootROM from the RCU ROM.
- 5: The BootROM reads the boot mode register to select the boot device.
- 6: The BootROM reads the PDI boot header in the boot device and validates it.
 - If the boot header is valid, the BootROM configures boot parameters based on the boot header data and then continues the boot process.
 - If the boot header is not valid, then the normal boot process changes to the fallback boot process.
- 7: The BootROM releases the reset to the PPU, and loads the PLM from the PDI into the PPU RAM and validates it. After validation, the PPU is woken up (at this point, the PLM software starts executing, refer to point 9 in [Phase 3: Boot and Configuration sequence by PLM \(Platform Loader\)](#)).

- **8:** The BootROM executable enters a sleep state. The BootROM executable continues to run until the next power-on-rset (POR) or system reset, and is responsible for post-boot platform tasks.

Related Information

Phase 4: Post-Boot

Phase 3: Boot and Configuration sequence by PLM (Platform Loader)

Figure 23: Phase 3: Load Platform

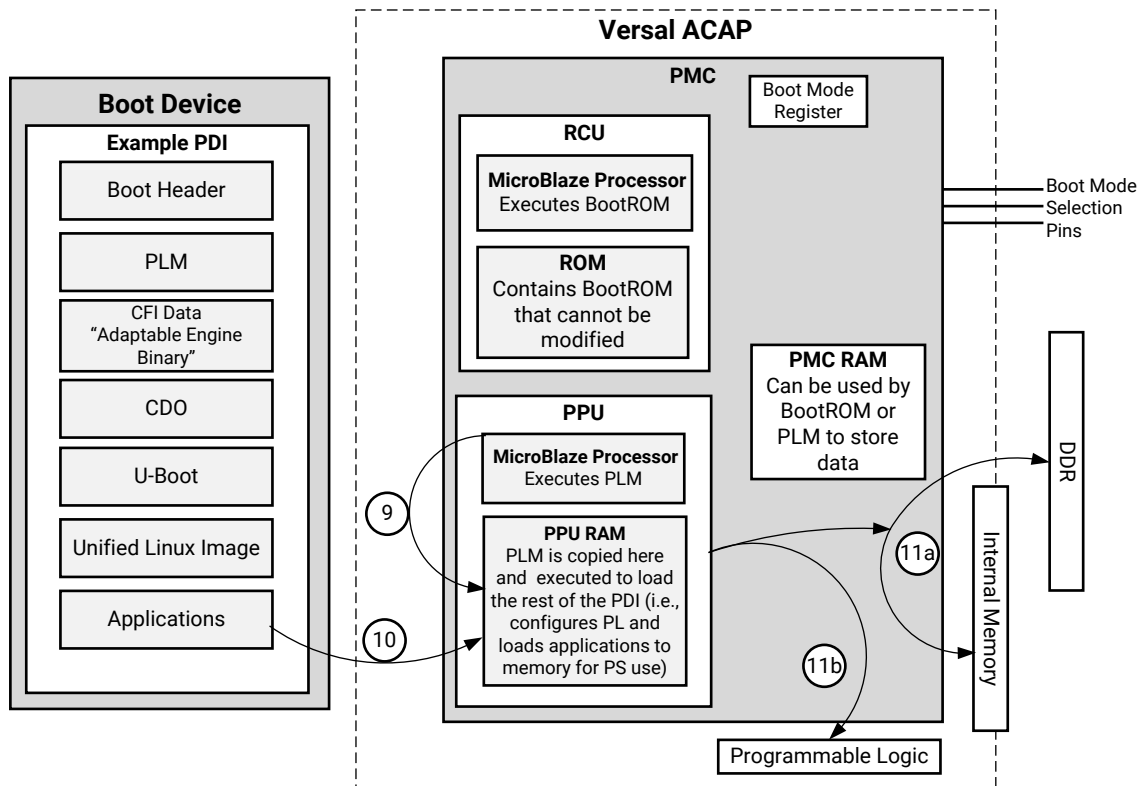

X22197-070620

- **9:** The PPU begins to execute the PLM from the PPU RAM.
- **10:** The PLM reads and processes the PDI components.
- **11:** The PLM configures other parts of the Versal device using the PDI contents.
 - **11a:** The PLM applies the configuration data to the following Versal ACAP components:

- PMC, PS blocks (CDO files)
 - Multiplexed I/Os (MIOs), clocks, resets, and etc.
- NoC initialization and NPI components (NPI file)
 - DDR memory controller, NoC, GT, XPIPE, I/Os, clocking, and other NPI components
 - Adaptable Engine (PL) data (CFI file)
 - AI Engine configuration (AI Engine CDO)

Note: The PMC triggers the scan clear of the individual programming control/status registers.
- **11b:** The PLM loads the applications and data for the Arm Cortex-A72 and Cortex-R5F processors to various memories specified by the ELF file. These memories include on-board DDR memory and internal memories, such as OCM and TCM.

Phase 4: Post-Boot

For a secondary boot device, the PLM performs the following tasks:

1. Determines the specified secondary boot device from a field in the PDI meta header.
2. Uses the specified secondary boot device to load the specified PDI image.

Figure 24: Phase 4: Post-Boot

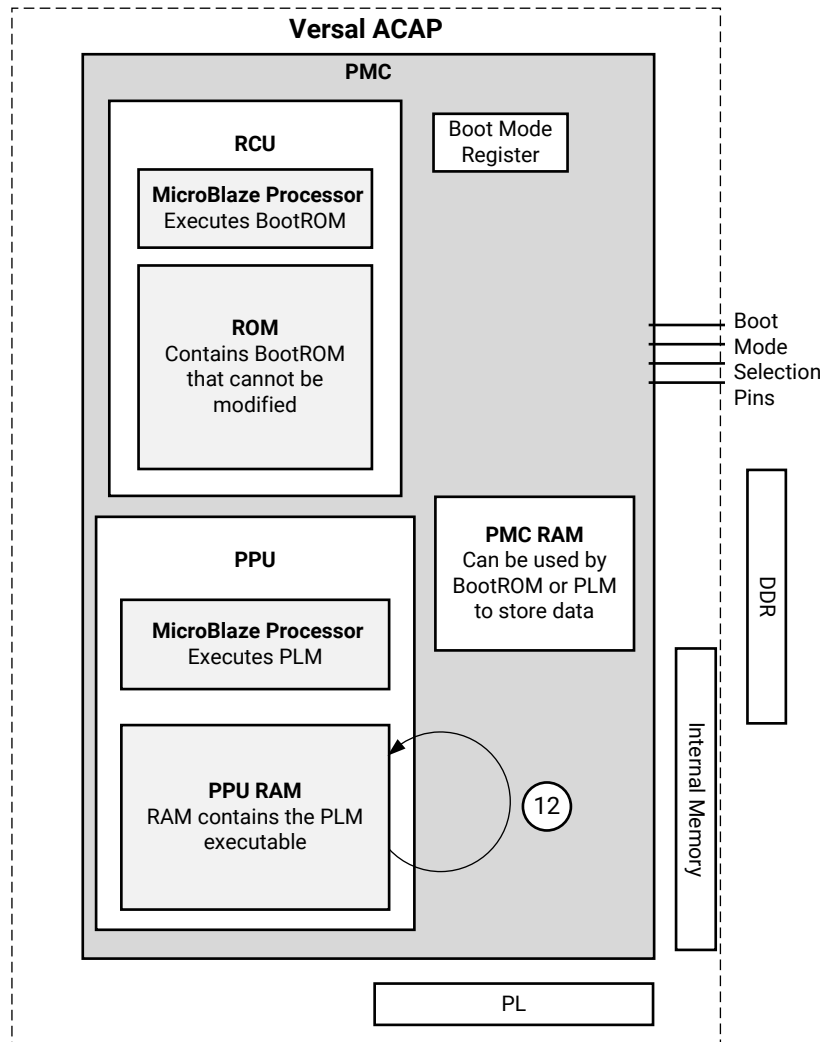

X22089-071020

- **12:** The PLM continues to run until the next POR or system reset, and is responsible for post-boot platform management tasks. Post-boot services include DFX reconfiguration, power management, subsystem restart, error management, and safety and security services.

Boot Flow

For system start-up, Versal ACAP must successfully initialize, boot, and configure from a supported boot source. There are two boot flows in the Versal ACAP architecture: secure and non-secure.

The following section describes the example boot sequences in which you can bring up various processors and execute the required boot tasks.

Non-Secure Boot Flow

The following figure illustrates an example boot and configuration sequence and shows how the PLM loads the major partition components of the Versal ACAP software stack.

Figure 25: Example Standard Boot Flow Processing Engines and Memory Sources

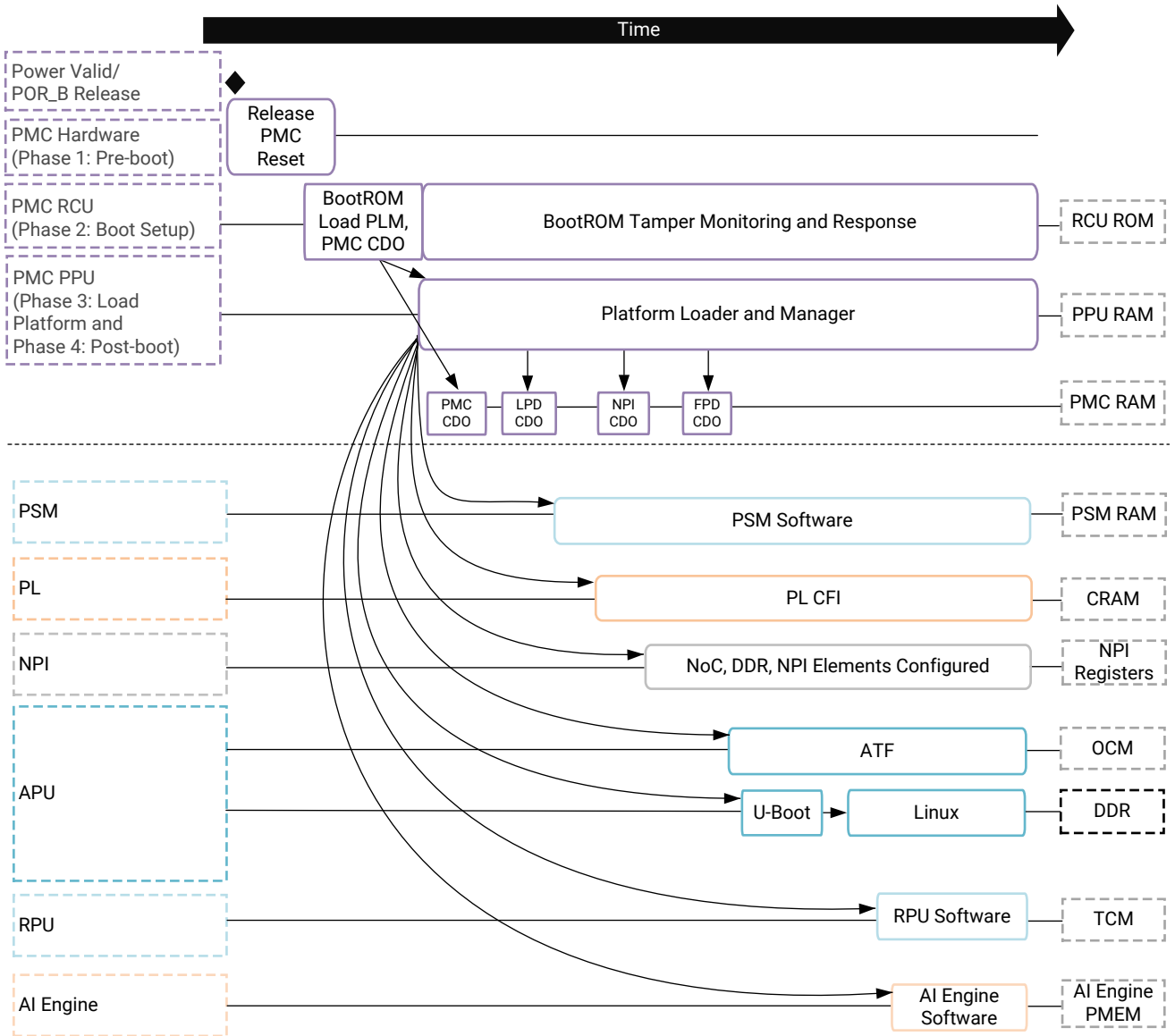

Note: All arrows indicate a loading and hand-off sequence except for U-Boot, which is handed off by the ATF.

Power Domains	Memory Source
PMC	Internal Memory
PL	External DDR
LPD	
FPD	
SPD	
BPD	

X23595-110820

In non-secure boot mode, the BootROM loads the PLM into the PPU RAM and releases the PPU to begin PLM execution. The PLM continues loading of the images from the PDI. In the above boot flow example, the PLM initializes LPD, FPD and DDR memory through CDO files. As a part of LPD image, PLM loads and starts PSM Firmware. PLM loads PL CFI through RCDO file. PLM loads ATF, U-Boot and starts ATF (EL3-S) on APU. ATF starts U-Boot (EL2-NS). U-Boot then loads Linux and hand-off to it. PLM can also load and start RPU and AI Engine images.

Note: In symmetric multi-processing (SMP) mode, the operating system manages the multiple Cortex-A72 processors.

Secure Boot Flow

For information on the secure boot flow, refer to:

- [Chapter 9: Security](#)
- [Versal ACAP Technical Reference Manual \(AM011\)](#)

PDI Content Integrity and Support for Secure Boot

The PDI content integrity is verified using checksums. Depending on the use case, executables and data objects in the PDI can be encrypted, authenticated, or both. For the artifacts to create the PDI, see [Boot Image \(PDI\) Creation](#).

Note: In the boot process description, the term *validates* includes checksum verification and authentication as needed.

Boot Device Modes

The following tables show the boot device choices for primary boot, and the boot device modes. For additional information, see the [Versal ACAP Technical Reference Manual \(AM011\)](#).

Table 5: Primary Boot Devices

Boot Mode	Mode[3.0] Pin Setting	Data Bus Width	Secure Boot	Fallback Boot and MultiBoot	Search Offset Limit
eMMC1 (4.51)	0110	x1, x4, x8	yes	yes	8191 FAT files
JTAG	0000	x1	no	no	N/A
Octal SPI single or dual-stacked ⁵	1000	x8	yes	yes	8 Gb
Quad SPI24 single or dual-stacked ⁵	0001	x1, x2, x4	yes	yes	128 Mb
Quad SPI24 dual-parallel	0001	x8	yes	yes	256 Mb

Table 5: Primary Boot Devices (cont'd)

Boot Mode	Mode[3.0] Pin Setting	Data Bus Width	Secure Boot	Fallback Boot and MultiBoot	Search Offset Limit
Quad SPI32 single or dual-stacked ⁵	0010	x1, x2, x4	yes	yes	4 Gb
Quad SPI32 dual-parallel	0010	x8	yes	yes	8 Gb
SD0 (3.0)	0011	x4	yes	yes	8191 FAT files
SD1 (2.0)	0101	x4	yes	yes	8191 FAT files
SD1 (3.0)	1110	x4	yes	yes	8191 FAT files
SelectMAP	1010	x8, x16, x32	yes	no	N/A

Notes:

1. Execute in place (XIP) is not supported by Versal ACAP.
2. The legacy mode Linear Quad SPI (LQSPI) is not supported by Versal ACAP.
3. The "search offset limit" is used when the BootROM executable is searching the boot device for a PDI with a boot header and a PLM. This is used for fallback boot and MultiBoot.
4. JTAG and SelectMAP are slave boot modes. All other devices in this list are master boot modes.
5. For dual-stacked QSPI, only the first flash device can be accessed during the bootROM stage.

When selecting a boot device to implement in a board design, it is important to consider the post-boot use of shared multiplexed I/O pins and the voltage requirements of each boot mode. For more information, refer to the *Platform Management Controller* chapter in the *Versal ACAP Technical Reference Manual* ([AM011](#)).

Secondary Boot Process and Device Choices

The boot process can also involve an optional secondary boot device. In this case, the boot process starts with a PLM and other initial images loaded from a primary boot device. The rest of the images are then loaded from a secondary boot device which is configured by a PLM. The secondary boot device contains a PDI that includes images and configuration data that needs to be loaded from the secondary boot device. This secondary boot device does not contain a PLM or a boot header. At POR/system reset, the boot process starts with the primary boot. This process is the same as in the primary boot process:

- **BootROM:**

- Reads boot mode register to determine the primary boot device
- Loads the PLM from the specified primary boot device into the PPU RAM
- Releases the PPU to execute the PLM

Note: The secondary boot process occurs if a secondary boot device is specified in a field in the PDI meta header.

- **PLM:**

- Determines the specified secondary boot device from a field in PDI meta header

- Uses the specified secondary boot device to load the remainder of the PDI content

Note: The secondary boot device cannot be the same as the primary boot device.

The secondary boot devices include:

- eMMC0, eMMC1

Note: There are two controllers (eMMC0 and eMMC1). Each controller allows two different sets of MIO to be assigned or an EMIO option. Primary boot on the first slot (eMMC0) is not supported. The second slot (eMMC1) cannot be used because it conflicts with the QSPI MIO pins. The first slot eMMC1 (MIO26-36) can be used for secondary boot.

- Ethernet

Note: When Ethernet is used as a secondary boot device, Versal ACAP is first booted up to U-Boot using the primary boot device. U-Boot can then use Ethernet to complete the boot process.

- OSPI

- PCIe® interface

1. First, the PLM is loaded from the primary boot device into the PPU RAM.
2. Then, the PLM runs and initializes the Cache Coherent Interconnect for Accelerators (CCIX) PCIe Gen4 Module (CPM) block in PCIe Endpoint (EP) mode.
3. Finally, the PCIe host, as a secondary boot device, loads the rest of the images.

Note: PCIe interface is supported only as secondary boot device.

- QSPI

- SD0, SD1

- USB

The secondary PDI is downloaded using dfu_util to a fixed DDR memory address (0x50000000). The dfu_util is an open source utility available for Windows and Linux. The PLM then processes the PDI.

To indicate USB as a secondary boot mode, specify usb as the boot_device attribute in the BIF file.

- SelectMAP (SMAP)

Use smap as the boot device attribute for SelectMAP as secondary boot mode in the BIF file.

Secondary Boot Combinations

- Any non-SD eMMC primary boot and SD/eMMC as secondary boot mode
- eMMC boot partition 1/2 as primary boot and eMMC user area as secondary boot
- eMMC boot partition 1, boot partition 2, and user area as primary boot modes

Boot Process for Primary Boot Device

The boot process can be based on a primary boot device such as SD, eMMC, QSPI, OSPI, or on a slave interface such as JTAG or SelectMAP. At POR or system reset, the boot process starts with the primary boot:

- BootROM
 - Reads the boot mode register to determine the primary boot device
 - Loads the PLM from the specified primary boot device into the PPU RAM
 - Releases the PPU to execute the PLM
- PLM: Loads remainder of PDI content (Images and partitions) from the primary boot device.

Fallback Boot and MultiBoot

Fallback boot allows the Versal ACAP to automatically boot a different PDI than the initial PDI on the same primary boot device, if the first PDI fails to boot. If an error occurs during the PDI boot sequence, the PLM increments the MultiBoot register by 1 and resets (SRST) the device so that the BootROM can find the next good image.

An error during boot PDI load can occur due to various reasons. Some examples for PLM errors include:

- PDI header fields are not valid
- Copy from boot device has failed.
- Unavailability of power while loading corresponding power domain CDOs (LPD, FPD, NPD, PL, etc.).
- Checksum or decryption or authentication failure while loading partitions, if enabled.
- Command failures (such as DDR memory calibration `mask_poll` command time out) during CDO processing.

Note: The PLM does not perform any reset (SRST) in the JTAG boot mode for any errors to enable debugging of the system.

MultiBoot allows the Versal ACAP to boot from a different boot PDI other than the initial PDI. You can specify the boot PDI to be used for booting in this case. The PLM provides a command for user applications to update the multiboot value during run-time. For more information, see the [XilLoader/IPI CDO Commands](#).

To use fallback boot or MultiBoot, store multiple PDIs in the same primary boot device within the search limit for the device. For information, see the Primary Boot Devices table in [Boot Device Modes](#).

Boot Mode Search Limits

The BootROM has a search limit to locate the device image boot header for every boot mode. The following table lists the boot image search limits for each mode.

Table 6: Boot Mode Search Limits

Boot Mode	Search Offset Limit
OSPI (single, dual-stacked)	8 Gb
QSPI24 (dual-parallel)	256 Mb
QSPI24 (single, dual-stacked)	128 Mb
QSPI32 (dual-parallel)	8 Gb
QSPI32 (single, dual-stacked)	4 Gb
SD0 (3.0), SD1 (2.0), SD1 (3.0), or eMMC1	8191 FAT files (default)
8191 FAT files (default)	eMMC device size

Note: When using OSPI or QSPI dual-stacked mode, the BootROM can only access the lower QSPI or OSPI addressable flash memory space for boot. After boot, the PLM can access the upper QSPI or OSPI for additional image storage

Octal-SPI and Quad-SPI Boot Devices

The BootROM executable supports fallback boot and MultiBoot on Octal-SPI and Quad-SPI boot devices. The BootROM searches QSPI and OSPI devices in 32k offsets, for example, if the multiboot register value is two, then it starts the image search from offset $0x10000 (2 * 32k)$.

SD/eMMC Boot Devices

The BootROM executable supports fallback boot and MultiBoot on SD card and eMMC flash devices. The SD card or eMMC flash must be partitioned so that the first partition is a FAT 16/32 file system. Bootgen is used to create PDI files with the names: `boot.bin`, `boot0001.bin`, `boot0002.bin`, etc.

Except for the `PMC_MULTI_BOOT` value '0,' the `PMC_MULTI_BOOT` value is concatenated with first the string `boot`, then `PMC_MULTI_BOOT`, then `.bin` to create the specified PDI file name. For example, if `PMC_MULTI_BOOT= 2`, then the PDI file name is `boot0002.bin`. For command line users, the PDI file names are specified on the Bootgen command line. The PDI files are then copied to the FAT16/32 file system on the boot device. The search limit specified for the device corresponds to the maximum number in the file name, for example `boot8190.bin`. Here, there are 8191 files starting with `boot.bin` and ending with `boot8190.bin`. Therefore, the search limit is 8190.

Figure 26: SD and eMMC FAT16/32 Files for Fallback Boot and MultiBoot

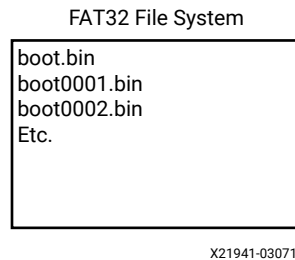

SD/eMMC RAW Boot Mode

A RAW partition is any partition on the eMMC that is not formatted. BootROM and PLM supports SD/eMMC in RAW format in addition to the existing file system mode support.

The BootROM searches for the boot image and finds it on the file system or in RAW. After the image is found, the BootROM updates the Multiboot register with the image information. The PLM continues the boot from the file system or RAW with the information from the MultiBoot register.

The MultiBoot register contains information such as whether the image is from the file system or RAW, image file number or the offset.

Programmable Device Image

The boot image for the Versal ACAP is called a PDI, which is a Xilinx file format processed by the PLM as part of the Versal ACAP boot process or partial configuration process. The PDI data is specific to the design requirements. The Versal ACAP boot image typically involves binaries used to boot and configure the platform, these binaries can include: bootloader, firmware, hardware configuration data, OS and user applications. Examples include adaptable engine (PL) configuration file, PLM image, ATF, U-Boot, Linux kernels, rootfs, device tree, and standalone or RTOS applications.

A PDI file is a collection of images, where an image consists of one or more partitions. A partition can include:

- CDO file consisting of a list of commands executed in sequence
- Loadable data (for example, APU/RPU ELF's or data)

There can be different PDI files based on the use case.

- **PDI for Versal ACAP Start-up:** Occurs during the power-on reset (POR) and SRST. This PDI contains the following information needed to boot, configure, and manage a Versal ACAP:
 - A boot header
 - A PLM subsystem
 - Additional subsystem images and image partitions which are used to configure a specific subsystem or engine. These can also include necessary CDO. Some of these images can also be part of another PDI that is targeted for secondary boot.
- **PDI for Subsystem Restart or DFX:** Occurs in some power management, warm restart, PL reconfiguration, and DFX scenarios.

This type of PDI contains the images or partitions needed to reconfigure parts or subsystems of the Versal ACAP, and does not contain the boot header, PLM, and the PMC.CDO.

Note: The RCU executes the BootROM that loads the PLM into the PPU RAM. The BootROM then releases the PPU from reset and executes the PLM.

Configuration Data Object

Configuration data object (CDO) files are intended to pass the configuration information generated from tools to the platform loader and manager (PLM). Non-secure and secure PDI load support from Linux is supported using the FPGA manager. During the PDI load sequence, the PLM passes information from CDOs (CDO commands) to various components to configure the system.

Configuration can be generated as multiple CDO files, and each CDO file is included as a partition in the programmable device image (PDI) file. The CDO is a list of commands and is meant to include pre-load or pre-boot requirements for any subsystem.

Adaptable Engine (PL) configuration data, which is generated as a raw file (CFI file), is passed as an input to Bootgen. Bootgen includes this configuration data as a partition in the PDI, and creates a PDI image.

Boot Image (PDI) Creation

The Xilinx boot image generation tool, Bootgen is essential in creating an image file (PDI) used to boot and configure Versal ACAP. Bootgen creates the boot image (PDI for Versal ACAP) by building the required boot header, appending tables that describe the images and partitions, and processing the input data files (ELF files, PL configuration data, and other binary files) to partitions. Bootgen has specific features to assign specific destination memory addresses or imposing alignment requirements for each partition. Bootgen also supports the encryption, authentication, and calculation of checksums on each partition.

An input file (*.bif) known as the boot image format (BIF) file serves as the input for Bootgen.

For detailed information on building a boot image, see the *Bootgen User Guide* ([UG1283](#)).

For Versal ACAP, the Vivado tool flow generates a PDI using Bootgen in the backend. This PDI contains hardware-specific user configuration data, Adaptable Configuration data, NPI Data, and a PLM. Typically, the PDI is outputted from the Vivado tools and then exported to software tools, such as the Vitis software platform or PetaLinux. These tools either reuse the PDI components or input the PDI, additional software executables, or images to create a larger PDI. The Vitis tool PDI contains a PLM (optionally modified), the configuration data generated by Vivado tools, and typically contain applications that run on the APU and/or RPU cores.

Bootgen is essential in creating an image file (PDI) to boot and reconfigure Versal ACAP. Bootgen places all of these binary images and generates a bootable image in a specific format that the PLM can interpret while loading the image.

The PDI created in the Vivado tool will contain the following images or configuration data:

- Boot header (part of PDI, based on BIF attributes)
- PLM (platform-independent)
- PMC CDO
- Meta headers
- LPD CDO (based on CIPS configuration)
- PSM (subject to CIPS configuration)
- CFI data
- NPI data
- FPD CDO (based on CIPS configuration)

Some data files or images, like LPD/FPD CDO, and PSM might not be required for PL only flow, and may not be created for some use-cases like PL only, which involves limited CIPS configuration for PMC and I/O.

Extending the PDI generated by the Vivado Design Suite

Example files from the Vitis tool that can be input to Bootgen:

- PLM

Note: Bootgen supports the replacement of the PLM and PSM ELF files from the Vivado-generated PDI. This is only if these need to be modified for specific needs. Most use cases should work with the default PLM and PSM ELFs from the Vivado tool. The [PLM Boot and Configuration](#) section discusses the files used by each subsystem and lists the general requirements for loading that subsystem.

- Arm Cortex-A72/Cortex-R5F applications
- AI Engine configuration (DMAs, etc.)
- AI Engine ELFs
- U-Boot

Bootgen uses the following types of input to create the PDI:

- PDI generated from the Vivado tools.
- Other files from the Vitis tools, which includes an optionally modified PLM. The custom PLM replaces the default PLM. However, for most cases the default PLM can be used as is.
- Optionally, a user-created boot image format (BIF) file, which provides Bootgen with the instructions needed to create a Vitis tool PDI. If required (in few rare use-cases), Vivado generated BIF can be reused to create/update an updated PDI in case some Vivado-generated file is updated.

Software Developer Control of PDI File Creation via BIF File

A Xilinx boot image format (BIF) file is used to specify the subsystem images in the PDI and the subsystem image partitions. Each separate file within a subsystem image is stored in one of the subsystem image partitions. The BIF file is a data file in ASCII format. The BIF file tells Bootgen how to create the PDI by processing each of the input files.

Note: The PLM is processed by the BootROM, so it is not formatted as a subsystem image or partition.

If required, you can modify the Vivado-generated BIF and run Bootgen using the command line flow to create an updated PDI. You can optionally write your own BIF file and specify the Vivado generated PDI along with other input files to extend the PDI. In the Vitis IDE, you can use a wizard to specify the required inputs for the BIF file, and then use the Vitis IDE to create the BIF file and run Bootgen to create the PDI.

Note: The Bootgen wizard is not fully implemented for Versal ACAPs. Currently, the wizard only supports PS and AI Engine partitions without any security features such as encryption, authentication, etc.

Methods for Copying the PDI to a Primary Boot Device

For system configurations that use a master boot mode, the PDI file must be copied to the boot device. The following methods can be used to copy the PDI file to the master boot mode device:

- Vivado tool hardware device manager
- Vitis tool program flash utility
- Removable devices, such as an SD card, can be programmed separately, and then added to the board.
- Socketed and soldered devices, such as QSPI, can be off-board programmed, and then put onto the board.

Note: When the PDI is copied to the boot device via the Vivado tools hardware device manager or the Vitis tool program flash utility, a cable is connected from the host PC to the PMC JTAG port, and the master boot device is programmed via the JTAG interface. JTAG can also be used to boot Versal ACAP to U-Boot, and then U-Boot can be used to program the master boot device.

Platform Loader and Manager

The platform loader and manager (PLM) runs on the platform processing unit (PPU) in the platform management controller (PMC). It performs boot and configuration of the Versal device, and then continuously provides services after the initial boot and configuration.

During the initial boot, the BootROM decodes the programmable device image (PDI) and loads the PLM into the PPU RAM. The PPU PLM processes the PDI to boot up the entire system by loading the partitions present in the PDI. The PLM supports the loading of partial PDIs during run time. See *Versal ACAP Technical Reference Manual* ([AM011](#)) for more information.

PLM Boot and Configuration

BootROM, PLM Handoff State

The BootROM loads the PLM into the PPU RAM from the boot device and is responsible for releasing the PPU from reset to start the PLM execution..

The PLM ELF is loaded to the PPU RAM. The PMC RAM is used to load the PMC DATA CDO file.

The state of the system at BootROM handoff is as follows:

- The PPU is sleeping with the reset released, in case of normal JTAG boot mode (when PDI is not loaded in JTAG mode. This is the Zynq UltraScale+ MPSoC equivalent).
- The PPU RAM and PMC RAM are initialized with error code correction (ECC).
- The JTAG IDCODE instruction is always available regardless of the boot mode. Except the JTAG IDCODE instruction, all other JTAG instructions can be disabled when you program the required eFUSES. If the eFUSES are not programmed and a secure boot occurs, then only the base JTAG instructions are supported. When the AUTH_JTAG enable instruction is sent to the Versal ACAP in a secure boot mode, the full set of JTAG instructions (base +extended) can be enabled.
- The boot device is taken out of reset and initialized.

PLM Subsystem

PLM and PMC CDO together constitute the PLM subsystem. PMC CDO contains the details of the device topology, subsystem details, and PMC configuration data.

Table 7: Components of the PLM Subsystem

File	Contents
PLM ELF	PLM ELF File
PMC CDO	PMC CDO file <ul style="list-style-type: none"> • Device topology subsystem details • PMC Configuration: Register writes/polls for MIO, clocks, resets

The BootROM loads the PLM ELF and PMC CDO files to the PPU RAM and PMC RAM, respectively.

After the BootROM handoff to the PLM, the PLM performs the following tasks:

- Initializes the PPU and register interrupts.
- Initializes the modules to register the CDO/IPI commands and handlers.
- Configures the PMC CDO file.
 - Device topology with PMC CDO commands to registers the nodes.
 - General/platform management calls to initialize the PMC and LPD MIO, clocks, etc.
 - PMC initialization for clocks, MIOs, resets.

LPD Configuration

LPD configuration contains configuration data that is required to initialize the LPD peripherals and clocks.

Table 8: LPD Configuration

File	Contents
LPD CDO	<ul style="list-style-type: none"> • PS LPD PM init node commands (SC, LBIST, BISR, MBIST) • LPD configuration: Register writes/polls
PSM ELF	PSM ELF file

After initializing the PMC CDO:

- The PLM re-initializes the boot device and loads the LPD CDO file from the boot device.
 - Configures the LPD CDO file.
 - Initiates the Scan Clear, BISRs, MBIST as required for LPD.

- XilPM releases resets and powers up the nodes based on the CDO requirements.
- The PLM loads the PSM ELF file and waits until initialization is complete.

Before loading the LPD configuration, ensure that PMC.CDO is configured.

PL Configuration

In Versal ACAP, the Adaptable Engine (PL) consists of CDO and NPI files. CDO mainly contains Cframe data along with PL and NoC power domain initialization commands. NPI contains configuration data related to the NPI blocks. NPI blocks include NoC elements (NMU, NSU, NPS, NCRB), DDR memory, XPHY, XPIO, GTY, MMCMs, etc.).

The NPI data is generated by the Vivado tool for the various NPI blocks. The NPI blocks that are present in Versal ACAP include NoC, DDR memory controller, XPHY, XPIO, GTY, MMCMs, etc. Before loading the PL configuration, ensure that PMC is configured.

The following table describes the content of the files, and is useful for debugging

Table 9: PL Configuration

File	Contents
PL CDO <.rcdo>	<ul style="list-style-type: none"> • PM init node command (Scan Clear, BISR, MBIST) for NoC domain • The PM init node commands for scan clear, house cleaning, BISR of PL domain • Register writes to configure CFU for CRC, compression etc • DMA Keyhole Xfer commands to load CFI data • Register writes/polls to CFU • If NPI not present: <ul style="list-style-type: none"> ◦ Global Signals (GMC_B, GRESTORE, GHIGH_B..): Register writes/polls • Global Signals (GWE, EOS, EN_GLOb): Register writes/polls
NPI CDO <.rnpi>	<ul style="list-style-type: none"> NPI data • NPI data load: DMA Writes/register writes • If CFI present: <ul style="list-style-type: none"> ◦ Global Signals (GMC_B, GRESTORE, GHIGH_B..): Register writes/polls • NPI Sequence: Register writes/polls • If CFI present: <ul style="list-style-type: none"> ◦ Global Signals (GWE, EOS, EN_GLOb): Register writes/polls • Isolation and PL reset commands

FPD Configuration

FPD CDO contains FPD configuration data with PM FPD initialization commands and FPD peripheral initialization data.

Note: PSM ELF dependency is already provided with LPD.

Table 10: FPD Configuration

File	Contents
FPD CDO	<ul style="list-style-type: none"> PS FPD PM init node commands (SC, BISR, MBIST) FPD configuration: Register writes/polls

Before loading the FPD CDO, ensure that the PMC and LPD are configured.

DFX Configuration

Dynamic Function eXchange (DFX) configuration enables one or more sub-regions of the device to be independently reprogrammed with new configuration data while all remaining regions (static or reconfigurable) remain active and unaffected. The DFX PDI can come either from PCIe, DDR memory, or the primary boot device. For loading the DFX PDIs, the XilLoader CDO commands can be used using the IPI interface. XilFPGA provides the required APIs to load DFX PDIs from Cortex-A72 or Cortex-R5F.

CPM Configuration

- CPM: CPM configuration CDO with register writes

Before loading the CPM CDO, ensure that the PMC, LPD and stage1 PL configuration are completed. Stage1 PL configuration should contain XPIPE, GT, and NoC configuration data in the NPI file.

Processor Subsystem Configuration

The APU and RPU come under the processor- based subsystems. For all processor-based subsystems, ELF files and/or CDOs are present as a part of the image. Processor details are read from image headers and the processor is initialized using XilPM commands.

The configuration consists of the following files.

Table 11: Processor Subsystem Configuration

File	Contents
PSM/RPU/APU CDO files	<ul style="list-style-type: none"> (Optional) Set of PM commands with nodes and requirements

Table 11: Processor Subsystem Configuration (cont'd)

File	Contents
PSM/RPU/APU ELF files	<ul style="list-style-type: none"> Cortex-R5F processor applications: Bare-metal/RTOS Cortex-A72 processor applications: ATF/U-Boot/Linux/Bare-metal

- For loading Cortex-R5F processor applications, ensure that the LPD configuration is completed.
- For loading Cortex-A72 processor applications, ensure that the FPD configuration is completed.
- For loading Cortex-R5F/Cortex-A72 using DDR memory, ensure that the PL (NPI with DDR configuration) configuration is completed.
- For loading Cortex-R5F/Cortex-A72 processor applications to the DDR memory, enable the NoC path from the PMC to the DDR memory in the design.

AI Engine Configuration

The AI Engine configuration consists of the following files.

Table 12: AI Engine Configuration

File	Contents
AI Engine NPI CDO	AI Engine Global Configuration using NPI <ul style="list-style-type: none"> PLL configuration AI Engine scan clear and memory clear using PM initialization node commands
AI Engine ELF	AI Engine tile program and data memory
AI Engine CDO	AI Engine array configuration <ul style="list-style-type: none"> Program memory configuration Data memory configuration DMA, locks, stream switch configuration AI Engine module register configuration

Before loading the AI Engine NPI CDO, ensure that PLM, LPD and PL (with NoC configuration in the NPI file) are completed. Also, enable the NoC path from the PMC to the AI Engine in the design for PLM to clear the AI Engine data memories.

PLM Software Details

This section explains PLM responsibilities, architecture, and execution details.

PLM Responsibilities

The PLM runs on the PMC PPU after the BootROM boots, and remains active throughout the lifetime of the system, beginning from the BootROM post-boot.

The PLM performs the system initialization and the boot and configuration of the Versal ACAP subsystems to include the APU, PL, and AI Engines. PLM handles authentication and decryption for secure boot as discussed in [Chapter 9: Security](#). The PLM also takes care of power management, partial reconfiguration, error management, subsystem restart, and health monitoring.

The PLM responsibilities include:

- Secure/non-secure boot
 - System initialization
 - Initialize NoC, configure NoC programming interface (NPI), DDR memory, and CPM
 - Configure AI Engines
 - Load PS images on the APU (Arm® Cortex-A72 processors) and the RPU (Cortex-R5F processors)
- The platform management tasks include:
 - Dynamic Function eXchange (DFX)
 - Error management
 - Power management
 - Subsystem restart
 - Health monitoring
 - Soft error mitigation (SEM)

PLM Architecture

The PLM is designed with a modular subsystem-based configuration, and task-based services. Each functionally distinct feature is designed as a module. The PLM application layer contains the module initialization and start-up tasks. Depending on the modules selected in the configuration, different modules are initialized. Modules can register event handlers, IPI handlers, CDO commands, and scheduler events with the PLM interface layer.

The PLM reads the PDI from the boot device and configures the system with the payloads present in the PDI. The following figure shows components that are part of the PLM ELF file.

Figure 27: PLM ELF Components

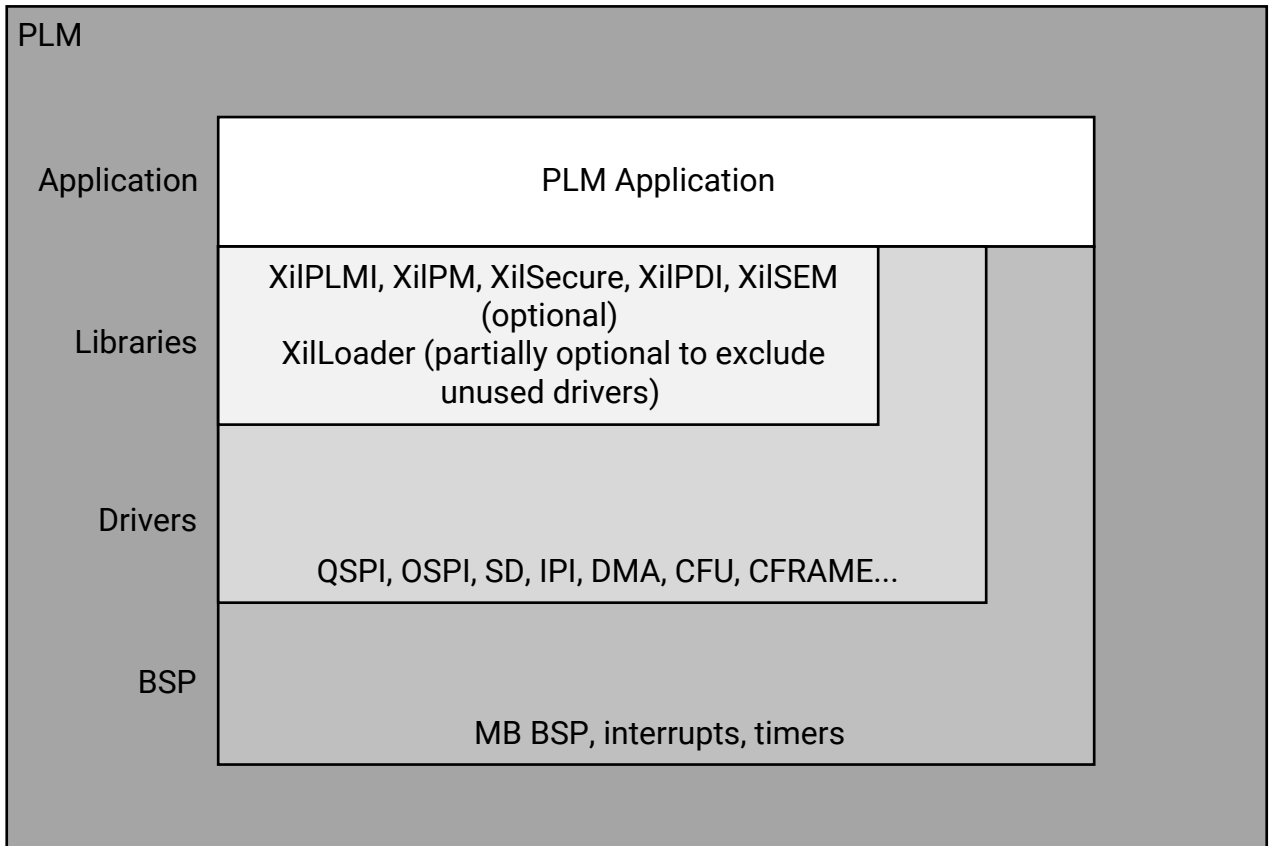

X23875-042720

Note: For modularity and possible feature reuse by other system software modules, the following PLM application modules are placed into separate libraries. Currently, these libraries are intended to be PLM internal only. Thus, APIs from these libraries are not intended to be called directly from other software layers outside of PLM.

- XilPLMI
- XilPDI
- XilLoader

The following table describes these components.

Table 13: PLM ELF Components

Software Component	Scope	Libraries/Drivers Used
PLM Application	<ul style="list-style-type: none"> • Start-up Events Registration • Configuration to include modules and debug levels • Event scheduling with queues 	All libraries listed in this table.

Table 13: PLM ELF Components (cont'd)

Software Component	Scope	Libraries/Drivers Used
XilPLMI	<ul style="list-style-type: none"> • PLM interface layer • Provides interface for parsing CDO files • Provides an interface to register handlers for section data • Provides an interface to register IPI events • Provides an interface to register interrupt events • Provides an interface to provide error responses, register error handlers • Provides interfaces to write and read CFI data to and from PL respectively 	BSP, PMC DMA, IPI, IOMODULE
XilLoader	<ul style="list-style-type: none"> • Responsible for loading boot PDI and subsystem images • Provides an interface for loading subsystem images from PDI • Interfaces with XilPLMI, XilSecure, XilPM and flash drivers 	SD/eMMC, QSPI, OSPI, USB, XilPLMI, XilPM
XilPM	Provides an interface to create and manage subsystems, MIO, clocks, power, and reset nodes settings.	XilPLMI
XilSecure	<ul style="list-style-type: none"> • Interfaces with secure module • Provides an interface to authenticate and decrypt Xilinx images 	PMC DMA
XilSEM	<ul style="list-style-type: none"> • Provides handlers for single event upset (SEU) events in the configuration RAM and NPI registers • Schedules handlers for SEU detection scan operations 	XilSecure, XilPLMI, CFAME, CFU

PLM Software

The PLM application performs processor initialization, module initialization, and executes start-up tasks.

- **Processor Initialization:** Includes initializing the stack and corresponding protections in hardware, enabling required interrupts and exceptions.
- **Start-up Tasks:** Start-up tasks include module initialization, executing PMC CDO, loading boot PDI, and running user hooks at predetermined places.
- **Modules:** Consists of module initialization functions that are included in the PLM to register the commands, interrupt handlers, and scheduler tasks with XilPLMI. The modules can:

- Register various commands using XilPLMI with the registered module ID. Commands can be part of PDI, or can come from the IPI message.
- Schedule tasks with PLMI.
- Register interrupt handlers for any PLM interrupts.
- **PLM Hooks:** In the PLM application, hook functions are present in predefined places for you to add your own code. Predefined user hooks are present at:

Table 14: PLM Hooks

Function	Description
XPlm_HookBeforePlmCdo	Executed before processing the PMC CDO file.
XPlm_HookAfterPlmCdo	Executed after processing the PMC CDO file.
XPlm_HookAfterBootPdi	Executed after loading the Boot PDI.

- **Exception Handling:** The exception handler is invoked when an exception occurs in the PPU. The handler logs the exceptions.

PLM Execution Flow

PLM execution is based on tasks. Initial start-up tasks are added to the PLM task queue after initializing the processor and programmable interval timers (MB internal). Start-up tasks include module initialization, executing PMC CDO, loading boot PDI and running user hooks at predetermined places. Post start-up events, the PLM enters service mode, where it enters sleep and waits for events. When woken up, the PLM enters the interrupt context, services the interrupt, and goes back to task queue to check for any task. When the task queue is empty, it goes to sleep.

The following sequence of events occur in the PLM:

1. Initialize processor, register interrupt handlers, enable interrupts
2. Execute start-up tasks
 - Initialize modules
 - Initialize modules, such as XilPLMI, XilPM, and XilLoader
 - For every module: Register CDO commands and interrupt handlers
 - Process the PMC CDO stored in the PMC RAM
 - Load the rest of the images in the boot PDI
 - Execute user hooks
3. Task dispatch loop (Wait for event)
 - Execute any tasks added to the task queue

PLM Errors

When errors are detected during PDI load, the PLM writes the error code to the PLM error register (PMC_GLOBAL.PMC_FW_ERR) and sets the NCR bit in the register. For any PPU MB exceptions that occurred during boot PDI load or while processing any service request, the PLM sets the NCR bit along with the error code in error register.

The default response for the PLM NCR bit is set to SRST. This can be changed to other actions using error management commands as per your requirements. In JTAG boot mode, irrespective of the response selected, the PLM will be in while loop for any error to facilitate debugging of the system.

PLM error can be read from the PLM error register (PMC_GLBOAL.PMC_FW_ERR) or using the JTAG `error_status` command. The error is logged in the following format.

```
Error code: 0xXXXXXXXX
```

- **XXXX**: Major error code. The PLM/XilLoader/XPLMI error codes are defined in `xplmi_status.h`.
- **YYYY**: Minor error code. This is the Libraries/Drivers error code defined in each module.

PLM Error Codes

The following table lists the PLMI, PLM, XilLoader, and XilSecure major error codes.

Table 15: PLM Error Codes

Value	Description
0x0	XPLM_SUCCESS: Success.
0x1	XPLM_FAILURE: Used internally for small functions.
0x2	XPLMI_TASK_INPROGRESS: Used internally to indicate task is in progress.
0x100	XPLMI_ERR_DMA_LOOKUP: Error when DMA driver lookup fails.
0x101	XPLMI_ERR_DMA_CFG: Error when DMA driver configuration fails.
0x102	XPLMI_ERR_DMA_SELFTEST: Error when the DMA self test fails. Error occurs when DMA is in reset and the PLM tries to initialize it.
0x103	XPLMI_ERR_IOMOD_INIT: Error when the I/O Module driver look up fails.
0x104	XPLMI_ERR_IOMOD_START: Error when I/O Module driver startup fails.
0x105	XPLMI_ERR_IOMOD_CONNECT: Error when I/O Module driver connection fails.
0x106	XPLMI_ERR_MODULE_MAX: Error when PLMI module is not registered. Can occur when invalid CDO CMD is processed by XilPLMI
0x107	XPLMI_ERR_CMD_APIID: Error when valid module and unregistered CMD ID is processed by XilPLMI.
0x108	XPLMI_ERR_CMD_HANDLER_NULL: Error when no command handler is registered by module for CDO CMD.

Table 15: PLM Error Codes (cont'd)

Value	Description
0x109	XPLMI_ERR_CMD_HANDLER: Error returned by the CDO CMD handler. For error returned by the CMD, check the PLM minor code.
0x10A	XPLMI_ERR_RESUME_HANDLER: Error returned by the CDO CMD resume handler. For error returned by the CMD, check the PLM minor code.
0x10B	XPLMI_ERR_CDO_HDR_ID: Error when valid CDO header ID is not present in CDO header. Can happen when different partition type is processed as CDO.
0x10C	XPLMI_ERR_CDO_CHECKSUM: Error when CDO header checksum is wrong. Can happen when CDO header is corrupted.
0x10D	XPLMI_ERR_UART_DEV_PM_REQ: Error when XilPM request device for UART fails. PM error code is present in PLM minor code.
0x10E	XPLMI_ERR_UART_LOOKUP: Error when UART driver lookup fails.
0x10F	XPLMI_ERR_UART_CFG: Error when UART driver configuration fails.
0x110	XPLMI_ERR_SSI_MASTER_SYNC: Error when SSI technology slave sync fails with master.
0x111	XPLMI_ERR_SSI_SLAVE_SYNC: Error when SSI technology master times out waiting for slaves sync point.
0x112	XPLMI_ERR_INVALID_LOG_LEVEL: Error when invalid log level is received in the logging command.
0x113	XPLMI_ERR_INVALID_LOG_BUF_ADDR: Error when invalid log buffer address is received in the logging command.
0x114	XPLMI_ERR_INVALID_LOG_BUF_LEN: Error when invalid log buffer length is received in the logging command.
0x115	XPLMI_ERR_IPI_CMD: Error when command execution through IPI is not supported.
0x116	XPLMI_ERR_REGISTER_IOMOD_HANDLER: Error when registering the I/O Module handler.
0x117	XPLMI_ERR_WDT_PERIODICITY: Invalid periodicity parameter for SetWDT command.
0x118	XPLMI_ERR_WDT_NODE_ID: Invalid node ID parameter for SetWDT command.
0x119	XPLMI_ERR_WDT_LPD_NOT_INITIALIZED: LPD MIO is used for WDT but LPD is not initialized
0x11A	XPLMI_ERR_INVALID_INTR_ID_DISABLE: Invalid Interrupt ID used to disable interrupt.
0x11B	XPLMI_ERR_INVALID_INTR_ID_CLEAR: Invalid Interrupt ID used to clear interrupt.
0x11C	XPLMI_ERR_INVALID_INTR_ID_REGISTER: Invalid Interrupt ID used to register interrupt
0x11D	XPLMI_ERR_DMA_XFER_WAIT: DMA transfer wait failed.
0x11E	XPLMI_ERR_NON_BLOCK_DMA_WAIT_SRC: Non block DMA transfer wait failed in Src channel.
0x11F	XPLMI_ERR_NON_BLOCK_DMA_WAIT_DEST: Non block DMA transfer wait failed in Dest channel WaitForDone.
0x120	XPLMI_ERR_NON_BLOCK_SRC_DMA_WAIT: Non block Src DMA transfer wait failed.
0x121	XPLMI_ERR_NON_BLOCK_DEST_DMA_WAIT: Non block Dest DMA transfer wait failed.
0x122	XPLMI_ERR_DMA_XFER_WAIT_SRC: DMA Xfer failed in Src Channel wait for done.
0x123	XPLMI_ERR_DMA_XFER_WAIT_DEST: DMA Xfer failed in Dest Channel wait for done.
0x124	XPLMI_ERR_UART_MEMSET: Memset of UartPsv Instance failed.
0x125	XPLMI_ERR_MEMCPY_COPY_CMD: Error during memcopy of CdoCopyCmd.
0x126	XPLMI_ERR_MEMCPY_CMD_EXEC: Error during memcopy of CdoCmdExecute.
0x127	XPLMI_ERR_MEMCPY_IMAGE_INFO: Error during memcopy of XLoader_ImageInfo
0x128	XPLMI_ERR_UART_PSV_SET_BAUD_RATE: Error during setting XUartPsv_SetBaudRate to XPLMI_UART_BAUD_RATE.

Table 15: PLM Error Codes (cont'd)

Value	Description
0x129	XPLMI_ERR_IO_MOD_INTR_NUM_REGISTER: Invalid I/O Module interrupt number used to register interrupt handler.
0x12A	XPLMI_ERR_IO_MOD_INTR_NUM_CLEAR: Invalid I/O Module interrupt number used to clear interrupt.
0x12B	XPLMI_ERR_IO_MOD_INTR_NUM_DISABLE: Invalid I/O Module interrupt number used to disable interrupt.
0x12C	XPLMI_NPI_ERR: NPI errors.
0x12D	XPLMI_IPI_CRC_MISMATCH_ERR: IPI CRC mismatch error.
0x12E	XPLMI_IPI_READ_ERR: Error in processing IPI request. It could be due to invalid message length error when CRC is enabled or invalid buffer address error from driver.
0x12F	XPLMI_ERR_UNALIGNED_DMA_XFER: Error during DMA involving of unaligned SrcAddr, DestAddr or number of words.
0x130	XPLMI_IPI_ACCESS_ERR: Access permissions failed for PLMI IPI command received.
0x131	XPLMI_ERR_TASK_EXISTS: Error when the task that is being added to scheduler already exists.
0x132	XPLMI_ERR_INVALID_TASK_TYPE: Error when invalid task type is used to add tasks in scheduler.
0x133	XPLMI_ERR_INVALID_TASK_PERIOD: Error when invalid task period is used to add tasks in scheduler.
0x200	XPLM_ERR_TASK_CREATE: Error when task create fails. This can happen when maximum tasks are created..
0x201	XPLM_ERR_PM_MOD: Error initializing the PM module.
0x202	XPLM_ERR_LPD_MOD: Error initializing the LPD modules.
0x203	XPLM_ERR_EXCEPTION: Exception has occurred during PLM initialization. EAR and ESR are printed on the UART console if enabled.
0x204	XPLM_ERR_NPLL_LOCK: Unable to lock NOC PLL for master SLR devices.
0x205	XPLM_ERR_STL_MOD: Error initializing the STL module.
0x206	XPLM_ERR_KEEP_ALIVE_TASK_CREATE: Error while creating the PSM keep alive task.
0x207	XPLM_ERR_KEEP_ALIVE_TASK_REMOVE: Error while removing the PSM keep alive task.
0x208	XPLM_ERR_PSM_NOT_ALIVE: PSM is not alive.
0x209	XPLM_ERR_IPI_SEND: Error while sending IPI.
0x300	XLOADER_UNSUPPORTED_BOOT_MODE: Error for unsupported boot mode. This error occurs if invalid boot mode is selected or boot mode peripheral is not selected in the CIPS wizard.
0x302	XLOADER_ERR_IMGHDR_TBL: Multiple conditions can cause this error: <ul style="list-style-type: none"> • If image header table has the wrong checksum • If PLM is unable to read the image header table
0x303	XLOADER_ERR_IMGHDR: Error if image header checksum fails.
0x304	XLOADER_ERR_PRTNHDR: Error if partition header checksum fails.
0x305	XLOADER_ERR_WAKEUP_A72_0: Error waking up the A72-0 during handoff. Check the PLM minor code for the PM error code.
0x306	XLOADER_ERR_WAKEUP_A72_1: Error waking up the A72-1 during handoff. Check the PLM minor code for the PM error code.
0x307	XLOADER_ERR_WAKEUP_R5_0: Error waking up the R5-0 during handoff. Check the PLM minor code for the PM error code.

Table 15: PLM Error Codes (cont'd)

Value	Description
0x308	XLOADER_ERR_WAKEUP_R5_1: Error waking up the R5-1 during handoff. Check the PLM minor code for PM error code.
0x309	XLOADER_ERR_WAKEUP_R5_L: Error waking up the R5-L during handoff. Check the PLM minor code for the PM error code.
0x30A	XLOADER_ERR_WAKEUP_PSM: Error waking up the PSM during handoff. Check the PLM minor code for the PM error code.
0x30B	XLOADER_ERR_PL_NOT_PWRUP: Error powering up the PL.
0x30C	XLOADER_ERR_UNSUPPORTED_OSPI: Error due to unsupported OSPI flash.
0x30D	XLOADER_ERR_UNSUPPORTED_OSPI_SIZE: Error due to unsupported OSPI flash size.
0x30E	XLOADER_ERR_OSPI_INIT: Error when OSPI driver lookup fails. This error occurs when OSPI is not selected in CIPS.
0x30F	XLOADER_ERR_OSPI_CFG: Error when OSPI driver CFG fails.
0x310	XLOADER_ERR_OSPI_SEL_FLASH: Error when OSPI driver is unable to select flash. Check minor code for the OSPI driver error code.
0x311	XLOADER_ERR_OSPI_READID: Error when OSPI ReadID fails.
0x312	XLOADER_ERR_OSPI_READ: Error when OSPI driver read fails. Check minor code for the OSPI driver error code.
0x313	XLOADER_ERR_OSPI_4BMODE: Error when OSPI is unable to enter/exit 4B mode.
0x314	XLOADER_ERR_QSPI_READ_ID: Error when QSPI read fails.
0x315	XLOADER_ERR_UNSUPPORTED_QSPI: Error when QSPI flash is not supported.
0x316	XLOADER_ERR_QSPI_INIT: Error when QSPI driver look up or configuration fails.
0x317	XLOADER_ERR_QSPI_MANUAL_START: Error when QSPI driver manual start fails.
0x318	XLOADER_ERR_QSPI_PRESCALER_CLK: Error when QSPI driver Prescaler setting fails.
0x319	XLOADER_ERR_QSPI_CONNECTION: Error when invalid QSPI connection listed other than single, dual, or stacked.
0x31A	XLOADER_ERR_QSPI_READ: Error when QSPI driver read fails.
0x31B	XLOADER_ERR_QSPI_LENGTH: Error when QSPI read length is greater than flash size.
0x31C	XLOADER_ERR_SD_INIT: Error when SD mount fails.
0x31D	XLOADER_ERR_SD_F_OPEN: Error when SD file open fails. This can happen when file is not present or read from SD fails. File system error code is present in the PLM minor code.
0x31E	XLOADER_ERR_SD_F_LSEEK: Error when f_seek fails while reading from SD card.
0x31F	XLOADER_ERR_SD_F_READ: Error while reading from SD card.
0x320	XLOADER_ERR_IMG_ID_NOT_FOUND: Error when Image ID is not found in subsystem while reloading image.
0x321	XLOADER_ERR_TCM_ADDR_OUTOF_RANGE: Error while loading to TCM and if address is out of range.
0x322	XLOADER_ERR_CFRAME_LOOKUP: Error when CFRAME driver look up fails.
0x323	XLOADER_ERR_CFRAME_CFG: Error when CFRAME driver CFG fails.
0x324	XLOADER_ERR_UNSUPPORTED_SEC_BOOT_MODE: Error due to unsupported secondary boot mode.
0x325	XLOADER_ERR_SECURE_METAHDR: Error when meta header secure validations fail.
0x326	XLOADER_ERR_GEN_IDCODE: Error caused due to mismatch in IDCODEs.
0x327	XLOADER_ERR_USB_LOOKUP: Error when USB lookup fails.

Table 15: PLM Error Codes (cont'd)

Value	Description
0x328	XLOADER_ERR_USB_CFG: Error when USB configuration initialize fails.
0x329	XLOADER_ERR_USB_START: Error when USB fails to start.
0x32A	XLOADER_ERR_DFU_DWNLD: Error when PDI fails to download.
0x32B	XLOADER_ERR_DEFERRED_CDO_PROCESS: Error occurred while processing the mask_poll CDO command but error is deferred till whole CDO processing is completed. For example, currently this deferred bit is generated from Vivado for DDR memory calibration done status.
0x32C	XLOADER_ERR_SD_LOOKUP: Error when SD look up fails.
0x32D	XLOADER_ERR_SD_CFG: Error when SD configuration fails.
0x32E	XLOADER_ERR_SD_CARD_INIT: Error when SD card init fails.
0x32F	XLOADER_ERR_MMC_PART_CONFIG: Error when MMC switch to user area in raw boot mode fails.
0x330	XLOADER_ERR_SEM_STOP_SCAN: Error while stopping the XilSEM scan.
0x331	XLOADER_ERR_SEM_CFR_INIT: Error while starting the XilSEM scan.
0x332	XLOADER_ERR_DELAY_ATTRB: Error when both delay handoff and copy to image.
0x333	XLOADER_ERR_NUM_HANDOFF_CPUS: Error when number of CPUs exceed maximum count.
0x334	XLOADER_ERR_OSPI_CONN_MODE: Error when OSPI mode is not supported.
0x335	XLOADER_ERR_OSPI_SEL_FLASH_CS1: Error when OSPI driver is unable to select flash CS1. Check minor code for OSPI driver error code.
0x336	XLOADER_ERR_OSPI_SDR_NON_PHY: Error when OSPI driver is unable to set the controller to SDR NON PHY mode.
0x337	XLOADER_ERR_OSPI_COPY_OVERFLOW: Error when source address in OSPI copy exceeds flash size.
0x338	XLOADER_ERR_SD_F_CLOSE: Error on closure of file in SD filesystem modes.
0x339	XLOADER_ERR_SD_UMOUNT: Error on unmounting filesystem.
0x33A	XLOADER_ERR_DMA_XFER: DMA transfer failed.
0x33B	XLOADER_ERR_DMA_XFER_SD_RAW: DMA transfer failed in SD Raw.
0x33C	XLOADER_ERR_CONFIG_SUBSYSTEM: Error while configuring subsystem.
0x33D	XLOADER_ERR_COPY_TO_MEM: Error on copying image to DDR with the copy to memory attribute enabled.
0x33E	XLOADER_ERR_DELAY_LOAD: When the image has delay load attribute set and the boot source is SMAP, SBI, PCIE or JTAG, the image is copied to PMC RAM to free it from the SBI buffers. Errors occurred during such copies to PMC RAM is denoted using this error code.
0x33F	XLOADER_ERR_ADD_TASK_SCHEDULER: Error while adding task to the scheduler.
0x340	XLOADER_ERR_SD_MAX_BOOT_FILES_LIMIT: Error code returned when search for bootable file crosses the maximum limit.
0x341	XLOADER_ERR_UNSUPPORTED_QSPI_FLASH_SIZE: Error when QSPI flash size is not supported.
0x342	XLOADER_ERR_PM_DEV_PSM_PROC: Failed in XPM Request Device for PM_DEV_PSM_PROC.
0x343	XLOADER_ERR_PM_DEV_IOCTL_RPU0_SPLIT: Failed in XPM Device Ioctl for RPU0_0 in SPLIT mode.
0x344	XLOADER_ERR_PM_DEV_IOCTL_RPU1_SPLIT: Failed in XPM Device Ioctl for RPU0_1 in SPLIT mode.
0x345	XLOADER_ERR_PM_DEV_IOCTL_RPU0_LOCKSTEP: Failed to XPM Device Ioctl for RPU0_0 in LOCKSTEP mode.
0x346	XLOADER_ERR_PM_DEV_IOCTL_RPU1_LOCKSTEP: Failed to XPM Device Ioctl for RPU0_1 in LOCKSTEP mode.
0x347	XLOADER_ERR_PM_DEV_TCM_0_A: Failed to XPM Request Device for PM_DEV_TCM_0_A.
0x348	XLOADER_ERR_PM_DEV_TCM_0_B: Failed to XPM Request Device for PM_DEV_TCM_0_B.

Table 15: PLM Error Codes (cont'd)

Value	Description
0x349	XLOADER_ERR_PM_DEV_TCM_1_A: Failed to XPM Request Device for PM_DEV_TCM_1_A.
0x34A	XLOADER_ERR_PM_DEV_TCM_1_B: Failed to XPM Request Device for PM_DEV_TCM_1_B.
0x34B	XLOADER_ERR_PM_DEV_DDR_0: Failed to XPM Request Device for PM_DEV_DDR_0.
0x34C	XLOADER_ERR_PM_DEV_QSPI: Failed to XPM Request Device for PM_DEV_QSPI.
0x34D	XLOADER_ERR_PM_DEV_SDIO_0: Failed to XPM Request Device for PM_DEV_SDIO_0.
0x34E	XLOADER_ERR_PM_DEV_SDIO_1: Failed to XPM Request Device for PM_DEV_SDIo_1.
0x34F	XLOADER_ERR_PM_DEV_USB_0: Failed to XPM Request Device for PM_DEV_USB_0.
0x350	XLOADER_ERR_PM_DEV_OSPI: Failed to XPM Request Device for PM_DEV_OSPI.
0x351	XLOADER_ERR_DEV_NOT_DEFINED: Device ID of the image to be loaded is not defined.
0x352	XLOADER_ERR_PARENT_QUERY_VERIFY: Failed to Query Parent ID of an image while verifying its Image UIDs.
0x353	XLOADER_ERR_INCOMPATIBLE_CHILD_IMAGE: Error while checking compatibility of an image with its parent.
0x354	XLOADER_ERR_NO_VALID_PARENT_IMG_ENTRY: Error if No Valid Parent Image entry is found in the ImageInfo table.
0x355	XLOADER_ERR_INVALIDATE_CHILD_IMG: Error while invalidating the Child Image entry
0x356	XLOADER_ERR_INVALID_PARENT_IMG_ID: Error when Invalid ParentImgID is obtained when queried for parent ImgID.
0x357	XLOADER_ERR_IMAGE_INFO_TBL_OVERFLOW: Error when ImageInfo table overflows.
0x358	XLOADER_ERR_FUNCTION_ID_MISMATCH: Error when the function ID given while loading an image from the DDR memory does not match with the ID stored in the image header.
0x359	XLOADER_ERR_MEMSET: Error during memset.
0x35A	XLOADER_DDR_COPY_UNSUPPORTED_PARAMS: Error when source address, destination address, or length params passed to <code>XLoader_DdrCopy</code> are not word aligned.
0x35B	XLOADER_ERR_INIT_CDO: <code>XPlmi_InitCdo</code> failed.
0x35C	XLOADER_ERR_INVALID_ELF_LOAD_ADDR: Error when the load address of the ELF is not valid.
0x35D	XLOADER_ERR_UNSUPPORTED_MULTIBOOT_FLASH_TYPE: Error due to unsupported flash type used with the <code>update multiboot</code> command.
0x35E	XLOADER_ERR_UNSUPPORTED_MULTIBOOT_PDISRC: Error due to unsupported PdiSrc used with the <code>update multiboot</code> command.
0x35F	XLOADER_ERR_UNSUPPORTED_FILE_NUM: Error due to unsupported Filenum used to update the multiboot register.
0x360	XLOADER_ERR_UNSUPPORTED_MULTIBOOT_OFFSET: Error when given multiboot offset is not valid (not a multiple of 32K).
0x360	XLOADER_ERR_UNSUPPORTED_MULTIBOOT_OFFSET: Error when given multiboot offset is not valid (not a multiple of 32K).
0x361	XLOADER_ERR_SECURE_NOT_ENABLED: Error as secure critical code is excluded and Secure boot is attempted
0x362	XLOADER_ERR_UNSUPPORTED_SUBSYSTEM_PDISRC: Error when unsupported PdiSrc is used for subsystem load.
0x363	XLOADER_ERR_PDI_LIST_FULL: Error when you are trying to add a new PdiAddr when the PdiList is full.
0x364	XLOADER_ERR_PDI_ADDR_EXISTS: Error when PdiAddr that is being added already exists in the PdiList.
0x365	XLOADER_ERR_PDI_LIST_EMPTY: Error when PdiList is empty and user is trying to remove a PdiAddr.

Table 15: PLM Error Codes (cont'd)

Value	Description
0x366	XLOADER_ERR_PDI_ADDR_NOT_FOUND: Error when the PdiAddr that is being tried to be removed does not exist in the PdiList.
0x367	XLOADER_ERR_RELEASE_PM_DEV_DDR_0: Failed to XPM Release Device for PM_DEV_DDR_0.
0x368	XLOADER_ERR_REQUEST_BOOT_DEVICE: Failed to Request Boot Device.
0x369	XLOADER_ERR_RELEASE_BOOT_DEVICE: Failed to Release Boot Device.
0x600	XLOADER_ERR_INIT_GET_DMA: Failed to get DMA instance at time of initialization.
0x601	XLOADER_ERR_INIT_INVALID_CHECKSUM_TYPE: Only SHA3 checksum is supported.
0x602	XLOADER_ERR_INIT_CHECKSUM_COPY_FAIL: Failed when copying checksum from flash device.
0x603	XLOADER_ERR_INIT_AC_COPY_FAIL: Failed when copying AC from flash device.
0x604	XLOADER_ERR_INIT_CHECKSUM_INVLD_WITH_AUTHDEC: Failed as checksum was enabled with authentication and encryption enabled.
0x605	XLOADER_ERR_DMA_TRANSFER: DMA transfer failed while copying.
0x606	XLOADER_ERR_IHT_AUTH_DISABLED: Authentication is not enabled for Image Header table.
0x607	XLOADER_ERR_IHT_GET_DMA: Failed to get DMA instance for IHT authentication.
0x608	XLOADER_ERR_IHT_COPY_FAIL: Failed when copying IHT AC from flash device.
0x609	XLOADER_ERR_IHT_HASH_CALC_FAIL: Failed to calculate hash for IHT authentication.
0x60A	XLOADER_ERR_IHT_AUTH_FAIL: Failed to authenticate IHT.
0x60B	XLOADER_ERR_HDR_COPY_FAIL: Failed when copying IH/PH from flash device.
0x60C	XLOADER_ERR_HDR_AES_OP_FAIL: Failed due to AES init or Decrypt init or key selection failure.
0x60D	XLOADER_ERR_HDR_DEC_FAIL: Failed to decrypt image header/partition.
0x60E	XLOADER_ERR_HDR_AUTH_FAIL: Failed to authenticate image header/partition.
0x60F	XLOADER_ERR_HDR_NOT_SECURE: Neither authentication nor encryption is enabled for image header/partition.
0x610	XLOADER_ERR_HDR_GET_DMA: Failed to get DMA instance for image header/partition authentication/decryption.
0x611	XLOADER_ERR_HDR_HASH_CALC_FAIL: Failed to calculate hash for image header/partition authentication.
0x612	XLOADER_ERR_HDR_NOT_ENCRYPTED: Image header/partition header is not encrypted.
0x613	XLOADER_ERR_HDR_AUTH_DISABLED: Authentication disabled for image header/partition header.
0x614	XLOADER_ERR_SEC_IH_READ_VERIFY_FAIL: Failed to read image header and verify checksum.
0x615	XLOADER_ERR_SEC_PH_READ_VERIFY_FAIL: Failed to read partition header and verify checksum.
0x616	XLOADER_ERR_PRTN_HASH_CALC_FAIL: Hash calculation failed for partition authentication.
0x617	XLOADER_ERR_PRTN_AUTH_FAIL: Partition authentication failed.
0x618	XLOADER_ERR_PRTN_HASH_COMPARE_FAIL: Partition hash comparison failed.
0x619	XLOADER_ERR_PRTN_DECRYPT_FAIL: Partition decryption failed.
0x61A	XLOADER_ERR_AHWROT_EFUSE_AUTH_COMPULSORY: PPK Programmed but eFUSE authentication is disabled.
0x61B	XLOADER_ERR_AHWROT_BH_AUTH_NOT_ALLOWED: PPK Programmed and BH authentication is enabled.
0x61C	XLOADER_ERR_AUTH_EN_PPK_HASH_ZERO: PPK not programmed and authentication is enabled.
0x61D	XLOADER_ERR_SHWROT_ENC_COMPULSORY: Encryption is disabled.

Table 15: PLM Error Codes (cont'd)

Value	Description
0x61E	XLOADER_ERR_KAT_FAILED: Known answer tests (KAT) failed.
0x61F	XLOADER_ERR_DATA_COPY_FAIL: Data copy to internal memory failed.
0x620	XLOADER_ERR_METAHDR_LEN_OVERFLOW: Failed when total size is greater than Metahdr length.
0x621	XLOADER_ERR_AUTH_JTAG_EFUSE_AUTH_COMPULSORY: JTAG authentication failed when PPK not programmed.
0x622	XLOADER_ERR_AUTH_JTAG_DISABLED: JTAG authentication disable efuse bit is set.
0x623	XLOADER_ERR_AUTH_JTAG_PPK_VERIFY_FAIL: JTAG authentication failed when verification of PPK.
0x624	XLOADER_ERR_AUTH_JTAG_SIGN_VERIFY_FAIL: JTAG authentication failed when verification of signature failed.
0x625	XLOADER_ERR_AUTH_JTAG_EXCEED_ATTEMPTS: JTAG authentication failed more than once.
0x626	XLOADER_ERR_AUTH_JTAG_GET_DMA: Failed to get DMA instance for JTAG authentication.
0x627	XLOADER_ERR_AUTH_JTAG_HASH_CALCULATION_FAIL: Hash calculation failed before signature verification.
0x628	XLOADER_ERR_AUTH_JTAG_DMA_XFR: Failed to get Auth JTAG data with DMA transfer.
0x629	XLOADER_ERR_MEMSET_SECURE_PTR: Error during memset for SecurePtr.
0x62A	XLOADER_ERR_GLITCH_DETECTED: Error glitch detected.
0x62B	XLOADER_ERR_AUTH_JTAG_SPK_REVOKED: Authentication failed when revoke id is programmed.
0x62C	XLOADER_ERR_METAHDR_KEYSRC_MISMATCH: Metaheader Key Source does not match PLM Key Source.
0x62D	XLOADER_ERR_PRTN_ENC_ONLY_KEYSRC: Invalid key source when encryption only is enabled.
0x62E	XLOADER_ERR_SECURE_NOT_ALLOWED: Error when state of boot is non secure.
0x62F	XLOADER_ERR_HDR_AAD_UPDATE_FAIL: Updating IHT as AAD failed during secure header decryption.
0x2XYZ	<ul style="list-style-type: none"> • 0x2 indicates failure in CDO command. • X indicates command module. <ul style="list-style-type: none"> ◦ 1 - PLM ◦ 2 - PM ◦ 3 - XiISEM ◦ 7 - Loader ◦ 8 - Error • YZ indicate handler ID of the CDO command.

Exception Handling

The exception handler is invoked when an exception occurs in the PPU. This handler logs the exception data and sets the firmware error bit in the Error Manager.

If an exception occurs before the boot PDI programming is complete, the PLM Error Manager updates the PMC MultiBoot register and triggers a system reset (SRST). However, if an exception occurs after the boot PDI programming is complete, then the PLM application runs in an infinite while loop.

PLM Event Logging

Event logging is categorized into the following features:

- Logging of PLM terminal prints
- Logging of trace events

Logging PLM Terminal Prints

The PLM supports logging of PLM terminal prints to memory. This feature helps you easily debug if the UART is not present. This logging is based on the log level that you enabled. Each print message is logged with the PLM timestamp. The following are the features that are supported as part of logging:

- **Configure print log level:** While building the PLM, you can decide the log level to use. Based on the PLM, the ELF file is generated. The PLM provides the provision to change the log level by sending the IPI command to it. The IPI command can reduce/expand the log level.
- **Configure debug log buffer memory:** By default, the log buffer is 16K in size in the PMC RAM, and the PLM logs the prints to the PMC RAM memory. This feature allows changing the debug log memory to a different memory location.
- **Retrieve debug log buffer:** You can retrieve the logged prints to the memory of your choice.
- **Retrieve debug log buffer information:** You can retrieve information of PLM prints logging.
- **Retrieve terminal prints:** You can retrieve terminal prints with the following command:

```
xsc t  
> plm log
```

Logging Trace Events

The PLM supports the logging of trace events to memory. This memory is different than the memory used for logging the PLM prints. Currently, the PLM logs only PDI load trace events and is timestamped. The following features are supported by the PLM as part of tracing:

- **Configure trace log buffer memory:** By default, the PLM logs the trace events to the PMC RAM memory. This feature allows you to change the trace log memory to a different memory location.
- **Retrieve trace log buffer:** Retrieve the logged trace events to a memory of your choice.
- **Retrieve trace log buffer information:** Retrieve information of trace events logging.

For examples of logging trace events, see [Event Trace Log Command Examples](#).

Trace Events Log Format

Table 16: Trace Events Log Format

Structure	
Trace event length including timestamp	Trace ID
Time stamp in milliseconds	
Time stamp in fraction	
Payload	
...	

Currently, the PLM logs only the list of images that are loaded as part of trace events logging.

Table 17: Trace Event Table

Trace Event ID	Trace Event Length	Payload
XPLMI_TRACE_LOG_LOAD_IMAGE = 0x1	3	Image ID

Event Trace Log Command Examples

The following examples show the structure of the event trace logs.

Example: Change the Log-Level to Debug Information

Structure
CMD - 0x020113 (Event logging command)
SubCmd - 0x1 (Sub command to change log level)
Arg1 - 0x4 (Change to Debug Info)

Example: Change Debug Log Buffer Address

The following command structure changes the log buffer address from 1M with a size of 512K.

Structure
CMD - 0x040113 (Event logging command)
SubCmd - 0x2 (Sub command to change log buffer address)
Arg1 - 0x0 (High Address)
Arg2 - 0x100000 (Low Address 1M)
Arg3 - 0x80000 (Size of log buffer 512K)

Example: Copy the Logged Data

Structure
CMD - 0x030113 (Event logging command)
SubCmd - 0x3 (Sub command to copy the log buffer to below specified address)
Arg1 - 0x0 (High Address)
Arg2 - 0x100000 (Low Address 1M)

Example: Get the Log Buffer Details

Structure
CMD - 0x010113 (Event logging command)
SubCmd - 0x7 (Sub command to get the event log buffer details)
Response Payload0: Command Status
Response Payload1: High Address
Response Payload2: Low Address
Response Payload3: Buffer offset till where the log is valid
Response Payload4: Log Buffer length
Response Payload5: Indicates that the log buffer is full

Event Logging IPI Command

Table 18: Event Logging Command

Structure			
Reserved[31:24]=0	Length[23:16]=4	PLM=1	CMD_EVENT_LOGGING=19
Sub Command			
Argument 1			
Argument 2			
Argument 3			

The PLM supports logging PLM Terminal Prints and Trace Events to separate buffers. This command configures the buffers for logging, and also retrieves buffer information.

Sub Command information is as follows:

- **1U**: Use this sub command to configure the log level of the PLM terminal during run time. This log level can be less than or equal to the log level set at compile time.
 - **Argument 1**: Log Level. This argument can be one or a combination of the following entities:
 - **0x1U**: Unconditional messages (DEBUG_PRINT_ALWAYS)

- **0x2U:** General debug messages (DEBUG_GENERAL)
- **0x4U:** More debug information (DEBUG_INFO)
- **0x8U:** Detailed debug information (DEBUG_DETAILED)
- **2U:** Use this sub command to configure the debug log buffer memory. By default this memory is configured to PMC RAM. You can change this memory as per your need.
 - **Argument 1:** High Address where PLM terminal prints are logged
 - **Argument 2:** Low Address where PLM terminal prints are logged
 - **Argument 3:** Length of Debug log buffer
- **3U:** Use this sub command is to copy the logged PLM prints from the Debug log buffer to where you need them.
 - **Argument 1:** High Address to which the log buffer data is copied
 - **Argument 2:** Low Address to which the log buffer data is copied
- **4U:** Use this sub command to retrieve the debug log buffer memory details where the PLM prints are logged. The response is as follows:
 - **Payload 0:** Command status
 - **Payload 1:** Debug log buffer High Address where the logging occurs
 - **Payload 2:** Debug log buffer Low Address where the logging occurs
 - **Payload 3:** Debug log buffer offset till where the logging occurs
 - **Payload 4:** Debug log buffer length
 - **Payload 5:** Indicates whether the debug log buffer is full
- **5U:** Use this sub command to configure the trace log buffer memory. By default, this memory is configured to PMC RAM. You can change this memory based on your need.
 - **Argument 1:** High Address where Trace events are logged
 - **Argument 2:** Low Address where Trace events are logged. Length of the Trace log buffer
- **6U:** Use this sub command to copy the logged trace events from the Trace log buffer to where you want them to be.
 - **Argument 1:** High Address to which you want to copy the trace log buffer data
 - **Argument 2:** Low Address to which you want to copy the trace log buffer data
- **7U:** Use this sub command is to retrieve the details of the trace log buffer memory where the trace events are logged. The response is as follows.

- **Payload 0:** Command status
- **Payload 1:** Trace log buffer High Address where the logging occurs
- **Payload 2:** Trace log buffer Low Address where the logging occurs
- **Payload 3:** Trace log buffer offset till where the logging occurred
- **Payload 4:** Trace log buffer length
- **Payload 5:** Indicates whether the trace log buffer is full

Error Manager

The Error Management module in the PLM initializes and handles the hardware-generated errors across the Versal platform, and provides an option to customize these error actions. The error management support is one of the important run-time platform management activity supported by PLM. In the hardware, there are two error status registers for PMC and two error status registers for PSM that contain the type of error occurrence. You can enable or disable an error from interrupting the PMC/PSM MicroBlaze processor. The Error Manager code present in PLMI, maintains an Error Table that contains Handler Pointer, Error Action and Subsystem (to shutdown or restart in case of SUBSYSTEM SHUTDOWN or SUBSYSTEM RESTART error action) information for each error that is routed to PMC and PSM. You can set any supported error action for each of the errors to take an appropriate action when an error occurs.

The possible error actions include:

- Generation of a power-on-reset (POR)
- Generation of a system reset
- Assertion of error out signal on the device
- No action (This disables all actions on the error and clear the corresponding status bit)

The PLM Error Manager provides APIs for assigning a default error action in response to an error. During initialization of the PLM modules, the PLMI initializes the Error Manager, enables errors, and sets error action for each error in accordance with the Error Table structure defined in the `xplmi_err.c` file.

Error Management Hardware

The Versal device has a dedicated error handler to aggregate and handle fatal errors across the SoC. The Error Manager handles the fatal errors using its hardware to trigger either SRST/PoR/ Error out, or an interrupt to PMC/PSM.

For more information, refer to the *Versal ACAP Technical Reference Manual* ([AM011](#)).

Error Management API Calls

The PLM Error Manager supports the following APIs:

- **XPImi_EmSetAction:** Use this API to set up the error action. This API takes Error Node ID, Error Mask, Action ID and Error Handler if the Action ID is Interrupt to PMC as input arguments. When this function is called, it disables the existing error actions, and sets the action specified in Action ID for the given error.
- **XPImi_EmDisable:** Use this API to disable all error actions for a given Error ID. This API takes Error ID as the input argument.

Error Management CDO Commands

The following CDO commands are supported by the PLM Error Management module.

Set EM Action

Table 19: Command: Set EM Action

Structure			
Reserved[31:24]=0	Length[23:16]=3	EM=8	CMD_SET_EM_ACTION=1
Error Event ID			
Reserved		Action ID	
Error Mask			

Use this command to set the error action for the specified Error Event ID and Error Mask. Refer to the following Error Event ID Table for list of Error Event IDs supported and Error Masks supported. Error management APIs are not supported over IPI, at present.

- **Actions:**
 - **Power On Reset:** 0x1
 - **System Reset:** 0x2
 - **Error Out:** 0x4
 - **None:** 0x7. Disable all actions on the Event and clear error status

Note: For PSM error events, the command returns failure if LPD is not initialized.

Register Notifier for EM Events

Table 20: Command: Register Notifier

Structure			
Reserved[31:24]=0	Length[23:16]=4	PMC_XILPM=2	CMD_PM_REGISTER_NOTIFIER=5
Node ID (Error Event ID)			
Event Mask (Error Mask)			
Argument 1			
Argument 2			

EM supports notifying a subsystem when registered error occurs, using the register notifier API supported by XilPM. Use this command to register for notifications when registered errors occur. Refer to the Error Event ID Table for a list of supported Error Event IDs and Error Masks.

- Node ID: Can either be a Device ID or Error Event ID. Use an Error Event ID for registering error events.
- Event Mask
 - For Device ID: Event Type
 - For Error Event ID: Error Mask
- Argument 1
 - For Device ID: Wake
- Argument 2
 - For Device ID: Enable

Register notifier of an event of Error Event ID enables the error event by clearing the corresponding PMC/PSM_ERR#N_STATUS bit and writes to the corresponding PMC/PSM_IRQ#N_EN. The notifier returns an event index (which is a bit that notify callback sets) to indicate the occurrence of the event.

The Register Notifier command works with the Notify Callback command.

For example, register notifier of Error Node GT_CR error event clears PMC_ERR1_STATUS.GT_CR, enables PMC_IRQ1_EN.GT_CR, and returns a number, for example, 5. Notify Callback sets bit 5 of the Event Status to indicate that the GT_CR error has occurred.

Notify Callback

Table 21: Command: Notify Callback

Structure			
Reserved[31:24]=0	Length[23:16]=4	PMC_LIBPM=2	CMD_PM_NOTIFY_CALLBACK
Node ID (Error Event ID)			
Event Status (Error Mask)			

On notify callback of an event of Error Event ID, the Error Node is disabled. For example, notification of the Error Node GT_CR error event disables the error by writing to PMC_IRQ1_DIS.GT_CR. You must re-register to be notified again.

Error Events

For a complete list of the available error events, refer to the *Versal ACAP Technical Reference Manual* ([AM011](#)).

PLM Interface (XilPLMI)

The PLM Interface (XilPLMI) is a low-level interface layer for the PLM main application and other PLM modules. XilPLMI provides the common functionality required for the modules that run with PLM. Each new module can register itself with the supported command handlers. These command handlers are executed based on the request received from other modules or from other subsystems.

XilPLMI also includes the CDO parser that parses and executes any CDO commands. XilPLMI implements the Generic Module that includes generic commands to be used by all other modules. The XilPLMI layer provides:

- Interface for parsing CDO files
- Implementation for general PLM CDO commands
- Interface to register handlers for commands that can be part of CDO and IPI
- Interface to set error actions and register notifications for error events
- Interface to schedule timer events
- Debug print levels and common utilities
- **Task Dispatcher Loop:** XilPLMI uses a very simple run-to-completion, time-limited priority task loop model, to get real-time behavior. The main program is a simple loop that looks up the next task from a queue of tasks, and calls the function to execute the task.

This model is simple in the sense that because all tasks are executed until they are done, there are no critical regions and no locking needed. Any code in the PLM can access any global data without having to worry about any other tasks being in the middle of updating the data.

The complexity with the run-to-completion model comes when a particular task needs to run longer than for the maximum allowed time limit (GTL). If that happens, split the tasks into multiple events.

Figure 28: Task Dispatch Loop

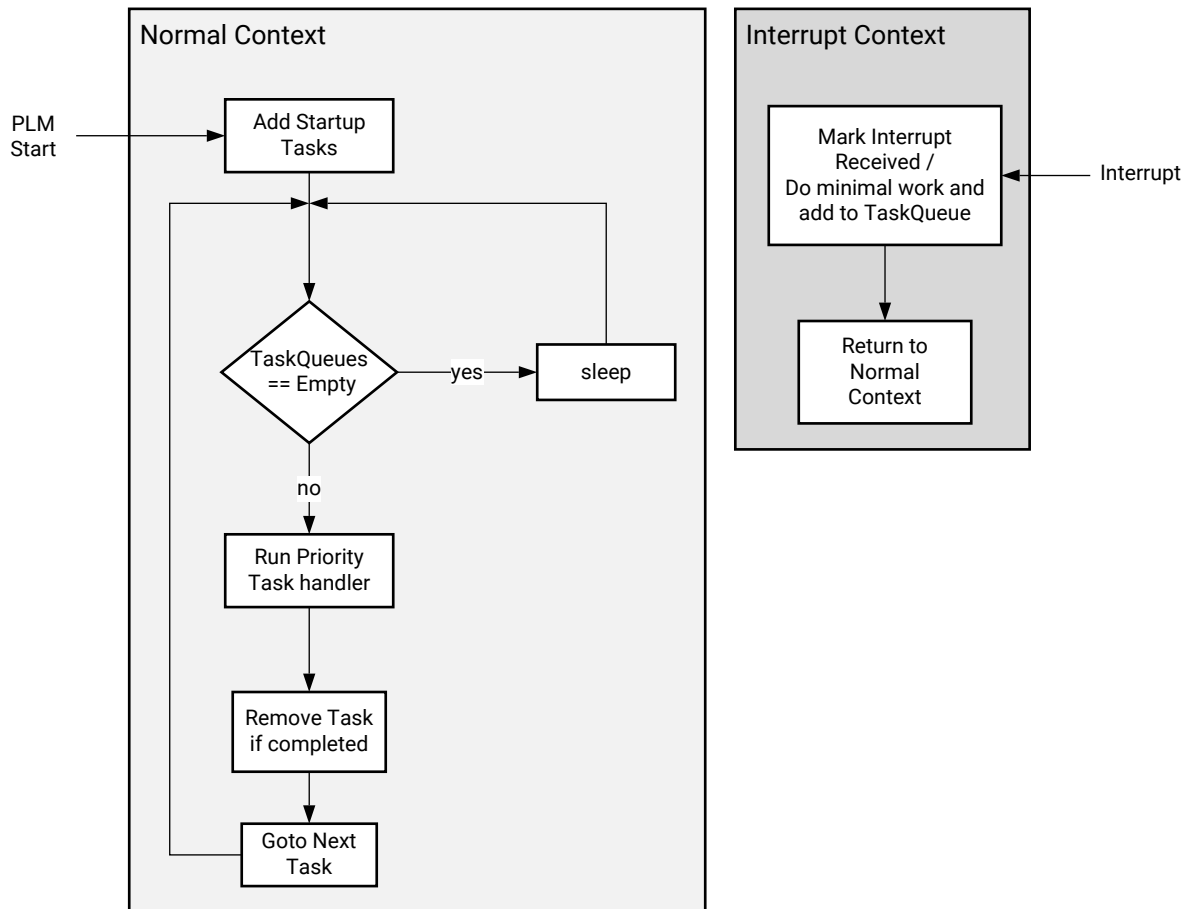

X23876-061021

- **Modules:** XilPLMI provides an interface layer for modules to register the commands for PLM. Commands can come from the CDO or IPI.
- **Configurable Parameters:**
 - **Modules:** Configurable to include or exclude modules, boot drivers based on your needs.
 - **Debug Prints:** Configurable to include multiple levels of print statements. For more information, refer to [PLM Build Flags](#).

- **CDO:** The CDO file contains the configuration information generated by the tools in the form of CDO commands. The module that supports the CDO registers itself to the PLM during the module initialization phase. XilPLMI provides the API to parse the CDO file and propagates the commands and its payload to the respective modules.
- **IPI Handling:** The PLM handles IPI interrupts, so that messages can be exchanged between the PLM and other processor on the Versal device. Data that is sent through IPI follows the CDO format.
- **Scheduler:** This is a simple timer-based function scheduler to support execution of periodic tasks. A scheduler is required by modules such as XilSEM to support periodic tasks such as SEU detection scan operations.

Note: Accuracy of the PMC IRO clock affects the scheduler accuracy.

- **PLM Watchdog Timer:** PLM has the framework to update the PLM health periodically. PLM toggles Multiplexed I/Os (MIO) to update health to an external Watchdog Timer (WDT). The PMC MIO is preferred but if a LPD MIO is used, then it is important to note that this WDT will be disabled when the PS is going down.

WDT can be enabled in the Vivado CIPS, and CIPS generates all the preceding required commands to enable WDT in PLM.

PLM WDT can be enabled by using the `SetWdt` CDO command with the parameters `MIO`, `PIN` and `periodicity`. Before running the `SetWdt` CDO command, ensure that MIO is configured as GPIO and load the corresponding PMC / LPD CDO. PDI loading is considered as Configuration mode and WDT is not supported during Configuration mode. Other operations considered as configuration mode are boot, partial PDI loading, and subsystem restart/resume. The minimum periodicity is 20 ms.

The PLM implementation is as follows:

- **Normal Context:**
 - PLM will set a variable to indicate ALIVE in between every task.
 - During PDI load, PLM mode is set to Configuration mode, and then reset to operational mode when PDI is loaded.
 - If LPD MIO is used, WDT is disabled during LPD shutdown.
 - If any task takes longer than the WDT periodicity, the ALIVE bit will be set and external WDT can reset the device.
- **Interrupt Context:**
 - Current scheduler period is 10 ms. This period indicates that for every 10 ms, the PLM gets a timer interrupt to schedule the tasks.
 - The WDT handler is called in the scheduler.

- When the WDT is enabled, the WDT handler performs following operation periodically based on configured periodicity (for example, for a periodicity of 100 ms, the following tasks run ~10 ms before expiry of periodicity)
 - When in configuration mode, the WDT handler toggles the MIO pin irrespective of the PLM alive status.
 - When in operation mode, the WDT handler toggles the MIO pin only when PLM alive status is set and clear the PLM alive status.

Table 22: Set PLM WDT

Command: Set PLM WDT			
Reserved [31:24]=0	Length [23:16]=2	PLM=1	CMD_SET_PLM_WDT=22
NODE Idx - PMC MIO PIN / LPD MIO PIN			
[31:16] Reserved		[15:0] Periodicity in ms - Default = 100 ms	

XilLoader

The PDI contains all the images that must be loaded into the system. PLM reads the PDI from the boot device and loads the images to the respective memories based on the image header.

Note: For more details on the PDI format, see the PDI section in [Chapter 7: Boot and Configuration](#).

The XilLoader provides an interface for the modules to load/start/look up the images present in the PDI. XilLoader also interacts with XilSecure (for secure boot), XilPM (for subsystem bring up), and boot drivers (for boot).

The following XilLoader functions are available:

- **XLoader_LoadAndStartSubSystemPdi:** This function takes PDI pointer as input. This API is called to load the images present in the PDI image, and start the subsystem based on the hand-off information present in the PDI. Based on the Image and Partition information present in the PDI, this API reads and loads each image partition from the PDI source. The API checks if the image requires hand-off and calls the XilPM APIs to perform the handoff.

The image can be a CDO partition or the subsystem image. If the image is a CDO partition, the API calls the CDO parser API from the PLMI. If the image is a subsystem executable partition, the API loads the partition to the respective subsystem's memory. After loading the image, this API reads the CPI ID and hand-off address from the PDI, and calls the XilPM APIs with this information. If there is any error while loading or starting the image, this API returns the appropriate error code. Otherwise, this API returns SUCCESS.

- XLoader_RestartImage:** Each image has its own unique ID in the PDI. This function takes the Image ID as input to identify image in the PDI and restart it. Based on the Image ID, this API parses through the subsystem information stored during boot, and obtains the image number and the partition number that is present in the PDI. This API then reads the Image partitions and loads them. In addition, this API checks if the image requires hand-off, and calls the XilPM APIs accordingly. If there is any error while restarting the image, the API returns an appropriate error code. Otherwise, the API returns SUCCESS.

Sequence of Operations

The following is the sequence of operations that happen between the loader and other components.

- Based on the boot mode, the corresponding flash drivers are used to read the PDI.
- Based on the image headers, the loader gets the CPU details for an image.
- The loader uses the XilPlmi API for loading CDOs, and the XilPM API to start/stop the processors, and to initialize memory.
- The loader uses XilSecure to perform checksum, authentication, or decryption on the image.

Boot Drivers

XilLoader implements the following high-level boot device interface APIs that are called to initialize the boot device, and to load the images from the boot device to the corresponding subsystem memory. These APIs internally call the driver APIs as required.

- Flash Drivers:** QSPI, OSPI, SD/eMMC drivers are used to read the images from the flash device.
- PMC DMA:** APIs for PMC DMA related functionality.

Image Store

The PLM supports storing of images in the DDR memory during boot time so that the images can be used later in cases like delay load, subsystem restart, and suspend/resume. This helps in reducing the load times because loading images from the DDR memory is faster than loading them from other boot devices. In bif of a Boot PDI, copy attribute can be used to specify the DDR memory address at which a particular image needs to be stored.

You can also create or upgrade the image store during run time by using partial PDIs. The address of the partial PDI loaded in the DDR memory can be passed to PLM using an IPI command and the PLM adds it into a PDI list. So, the PLM maintains a PDI list whose first entry is Boot PDI and rest of them are the PDI Addresses added during run time. During any of these use cases where a image has to be restarted, the PLM goes through the PDI list from the latest entry and checks if the required image is present in the PDI and loads it. If an image is not found or if the loading fails, the PLM performs a fallback to the next entry of the list until it reaches the Boot PDI.

XilLoader/IPI CDO Commands

The following table provides the list of commands that are supported by the XilLoader.

Table 23: XilLoader/IPI CDO Commands

Command	API ID
Load Partial PDI	1
Load DDR Copy Image	2
Update Multiboot	8
ImageStore PDI	9
Remove ImageStore PDI	10

Load Partial PDI

The Load Partial PDI CDO command with IPI interface is used to support partial reconfiguration from DDR and flash devices. Partial reconfiguration request comes through IPI command with source field specified as DDR/QSPI/OSPI flashes. The PdiSrc field will have the same values as boot mode values when used as primary boot device.

Table 24: Load Partial PDI Command Structure

Structure			
Reserved[31:24]=0	Length[23:16]=3	XilLoader=7	CMD_XILLOADER_LOAD_PPDI = 1
PdiSrc - 0x1=QSPI24, 0x2=QSPI32, 0x8=OSPI, 0xF for DDR			
High PDI Address			
Low PDI Address			

Load DDR Copy Image

Table 25: Load DDR Copy Image Command Structure

Structure			
Reserved[31:24]=0	Length[23:16]=1	XilLoader=7	CMD_XILLOADER_LOAD_DDR_COPY_IMG = 2
Image ID			
Function ID			

Update Multiboot

PLM provides a command for user applications to update the multiboot value during run-time. In case of QSPI, OSPI, and SD/eMMC raw boot devices, the value indicates the 32K offset in the flash device that is to be used to boot the image. For SD/eMMC file system, the value denotes the number that is appended to the BOOT.BIN image name. After updating the multiboot value, you can perform SRST to let the BootROM boot the image from the given multiboot offset in the respective boot device.

Table 26: Update Multiboot Command Structure

Structure			
Reserved[31:24]=0	Length[23:16]=2	XilLoader=7	CMD_UPDATE_MULTIBOOT=8
Reserved[31:16]=0	BootMode[15:8]	Reserved[7:4]=0	[3:0] - Flash Type - 0: RAW, 1: FS, 2: RAW BP1, 3: RAW BP2
Image location (In case of SD/eMMC File System - File Number, Remaining cases - PDI Location in the device)			

This command updates the PMC_GLOBAL.PMC_MULTI_BOOT Multiboot register. BootMode is the boot mode value corresponding to the boot device where the image is present. Flash Type is ignored in case of QSPI/OSPI as it supports only raw mode by default.

The image location for SD/eMMC file system should be the file number which is appended to BOOT.BIN file name. Up to 8191 files (`boot0001.bin` to `boot8190.bin`) are allowed. For all other cases, the image location is the address of the PDI in the respective device. It should be in multiples of 32 KB. The following boot modes are currently supported:

- QSPI
- OSPI
- SD
- eMMC

The response structure is as follows:

Table 27: Update Multiboot Response Structure

Structure
Status

Upgrade ImageStore

Add ImageStore

The ImageStore can be upgraded during run-time with any partial PDI address present in the DDR. The PLM maintains a list of PDIs (PDI addresses). You can add or remove any PDI address in the DDR to or from the list through IPI commands.

While restarting an image, the PLM checks if there are any entries in the list. If there are any entries, it goes to the latest PDI in the list and tries to restart an image from that PDI. If a failure occurs, fallback happens to the next possible image in the list, and if no more entries are left in the PDI list, the PLM tries to restore the image from the DDR locations mentioned in the BootPDI as CopyToMem addresses.

The following are the ImageStore PDI commands:

Table 28: Add ImageStore PDI Command Structure

Structure			
Reserved[31:24]=0	Length[23:16]=3	XilLoader=7	CMD_ADD_IMG_STORE_PDI=9
High PDI Address			
Low PDI Address			

This command adds PDI address to the list of Image Store PDIs that are maintained by the PLM. During restore or reload of a image, the PLM first checks this dynamically added list of PDIs to get the required image. In case of any failure, it falls back to the next possible PDI. If a valid entry is not present, it uses Boot PDI, which is the first entry in the list.

The response structure is as follows:

Table 29: Add ImageStore PDI Response Structure

Structure
Status

Remove ImageStore

Table 30: Remove ImageStore PDI Command Structure

Structure			
Reserved[31:24]=0	Length[23:16]=2	XilLoader=7	CMD_ADD_IMG_STORE_PDI=10
High PDI Address			
Low PDI Address			

This command removes a PDI address from the list of Image Store PDIs that are maintained by the PLM. During restoring or reloading an image, the PLM first checks this dynamically added list of PDIs to get the required image. In case of any failure, it falls back to the next possible PDI. If a valid entry is not present, it uses Boot PDI, which is the first entry in the list.

The response structure is as follows:

Table 31: Remove ImageStore PDI Response Structure

Structure
Status

Deferred Image Loading

The PLM supports the Copy to Memory and Deferred Image Handoff features. Based on the scenario, you might have to defer loading a certain subsystem image in the PDI after a certain boot milestone, or defer the handing off to a certain subsystem image. This establishes a certain boot order and can be used to decrease boot time.

Copy to Memory

Images with the `copy = <DDR address>` attribute specified against them in the BIF file are stored at the specified address in DDR and then loaded during boot PDI load. Specifying the `copy` attribute takes a backup of the image in DDR, while loading the image. Specifying `delay_load` in BIF for an image skips the loading of the image altogether.

Specifying `copy = <DDR address>`, `delay_load` in BIF takes the back up of the image in DDR and skips loading of the image altogether.

Images are loaded by an IPI command `0x10702` that takes the `image ID`, `function ID` as an argument. The IPI command loads and executes these images after all other images start their run. You cannot specify `delay_load` and `delay_handoff` simultaneously for an image.

However, you can specify `copy` and `delay_handoff` simultaneously for an image.

For partial PDIs, the Copy to Memory feature is not supported.

Deferred Image Handoff

You can pass the `delay_handoff` attribute to the selected image IDs in the BIF file, which is an input to Bootgen. The PLM reads the `delay_handoff` attribute and defers the handoff of the images till the end of boot PDI load. In other words, the images with the `delay_handoff` attribute specified, only start running after the images without the `delay_handoff` and `copy = 1` attributes start their run. Deferred Image Handoff is supported for both full PDIs and partial PDIs.

XiIPM

Platform Management (XiIPM) is a library that provides interfaces to create and manage subsystems, MIO, Clocks, Power and Reset settings of nodes. The following table provides the list of commands supported by this module. For details about Platform Management, refer to the [Chapter 10: Versal ACAP Platform Management](#).

Table 32: Platform Management Modules

Command Name	API ID
Node-Related Commands	
PM_GET_NODE_STATUS	3
PM_REQUEST_SUSPEND	6
PM_SELF_SUSPEND	7
PM_ABORT_SUSPEND	9
PM_REQUEST_WAKEUP	10
PM_SET_WAKEUP_SOURCE	11
PM_REQUEST_NODE	13
PM_RELEASE_NODE	14
PM_SET_REQUIREMENT	15
PM_SET_MAX_LATENCY	16
Reset Control Commands	
PM_RESET_ASSERT	17
PM_RESET_GET_STATUS	18
Pin Control Commands	
PM_PINCTRL_REQUEST	28
PM_PINCTRL_RELEASE	29
PM_PINCTRL_GET_FUNCTION	30
PM_PINCTRL_SET_FUNCTION	31
PM_PINCTRL_CONFIG_PARAM_GET	32
PM_PINCTRL_CONFIG_PARAM_SET	33
Generic Commands	
PM_GET_API_VERSION	1
PM_REGISTER_NOTIFIER	5
PM_FORCE_POWERDOWN	8
PM_SYSTEM_SHUTDOWN	12
PM_INIT_FINALIZE	21
PM_GET_CHIPID	24
PM_QUERY_DATA	35
PM_IOCTL	34

Table 32: Platform Management Modules (cont'd)

Command Name	API ID
Clock Control Commands	
PM_CLOCK_ENABLE	36
PM_CLOCK_DISABLE	37
PM_CLOCK_GETSTATE	38
PM_CLOCK_SETRATE	39
PM_CLOCK_GETRATE	40
PM_CLOCK_SETDIVIDER	41
PM_CLOCK_GETDIVIDER	42
PM_CLOCK_SETPARENT	43
PM_CLOCK_GETPARENT	44
PM_PLL_SET_PARAMETER	48
PM_PLL_GET_PARAMETER	49
PM_PLL_SET_MODE	50
PM_PLL_GET_MODE	51

XilSecure

The XilSecure library is a library of security drivers that access the hardened cryptographic cores to support the AES-GCM 256-bit/128-bit engine, the RSA/ECC engine that supports RSA-4096, RSA-3076, RSA-2048 as well as ECDSA NIST P-384 and NIST P-521, and the SHA3/384 engine.

For more information, see [Chapter 9: Security](#).

XilSEM

The Xilinx Soft Error Mitigation (XilSEM) library is a pre-configured, pre-verified solution to detect and optionally correct soft errors in Configuration Memory of Versal ACAPs.

See the *OS and Libraries Document Collection* ([UG643](#)) for more information.

PLM Usage

This section describes building PLM software using the Vitis™ tool including the build flags to use, the PLM memory layout and PLM reserved memory and registers. To perform the PLM build using the Vitis tool, refer to the *Xilinx Embedded Design Tutorials: Versal Adaptive Compute Acceleration Platform* ([UG1305](#)).

PLM Build Flags

The following table lists the important build flags in PLM and their usage. For a complete list of build flags, see the `xplmi_config.h` file in the XilPLMI library. To apply changes to the build flags, rebuild the BSP and the PLM application.

Table 33: PLM Build Flags

Flag	Description	Prerequisites	Default Setting
PLM_PRINT	When enabled, prints the PLM header and any mandatory prints.	None	Disabled
PLM_PRINT_NO_UART	Enable this definition to disable prints from UART. Prints to memory are still enabled as defined by PLM DEBUG macros.	None	Disabled
PLM_DEBUG	Prints basic information and any error messages.	None	Enabled
PLM_DEBUG_INFO	Prints with format specifiers in addition to the basic information.	None	Disabled
PLM_DEBUG_DETAILED	Prints detailed information.	None	Disabled
PLM_PRINT_PERF	Prints the time taken for loading the partitions, images and tasks.	Any of the above-mentioned debug print flags need to be enabled	Enabled
PLM_QSPI_EXCLUDE	When this flag is enabled, the QSPI code is excluded.	None	Disabled
PLM_SD_EXCLUDE	When this flag is enabled, the SD code is excluded.	None	Disabled
PLM_SECURE_EXCLUDE	When you enable this definition, secure code (AES, RSA, ECDSA) code is excluded. SHA3 code is still included to support checksum cases.	None	Disabled
PLM_SEM_EXCLUDE	When this flag is enabled, the XiSEM code is excluded.	None	Disabled
PLM_DEBUG_MODE	Disables soft reset in case of error during Base PDI loading. This will be helpful in maintaining the system state for debugging.	None	Disabled

Table 33: PLM Build Flags (cont'd)

Flag	Description	Prerequisites	Default Setting
PLM_PRINT_PERF_POLL	Prints the time taken for any poll for MASK_POLL command.	None	Disabled
PLM_PRINT_PERF_DMA	Prints the time taken for PMC DMA, QSPI, OSPI	None	Disabled
PLM_PRINT_PERF_CDO_PROC ESS	Prints the time taken to process the CDO file.	None	Disabled
PLM_PRINT_PERF_KEYHOLE	Prints the time taken to process keyhole command. Keyhole command is used for Cframe and slave SLR image loading.	None	Disabled
PLM_PRINT_PERF_PL	Prints the PL Power status and House clean status.	None	Disabled

PMC Memory Layout

This section contains the approximate details of the PMC memory layout and the PLM memory footprint, with the various PLM build options.

The following figure shows the PMC memory layout.

Figure 29: PMC Memory Layout

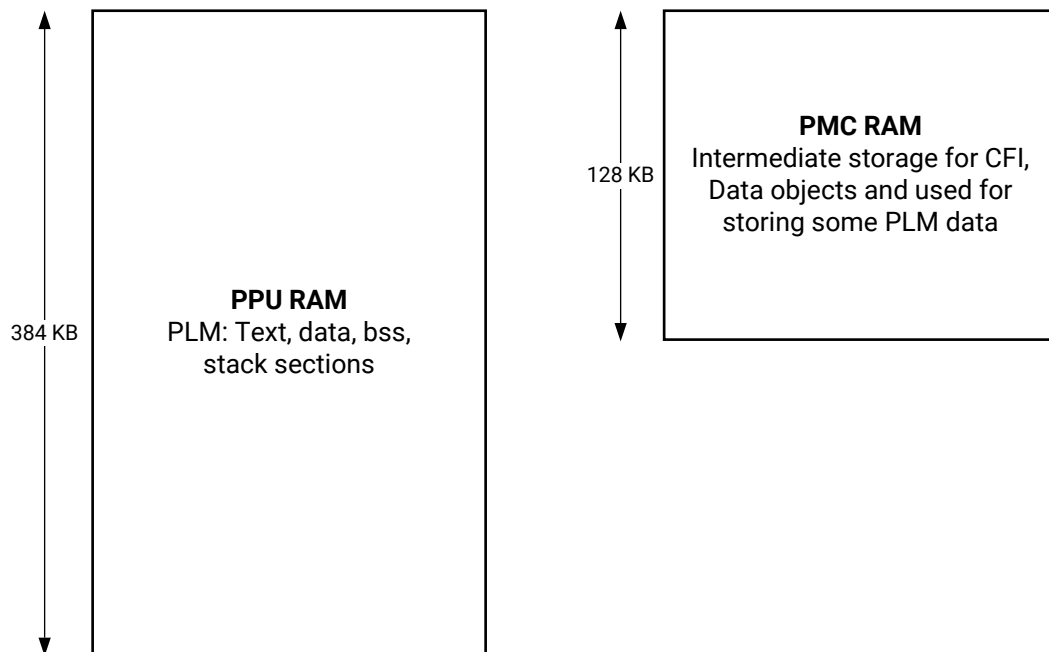

X23867-052421

In the PLM, the PLM_DEBUG and PLM_PRINT_PERF build flags along with all modules, are enabled by default.

Services Flow

All interrupts are added as events and are run in the normal context. The PLM calls the appropriate handler based on the interrupts or inter-processor interrupts (IPIs) received.

Security

This chapter describes the Versal™ device features that you can leverage to address security during the application boot time and run time.

Refer to the *Versal ACAP Security Manual* (UG1508) for the production readiness of the desired security feature as well as its detailed usage instructions. You can download it from the [Design Security Lounge](#) (registration required).

Security Features

The Versal device provides several security-related features. One of the biggest security features that Versal ACAP provides is the hardened cryptographic engines that support:

- Advanced encryption standard galois counter mode (AES-GCM) 128-bit and 256-bit, and supports additional authenticated data (AAD).
- RSA 2048, 3072, and 4096
- Elliptic curve cryptography (ECC) engine that supports multiple curves
- SHA3/384 Hashing

Because of the hardened cryptographic engines in Versal ACAP, Xilinx provides an associated set of security-related drivers that use the cryptographic engines either during secure boot or run time. During secure boot, the ROM, the PLM, and U-Boot can take advantage of these cryptographic features. During run time, these drivers can be accessed directly through a bare-metal application or indirectly depending on the architecture configuration. This can include using an operating system, a hypervisor, trusted execution environment, etc. For example, in a Linux application, the application can call the Linux kernel, which would send an IPI request to the PLM where the security library runs. This is just one example of accessing the security libraries from run time; the options are numerous because Versal ACAP is highly configurable.

If there are any security features not provided by Xilinx, you can take advantage of the PL to implement additional security features or use the built-in Armv8 cryptographic extensions and the Arm NEON extensions in the Arm Cortex-A72 processors.

Known Answer Tests

The Versal ACAP has the ability to perform KATs on the cryptographic engines before using them. The KAT checks the integrity of the hardened cryptographic engines before operating on the data.

The KAT includes the following tests:

- SHA3/384
- RSA-4096
- ECDSA with the NIST P-384 curve
- AES-GCM 256-bit with and without the differential power analysis (DPA) counter measure enabled

KATs can be run during boot. These APIs can be called explicitly from an application running on either Cortex-A72 or Cortex-R5F processors.

Secure Boot

On Versal devices, secure boot ensures the confidentiality, integrity, and authentication of the firmware and software loaded onto the device. The root of trust starts with the BootROM, which authenticates and/or decrypts the PLM depending on the secure boot mode selected. The Versal ACAP devices offer two secure boot modes: Asymmetric Hardware Root of Trust (A-HWRoT) and Symmetric Hardware Root of Trust (S-HWRoT).

The A-HWRoT boot mode forces the device to only boot images that are authenticated using RSA or ECDSA. The S-HWRoT boot mode forces the device to only boot images that have the PLM and MetaHeader encrypted using a black (encrypted) eFUSE key.

Encryption of partitions beyond the PLM and MetaHeader is defined by the MetaHeader that is authenticated using AES-GCM. Secure boot is important for two reasons.

1. Ensures that the software being loaded onto a device is allowed to be loaded, which prevents malicious code from running on the device
2. Protects the OEM IP because the software is stored in an encrypted fashion, which prevents the OEM IP from being stolen.

Additionally, if secure boot is not desired, then software can at least be validated with a simple checksum; however, keep in mind that the protections listed above do not apply when using this method of boot. The following table highlights the possible secure boot configurations.

Table 34: Cumulative Secure Boot Operations

Boot Type	Operations			Hardware Crypto Engines
	Authentication	Decryption	Integrity (Checksum Verification)	
Non-secure	No	No	No	N/A
Hardware Root-of-Trust (HWRoT)	Yes	Optional	Integrity via Authentication	N/A
Asymmetric Hardware Root-of-Trust (A-HWRoT)	Yes	Optional	Integrity via Authentication	RSA/ECDSA and SHA3
Symmetric Hardware Root-of-Trust (S-HWRoT)	Yes via GCM and eFUSEs	Yes Must use PUF KEK	Integrity via Authentication	AES-GCM/PUF
A-HWRoT + S-HWRoT	Yes	Yes Must use PUF KEK	Integrity via Authentication	RSA/ECDSA, SHA3, AES-GCM, PUF

Note: Checksum is used to verify the integrity of the image loaded and is not a secure boot mode.

The Versal ACAP system uses the following hardware cryptographic blocks in the secure boot process:

- **SHA Hardware Accelerator:** Calculates the SHA3/384 hash on images, used in conjunction with the RSA or elliptical curve cryptography (ECC) engine for signing.
- **ECDSA-RSA Hardware Accelerator:** Authenticates images using a public asymmetric key. Either RSA-4096 or ECDSA with curve NIST P-384 can be used.

In addition to NIST-P384, NIST-P521 curve can also be used by the PLM for other images. P-381 is required for the MetaHeader, the PMC CDO, and the PLM. For all the other partitions, you can use P-521.

- **AES-GCM Hardened Crypto Block:** Decrypts images using a 256-bit key, and verifies the integrity of the decrypted image using the GCM tag.

In addition to AES-GCM 256-bit, AES-GCM 128-bit can also be used by the PLM for other images. AES-GCM 256-bit is required for the MetaHeader, the PMC CDO, and the PLM. For all the other partitions, use AES-GCM 128-bit.

Checksum Verification

Versal ACAP uses the SHA-3 digest to verify the data integrity of Versal device images. If the checksum verification is enabled in the PDI, the PLM calculates the SHA-3 digest and verifies it with the expected SHA-3 digest that is the part of PDI.

The checksum option does not work with A-HWRoT and/or S-HWRoT because these methods already perform data integrity checks.

Asymmetric Hardware Root-of-Trust (A-HWRoT) (Authentication Required)

The Versal device image's SHA3 hash is signed with the private RSA/ECDSA key to generate a signature and is placed into the Versal device image. Upon boot, the SHA3 hash is calculated on the image, and the signature stored in the image is passed into the RSA/ECDSA engine using the public key. If both the calculated SHA3 hash and the verified signature match, the image is valid.

There are two public key types used in Versal ACAP: the primary public key (PPK) and the secondary public key (SPK). Each image is assigned its own or the same SPK. For example, the PLM could be assigned to use SPK0 and an application for the Cortex-A72 could be assigned the same SPK0 or its own SPK such as SPK1.

In the Versal device, there is storage for three PPK hashes in the eFUSE memory: PPK0, PPK1, and PPK2. If you program any of the PPK eFUSE bits, the A-HWRoT is forced at boot time, and therefore, all software needs to be authenticated before it is loaded into the Versal device. The asymmetric key pair can be either RSA 4096 or ECDSA-P384 curve. For the three PPK choices, a combination of RSA and ECDSA hash values are allowed to be programmed.

RSA Engine

During boot, only RSA-4096 is supported. However, post boot the RSA engine is accessible and supports private and public key operations of sizes 2048, 3072, and 4096 bits.

Elliptic Curve Cryptography Engine

During boot, the elliptic curve digital signature algorithm (ECDSA) is only supported with the NIST P-384 curve for the PLM, while other images can be signed using either the NIST P-384 curve or the NIST P-521 curve. However, post boot, the elliptic curve cryptography (ECC) engine is accessible, and supports a variety of curves in addition to the NIST P-384 curve. Supported curves are NIST P-384 and NIST P-521.

Key Revocation

In eFUSEs, you have only three PPK choices to store the hash value of the primary public key and up to two of those values can be revoked. If another revocation occurs, the device is no longer bootable. If a PPK is compromised, you can revoke the public key by setting the corresponding PPK revocation bit in eFUSEs.

To revoke the SPK, you program the corresponding eFUSE bit in the Revocation ID. There are 256-bits [0-255] in total, so you can revoke the SPK 255 times. The 0-bit of Revocation ID represents KEY 0, the 32nd bit of Revocation ID represents KEY 32, etc.

Encryption

Versal devices include an AES-GCM hardware engine that supports confidentiality, authentication, and integrity. GCM assists in the authentication and integrity check. You can use the engine to encrypt or decrypt data with the use of a symmetric key and initialization vector pair boot or post-boot. The boot flow is required to use a key size of 256-bit and a 96-bit initialization vector, through loading of the PLM, and 256-bit or 128-bit key sizes are allowed for additional firmware and software. Post boot, the engine supports both 256-bit and 128-bit key sizes. Additionally, the AES-GCM engine supports AAD.

DPA Counter Measure

In Versal devices, the AES engine has the capability of countermeasures, which means protection against DPA attacks. By default, the automotive devices (XA) include the DPA countermeasures. All other devices must be ordered with an ordering code to get DPA enabled devices.

As another counter measure against DPA attacks, boot images support key rolling to minimize the use of a single AES key. The DPA countermeasures can be used during boot as well as post-boot.

Key Sources

Red Key

The red key is stored as plain text in either BBRAM, eFUSEs, or the boot header.

Black Key

The black key is produced after the red key is encrypted using the PUF generated key encryption key (KEK).

Note: The KEK is unique per Versal device and cannot be read out of the device.

The black key can be stored in eFUSE, BBRAM, or in the boot header for secure boot. If encrypt-only boot mode is selected, the black key can only be stored in eFUSEs.

Note: The physical unclonable function (PUF) is only supported when using a nominal VCC_PMC of 0.70V. Refer to the *Versal ACAP Security Manual (UG1508)* in the Security Lounge (registration required) for detailed information on PUF usage.

User Key

After the boot process, you have the option to load the AES engine with the keys stored in BBRAM, eFUSES, as well as keys stored in memory that are specific to an operating system or an application.

Revocation

The Revocation ID points to an eFUSE and if the eFUSE is *not* programmed, then keys using that Revocation ID are valid. Programming the eFUSE revokes the key associated with its associated eFUSES. When revoking a key, it will also revoke an SPK because the Revocation ID is shared with the A-HWRoT boot mode.

Symmetric Hardware Root-of-Trust (S-HWRoT) Boot Mode (Encryption Required)

There are dedicated bits in eFUSES that correspond to the S-HWRoT boot mode. If any one of these bits are set, the S-HWRoT boot mode forces the device to only boot images that have the PLM and MetaHeader encrypted using a black (encrypted) eFUSE key. Encryption of partitions beyond the PLM and MetaHeader is defined by the MetaHeader which is authenticated using AES-GCM.

Versal ACAP Platform Management

The Versal™ ACAP is a heterogeneous multiprocessor SoC that combines multiple user programmable processors, FPGA, and advanced power management capabilities.

Modern power efficient designs require usage of complex system architectures with several hardware options to reduce power consumption, and usage of a specialized CPU to handle all power management requests coming from multiple masters to power on, power off resources, and handle power state transitions. In addition to power, there are other resources like clock, reset, and pins that need to be similarly managed. The challenge is to provide an intelligent software framework that complies to industry standard (IEEE P2415), and can handle all requests coming from multiple CPUs running different software. Xilinx® has created the platform management to support a flexible management control through the platform management controller (PMC).

The platform management handles several use case scenarios. For example, Linux provides basic power management capabilities, such as CPU frequency scaling, and CPU hot-plugging. The kernel relies on the underlining APIs to execute power management decisions, but most RTOS do not have this capability. Therefore, they rely on user implementation, which is made easier with use of the platform management framework.

Industrial applications, such as embedded vision, Advanced Driver Assistance, surveillance, portable medical, and Internet of Things (IoT) are increasing their demand for high-performance heterogeneous SoCs, but they have a tight power budget. Some of the applications are battery-operated, and battery life is a concern. Others, such as cloud and data center, have demanding cooling and energy costs, not including their need to reduce environmental cost. All these applications benefit from a flexible platform management solution.

Key Features

The following are the key features of the platform management:

- Provides centralized power state, clock, reset, and pin configuration information using the PMC
- Supports Embedded Energy Management Interface (EEMI) APIs (IEEE P2415)
- Provides support for the Linux common clock framework
- Provides support for the Linux reset framework
- Manages power state, clock, and reset of all devices

- Provides support for Linux power management including:
 - Linux device tree power management
 - ATF/PSCI power management support
 - CPU frequency scaling
 - CPU hot-plugging
 - Suspend
 - Resume
 - Wake-up process management
 - Idle
- Provides direct control of the following power management features with more than 24 APIs:
 - Core management
 - Error management
 - Memories and peripherals management
 - Power, clock, reset
 - Processor unit suspend or wake-up management

Versal ACAP Platform Management Overview

The Versal ACAP platform management implements the EEMI. Platform management allows software components running across different subsystems on Versal ACAP to issue or respond to platform management requests. The platform management also provides support through EEMI APIs to allow different processing units to configure clock characteristics, such as its enable/disable state, divisor, and the PLL to use. It also provides support through EEMI APIs for asserting/deasserting reset lines and configuring pins for use with different functional units.

Versal ACAP Power Domains

The Versal device is divided into following power domains:

- **Full power domain (FPD):** Contains the Arm® Cortex-A72 application processor unit (APU).
- **Low power domain (LPD):** Contains the Arm Cortex-R5F real-time processor unit (RPU), and on-chip peripherals.

- **System power domain (SPD):** Contains the DDR controllers and NoC.
- **PL power domain:** Contains the PL and the AI Engine.
- **Battery power domain:** Contains the real-time clock (RTC) as well as battery-backed RAM (BBRAM).
- **PMC power domain:** Contains the platform management controller.

The battery and PMC power domains are not managed by the framework. Designs that want to take advantage of the platform management switching the power domains, must keep some power rails discrete. This allows individual rails to be powered off with the power domain switching logic.

The following figure illustrates the Versal device power domains and islands.

Figure 30: Power Domains and Islands Diagram

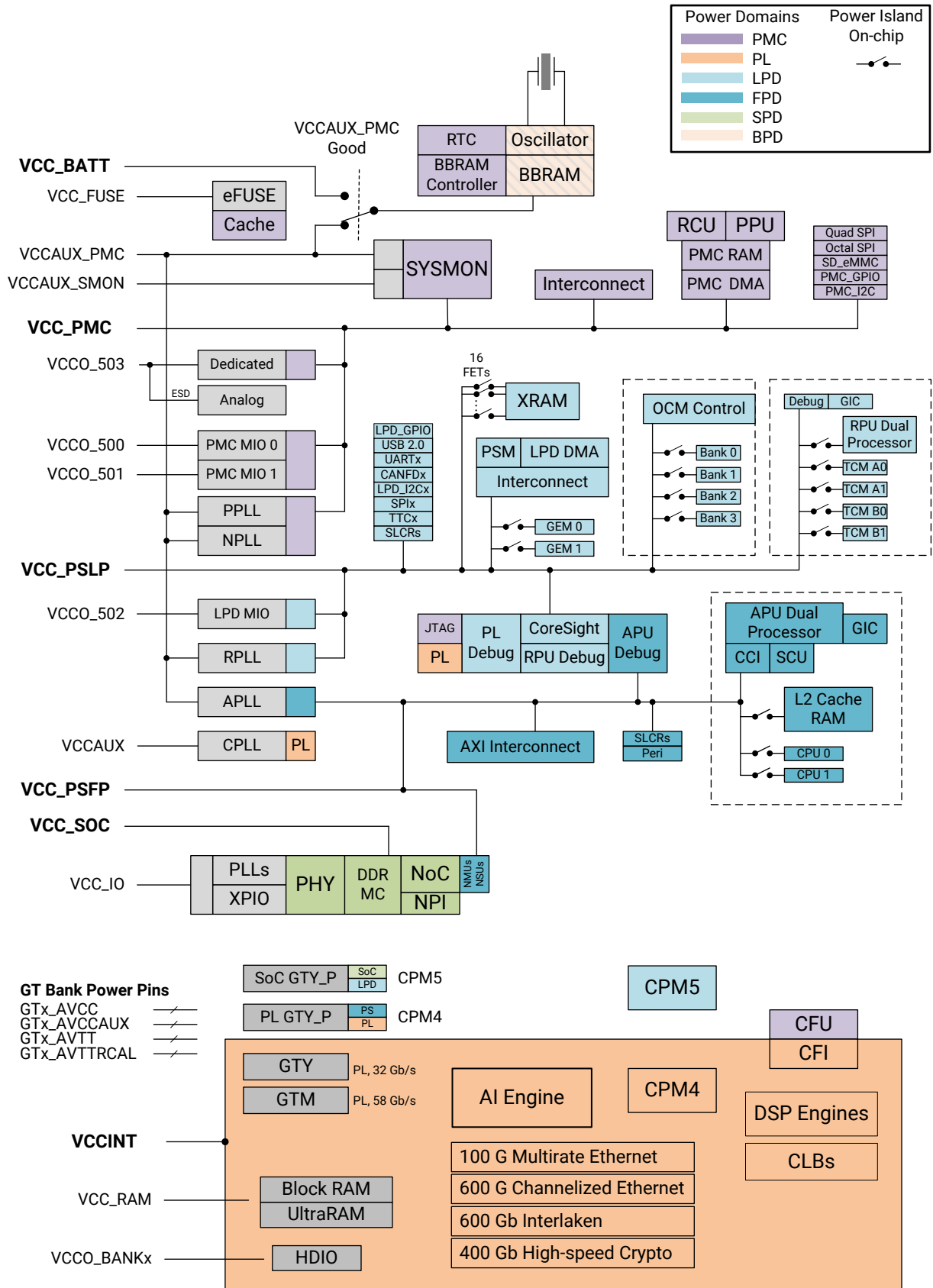

X23217-111820

Because of the heterogeneous multi-core architecture of the Versal ACAP, no processor can make autonomous decisions about power states of individual components or subsystems.

Instead, a collaborative approach is taken, where a power management API delegates all power management control to the platform management controller (PMC). The PMC is the key component in coordinating the power management requests received from the other processing units, such as the APU or the RPU, and the coordination and execution from other processing units through the power management API.

Versal ACAP also supports inter-processor interrupts (IPIs), which are used as the basis for platform management related communication between the different processors. For more information, refer to the interrupts information in the *Versal ACAP Technical Reference Manual (AM011)*.

Versal DFX Management

It is possible to configure the PL configuration at run time from baremetal and Linux-like operating systems. The PL configuration data for Versal ACAP can be accessed as PDI files. For baremetal/FreeRTOS applications, the “xilfpga” library can be utilized for programming the PL configuration data. For more details, see *OS and Libraries Document Collection (UG643)*. From Linux, the FPGA Manager in Versal ACAP provides an interface to download PL configuration data (DFX) at run time from Linux. This PL configuration data or DFX image is a PDI which can be either authenticated/encrypted or both or can be non-secure.

The following figure shows the FPGA programming flow for Linux.

Figure 31: FPGA Programming Flow from Linux

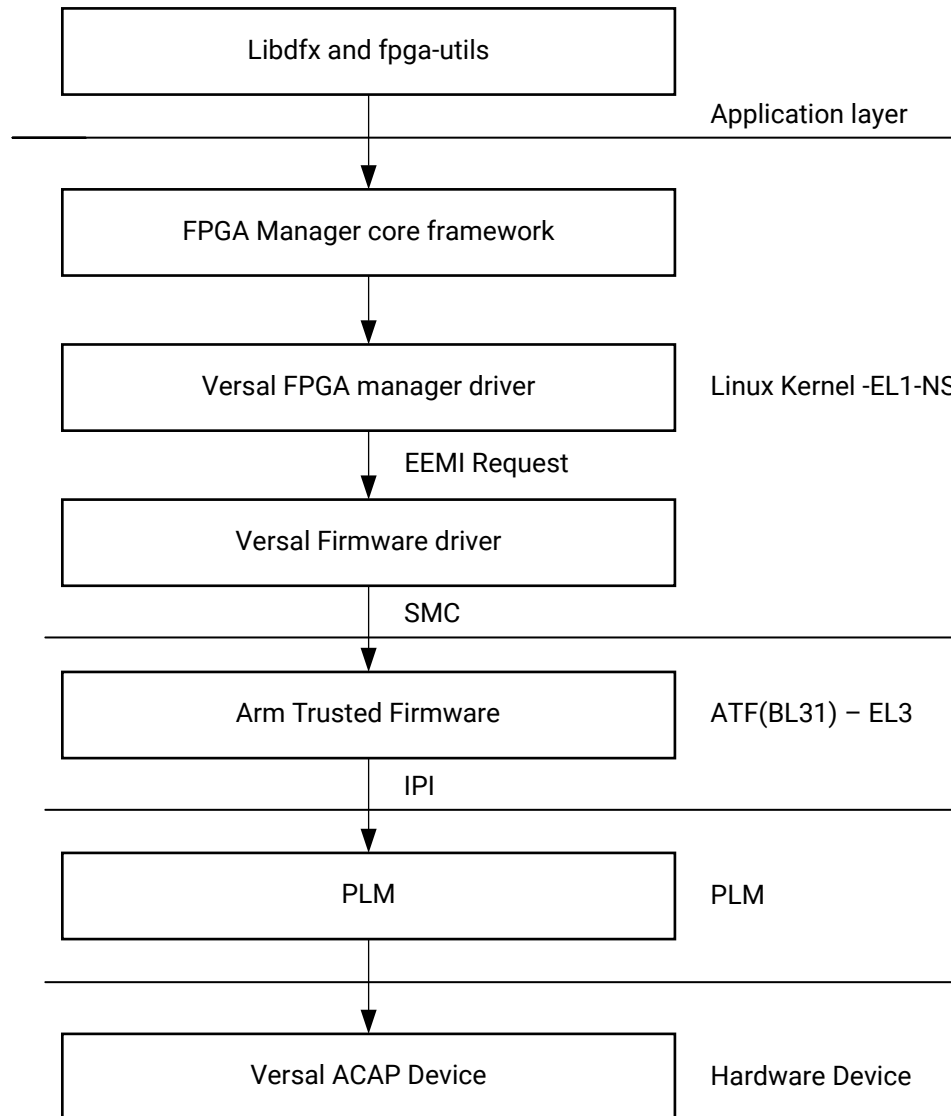

X25442-061121

To load a PL configuration data (PDI), the FPGA manager allocates the required memory and invokes the EEMI API using the FPGA LOAD API ID. This request is a blocking call. The FPGA manager waits for the response from the ATF and response is provided to the FPGA manager core layer which passes it to the application. At the application layer, Xilinx provides two user space utilities, namely fpgautils and libdfx for programming the PL configuration data.

fpgautils is a legacy and developer friendly Linux user space utility for programming the PL configuration data from command line. Unlike fpgautils, libdfx is a C library that can be integrated into user applications. It provides different APIs that can address multiple use cases for DFX or PL configuration data programming. It also provides faster programming capability by avoiding multiple buffer copies that are involved in other methods. For more information on libdfx and its usage, refer to the [libdfx repo](#). An example application for programming the PL configuration data is available in the `apps/` directory.

Versal ACAP Platform Management Software Architecture

The Versal ACAP architecture employs a dedicated programmable unit that controls the power-up, power-down, and monitors of all system resources. You benefit from a system that is better equipped on handling platform management administration for a multiprocessor heterogeneous system. However, the system becomes more complex to operate. The platform management framework abstracts this complexity and exposes only the APIs you need to meet your power budget and efficiently manage resources.

The PMC hardware/domain has two MicroBlaze units. The ROM Code Unit (RCU) is a MicroBlaze unit that runs the BootROM, while the processing unit (PPU) runs the PLM from the PPU RAM.

Outside of the two PMC domains, there is a PS LPD block and a domain processing system manager (PSM) MicroBlaze processor that is stored in the PSM RAM. The PSM is a MicroBlaze processor in the LPD domain that controls the power islands.

Based on CDOs passed to it, the PLM builds and adds a topology of resources to its platform management framework. The platform management framework manages resources such as power domains, power islands, clocks, resets, pins and their relationship to CPU cores, memory, and peripheral devices.

Figure 32: Platform Management Framework

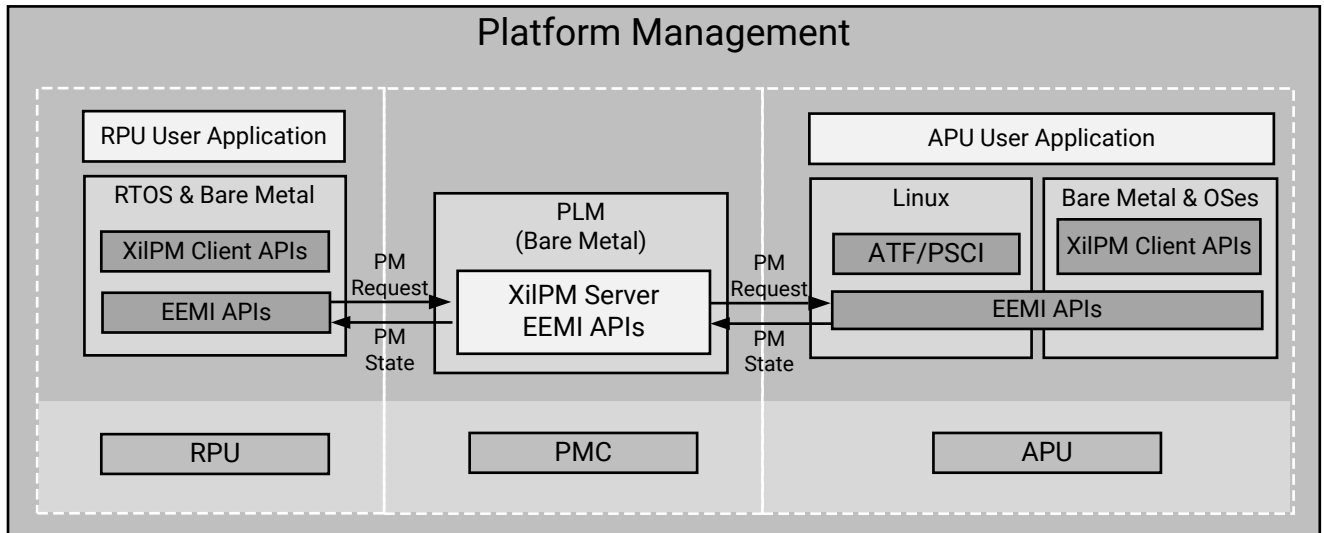

X23401-051220

The Versal ACAP platform management framework is based on an implementation of EEMI (refer to the *Embedded Energy Management Interface EEMI API Reference Guide* (UG1200)). APIs are available to the processing units to send messages to the PLM, as well as callback functions for the PLM to send messages to the processing units.

EEMI provides a common API that allows all software components to manage cores and peripherals. For power management, EEMI allows you to specify a high-level management goal, such as suspending a complex processor cluster or just a single core. The underlying implementation is then free to autonomously implement an optimal power-saving approach.

The Linux device tree provides a common description format for each device and its power characteristics. Linux also provides basic power management capabilities such as CPU and clock frequency scaling, and CPU hot-plugging. The kernel relies on the underlying APIs to execute power management decisions.

You can create your own platform management applications using the XilPM client library, which provides access to more than 24 APIs. The APIs can be grouped into the following functional categories:

- Slave device power management, such as memories and peripherals
- Clock management
- Reset management
- Pin management
- Miscellaneous

The following figure illustrates the API-based platform management software architecture.

Figure 33: API-Based Platform Management Software Architecture

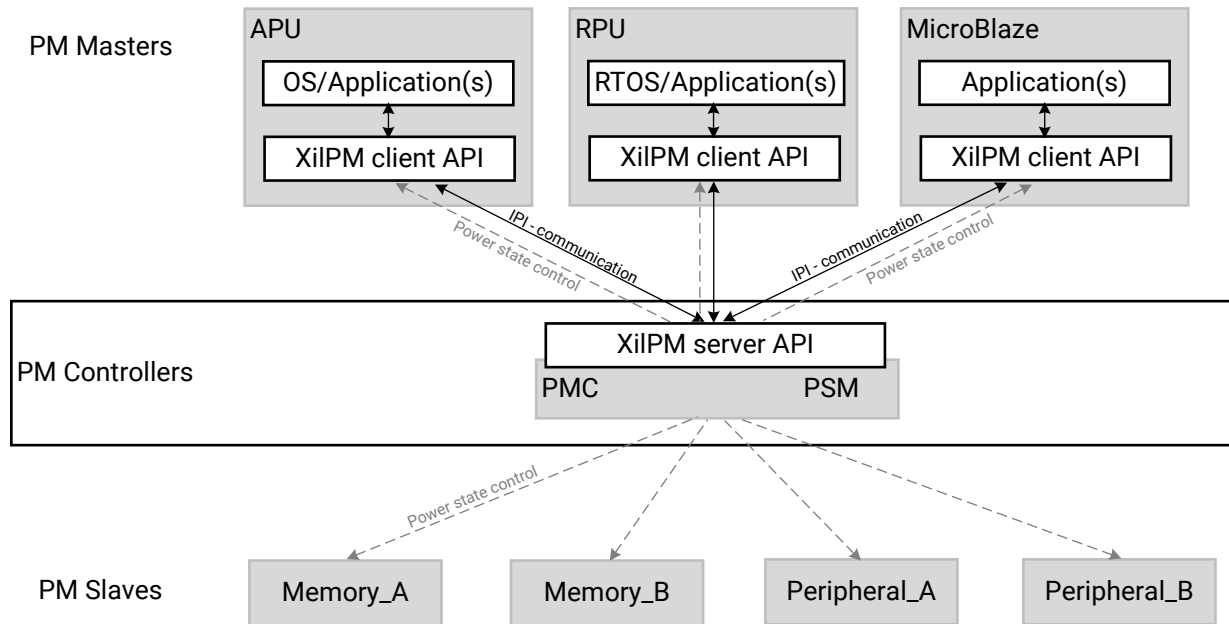

X23402-051821

Related Information

[Platform Loader and Manager](#)

API Calls and Responses

Platform Management Communication Using IPIs

In the Versal device, the platform management communication layer is implemented using inter-processor interrupts (IPIs), provided by the IPI block. For more details on IPIs, see the Interrupts chapter of the *Versal ACAP Technical Reference Manual* ([AM011](#)).

Each processing unit has a dedicated IPI channel with the PMC, consisting of an interrupt and a payload buffer. The buffer passes the API ID and up to five arguments. The IPI interrupt to the target triggers the following processing of the API:

- When calling an API function, a processing unit generates an IPI to the PMC, prompting the execution of necessary platform management action.
- The PMC performs each request atomically, meaning that the action cannot be interrupted.
- To support platform management callbacks, which are used for notifications from the PMC to a processing unit, each processing unit implements handling of these callback IPIs.

Platform Management Layers

The following API layers are included in the platform management implementation for the Versal devices:

- **XilPM (client):** Library layer used by standalone applications in the different processing units, such as the APU and RPU.
- **XilPM (server):** Library layer part of the PLM that handles the requests that are passed from the XilPM client layer through IPIs.
- **ATF:** The ATF contains its own implementation of the client-side PM framework. It is currently used by the Linux OS.
- **PLM:** The PLM receives IPI packets and passes platform management requests to the XilPM server.
- **PSM Firmware:** Invoked by the XilPM server to control power islands and power domains.

For more details on PMC, PSM, and power domain hardware topics, see the *Versal ACAP Technical Reference Manual (AM011)*.

The following figure shows the interaction between the APU, the RPU, and the platform management APIs.

Figure 34: API Layers Used Only With Bare-Metal Applications

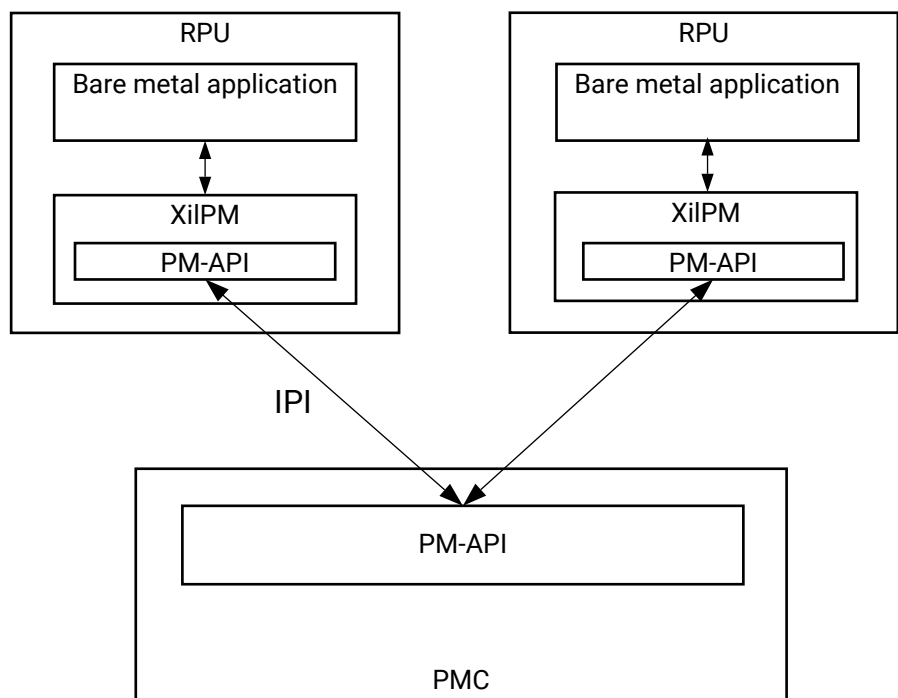

X23537-110520

If the APU runs a complete software stack with an operating system, it does not use the XilPM library. Instead, the ATF running at EL3 implements the client-side XilPM API and provides a secure monitor call (SMC)-based interface to the software running at EL2, SEL1, or EL1 depending on the Versal ACAP device system architecture.

For more details on the Armv8 architecture and its different execution modes, see <https://developer.arm.com/docs/ddi0487/latest/arm-architecture-reference-manual-armv8-for-armv8-a-architecture-profile>.

The following figure illustrates the platform management layers that are involved when running a full software stack on the APU.

Figure 35: Platform Management Layers Involved When Running a Full Software Stack on the APU

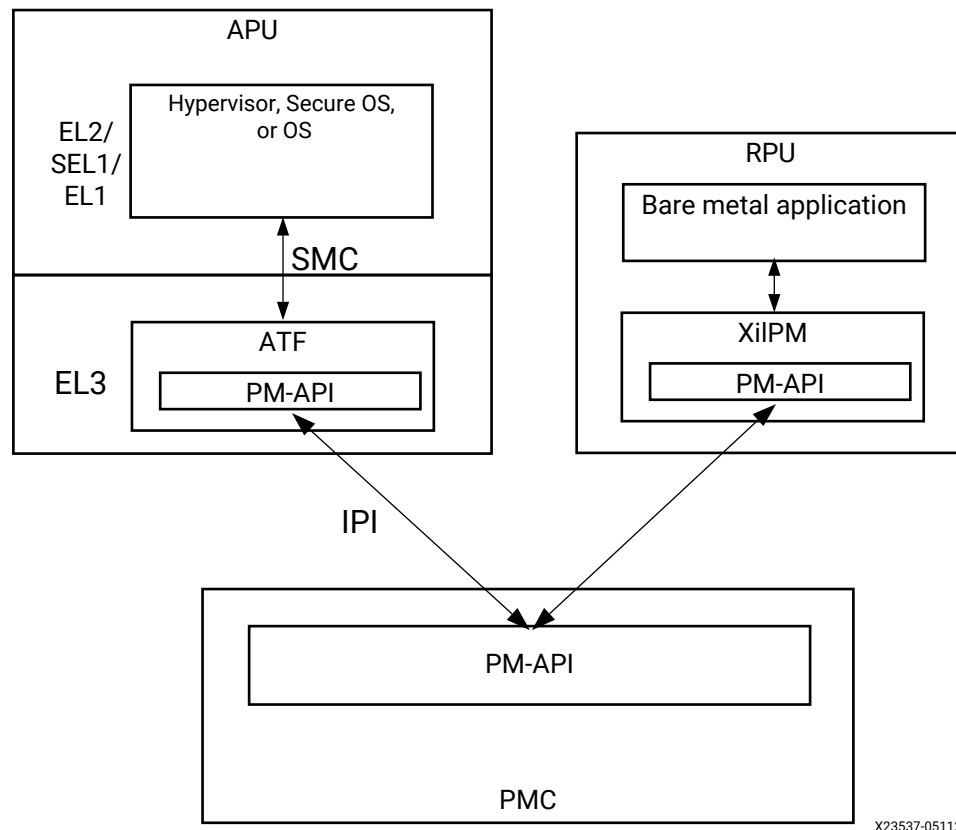

X23537-051120

Typical Platform Management API Call Flow

Any entity that is involved in power management is referred to as a node. The following sections describe how the platform management works with slave nodes allocated to each subsystem instead of the APU and the RPU.

Generally, the APU or the RPU inform the PMC about their usage of a slave node, by requesting for it. The PMC is then informed about the capability requirement needed from the slave node. At this point, the PMC powers up the slave node, so it can be initialized by the APU or the RPU.

Requesting and Releasing Slave Nodes

When a processing unit requires a peripheral or memory slave node, it must request the slave node using the power management API. After the slave node has performed its function and is no longer required, it can be released and powered off.

The following figure shows the call flow for a use case where the APU and the RPU are sharing an on-chip memory bank, `ocm0`.

Figure 36: Platform Management Framework Call Sequence for APU and RPU Sharing an On-Chip Memory Bank

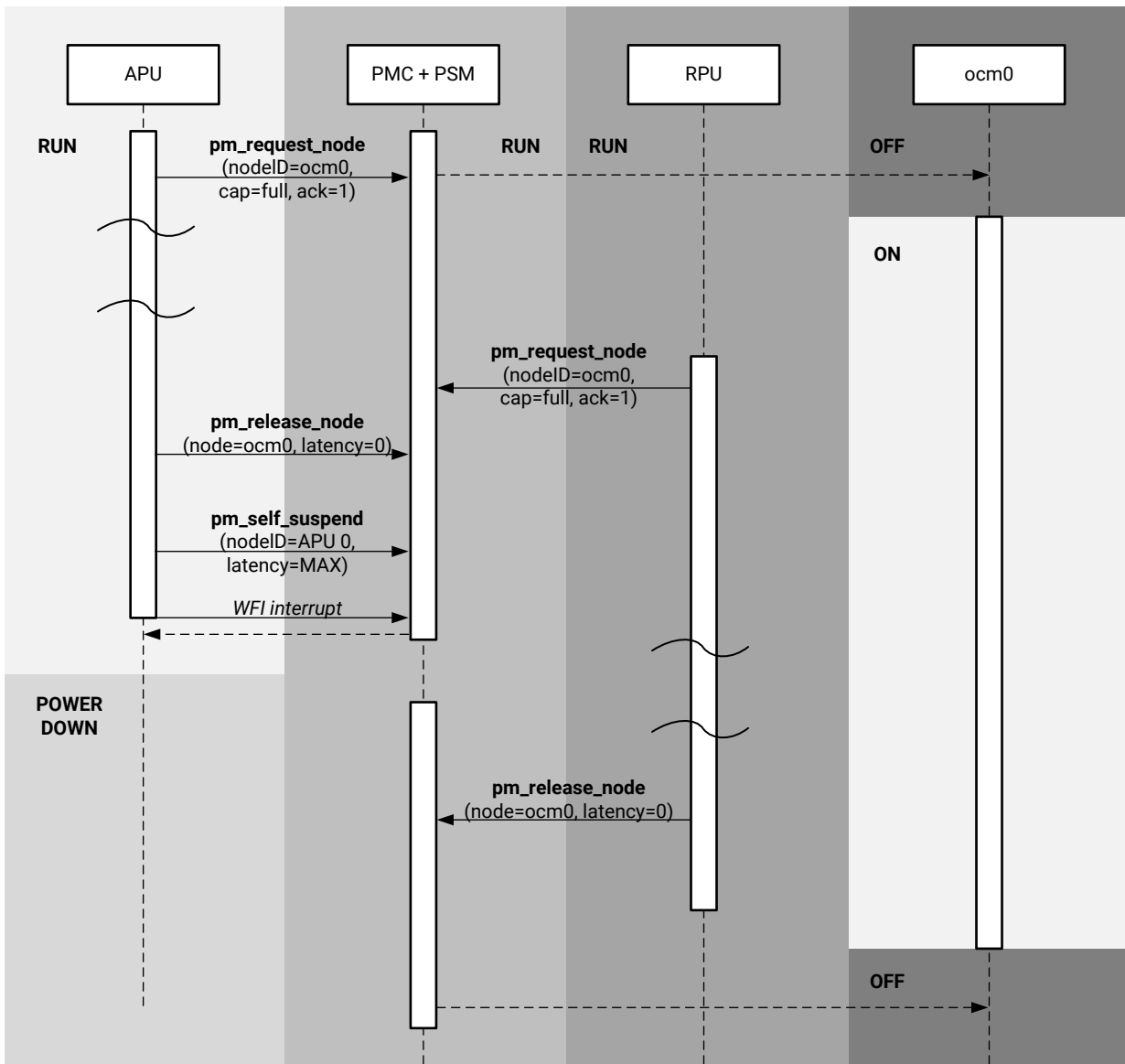

X20022-111020

Note: The `ocm0` memory remains powered on after the APU calls `XStatus XPm_ReleaseNode`, because the RPU has also requested the same slave node. After the RPU also releases the `ocm0` node, then the PMC requests the PSM to power off the `ocm0` memory.

Platform Management Default Subsystem

Currently, there is no support for isolation configuration, and all PM masters are part of the default subsystem.

In this configuration, both PM masters (APU and RPU) have permission to access all devices, so exercise caution on how PM slave devices are used by different masters.

Activation of Subsystem

To **activate a subsystem** is to make it operational by requesting (using `XPm_RequestNode`) all its pre-allocation devices. This is an essential one-time operation that is required before the subsystem image can start execution. Every time a subsystem is restarted/shutdown, activation happens before execution of the new subsystem image.

When the application binaries (ELFs) are downloaded using Programmable Device Image (PDI) as a subsystem image, the PLM automatically activates the corresponding subsystem image using the subsystem image ID that is present in the BIF. Currently, this is the default subsystem as there is no support for custom subsystems. However, there can be debugging use-cases where you need to download and execute application binaries (ELFs) directly on a master using the XSDB, and not through the PDI-flow. In such cases, the PLM is not aware of the corresponding subsystem image ID for ELFs. As a result, pre-allocation devices essential for a subsystem to be operational will not be requested, which may cause unforeseen issues. Therefore, before downloading any application binaries (ELFs) using XSDB, a one-time activation of a subsystem is required.

Currently, XSDB automatically requests the PLM to activate the default subsystem before downloading an application binary/ELF on a specific master. In future, when there are multiple/custom subsystems, you may need to explicitly activate the subsystem of choice for such debugging use-cases.

Using the API for Power Management

This section contains detailed instructions on how to use the Xilinx platform management APIs to carry out common power management tasks. These APIs can be used by any bare-metal application that imports the XilPM client library.

Implementing Power Management on a Processor Unit

The XilPM client library provides the functions that the standalone applications executing on a processor can use to initiate the power management API calls.

See *Zynq UltraScale+ MPSoC: Software Developers Guide* ([UG1137](#)) for information on how to include the XilPM library in a project.

Initializing the XilPM Library

Before initiating any power management API calls, you must initialize the XilPM library by calling the `XPm_InitXilpm` API. Because the argument to this API is a pointer to a proper IPI driver instance, there is a dependency for your design to have an IPI channel assigned to the PM master, so it could communicate with PMC.

For more information on IPs, see the Interrupts information in the *Versal ACAP Technical Reference Manual* ([AM011](#)).

For more information about `XPm_InitXilpm`, see *OS and Libraries Document Collection* ([UG643](#)).

Power Management Using `XPm_InitFinalize`

A subsystem sends the `XPm_InitFinalize(void)` requests the PLM to finalize the subsystem configuration and power down unused nodes to maintain optimum power consumption.

For bare-metal application, an application developer needs to call `XPm_InitFinalize(void)` from the application.

For Linux applications, the platform management driver calls `XPm_InitFinalize()`.

A subsystem that is incapable of PM never sends this request. Therefore, its platform management devices remain powered up at all times, or until the PM subsystem itself is powered down.

If `XPm_InitFinalize()` is not called, the PLM does not power down any device. The objective of `XPm_InitFinalize()` is to make the firmware aware that the caller subsystem of `XPm_InitFinalize()` is platform management capable (uses platform management APIs if it needs any device). `XPm_RequestNode()` will power up devices even if `XPm_InitFinalize()` is not invoked. Nodes will also be released through `XPm_ReleaseNode()` even if `XPm_InitFinalize()` is not invoked. `XPm_ReleaseNode()` also passes. However in this case, only the use count is decremented, and no power down operation is performed.

Pre-requisites for Power Management

Call `XPm_InitFinalize()` for proper power management and to obtain desired power values. The PLM power downs all unused nodes when you call `XPm_InitFinalize()` from each subsystem. The PLM also allows you to power down any device when you call the `XPm_ReleaseNode()` API. A PM-capable subsystem sends an `XPm_InitFinalize()` request after initializing the sub-system. The PLM then begins to power down the PM devices in this subsystem whenever they are not being used.

In a default subsystem (id = 0x1C000000), APU or RPU can exist in same subsystem (id = 0x1C000000). In such a case, if any of master calls `XPmInitFinalize()`, all unused nodes are powered down by the PLM. For example, if the APU is running Linux and it calls `XPmInitFinalize()` during the Linux boot from the Linux Power Management driver, unused devices will be powered down. If this default subsystem has any other processors, for example an RPU application, they must request device using `XPm_RequestNode()`. This is done to avoid powering down required nodes or request for nodes which are already powered down during initial boot sequence. For more details, see [Requesting and Releasing a Device From a Standalone Application](#).

Consider a APU subsystem that is PM capable (uses PM APIs), and a RPU subsystem that is PM incapable (does not use PM API). Assume that both subsystems use TCM.

As the APU subsystem is PM-capable, it calls both `XPm_RequestNode(TCM)` and `XPm_InitFinalize()`. The PLM then knows that the APU subsystem is PM capable, and calls `XPm_RequestNode()` when it requires a device.

In contrast, because the RPU is PM unaware, applications might be using devices without requesting the PM API, as Xilinx allows applications to run without using the XilPM library. The PLM is aware that the RPU subsystem is running, but remains unaware about the devices that are used by the RPU. Therefore, the PLM does not power down any device until each subsystem has called `XPm_InitFinalize()`.

Working with Slave Devices

The Versal ACAP platform management contains functions dedicated to managing slave devices (also referred to as PM slaves), such as memories and peripherals. Subsystems use these functions to inform the PMC about the requirements (such as capabilities and wake-up latencies) for those devices. The PMC manages the system so that each device resides in the lowest possible power state, meeting the requirements from all eligible subsystems.

Requesting and Releasing a Node

When a subsystem requires a device node, either peripheral or memory, the device must be requested using the power management API. After the device node has performed its function and is no longer required, it should be released, so the device can be powered off or used by other subsystems.

When you call the `XPm_InitFinalize()` API, the platform management firmware turns off devices (such as a peripheral or memory) that are not requested by any subsystem.

You must pass the `PM_CAP_ACCESS` argument to the `REQUEST_NODE` API to access the particular peripheral/memory, as otherwise it is not powered ON.

The device, clock, and the reset operation are also not allowed if the device is not requested.

Setting up Device Request Permissions

The PLM checks permissions for any subsystem that requests a device. While creating a subsystem in the Vivado tool, you can assign a single peripheral to multiple subsystems, or to a single subsystem. This information is exported to PMC CDO, and the access for requesting a device is allowed based on this information from the CDO. By default, this permission is shared for all subsystems, that is, a single device can be requested by multiple subsystems. The exceptions are clock, reset and the power operation that are allowed only if a single subsystem has requested any of these resources.

Note: All subsystems must call the `XPm_InitFinalize()` API when they have finished initializing all their devices and requested devices using `XPm_RequestNode()`. Otherwise, the PLM does not power down any device.

The following sequence is the ideal sequence for calling using the PM API for device management is as follows:

1. Call `XPm_RequestNode()` on all required devices.
2. Initialize devices.
3. Call `XPm_InitFinalize()` to inform PLM that all required devices are requested and initialized

It is not mandatory that `XPm_RequestNode()` has to be called before `XPm_InitFinalize()`. If `XPm_InitFinalize()` is called before `XPm_RequestNode()`, the PLM powers down that device (as initial state is ON). If `XPm_RequestNode()` is called after `XPm_InitFinalize()`, the PLM powers up the device.

Some device initialization is done through CDO. Therefore, if `XPm_InitFinalize()` is called before `XPm_RequestNode()`, it is possible that initialization is lost as device is powered down first and then powered up again. It is recommended that you call `XPm_InitFinalize()` once it has requested all required devices. Otherwise, you need to take care of initialization again.

When you call `XPm_ReleaseNode()`, be mindful that the device powers down, and initialization configuration might be lost.

Requesting and Releasing a Device From a Standalone Application

The application needs to call `XPm_RequestNode()` to request usage of peripheral/device. For example:

```
XStatus XPm_RequestNode (const u32 DeviceId, const u32 Capabilities, const
u32 QoS, const u32 Ack);
```

The arguments are as follows:

- **Device ID:** Device ID of the PM device to be requested.

- **Capabilities:** Device-specific capabilities are required, and can be combined. The capabilities include:
 - PM_CAP_ACCESS: Full access / functionality
 - PM_CAP_CONTEXT: Preserve context
 - PM_CAP_WAKEUP: Emit wake interrupts
 - PM_CAP_UNUSABLE: Runtime suspend (Device is requested for a subsystem but the device is clock disabled)
 - PM_CAP_SECURE: Secure access type (non-secure/secure)
 - PM_CAP_COHERENT: Device coherency
 - PM_CAP_VIRTUALIZED: Device virtualization

For more information, see *OS and Libraries Document Collection* ([UG643](#)).

- **QoS:** Quality of Service (0-100) is required.

Note: Currently, this argument is not available.

- **Ack:** Requested acknowledge type.

Note: This argument is used only for Zynq UltraScale+ MPSoCs. For Versal devices, this argument value is always set to blocking.

If a device is already requested by a subsystem, you can call `XPm_SetRequirement()` to change its requirement. For example:

```
XStatus XPm_SetRequirement (const u32 DeviceId, const u32 Capabilities,
const u32 QoS, const u32 Ack);
```

The application must release the device when it is no longer required. To release the device, call `XPm_ReleaseNode()`. For example:

```
XStatus XPm_ReleaseNode (const u32 DeviceId);
```

Changing Requirements

When a subsystem is using a PM slave, its requirement on the capability of the slave can change. For example, an interface port might go into a low power state, or even be completely powered off, if the interface is not being used. The subsystem can use `XPm_SetRequirement` to change the capability requirement of the PM slave. Typically, the subsystem would not release the PM slave if it will be changing the requirement again in the future.

The following example call changes the requirement for the node argument so it is powered up and accessible to the PM master.

```
XPm_SetRequirement(node, PM_CAP_ACCESS, 0, REQUEST_ACK_NO);
```

 **IMPORTANT!** *Setting the requirements of a node to zero is not equivalent to releasing the PM slave. By releasing the PM slave, a subsystem might be allowing other subsystems to use the device exclusively.*

When multiple subsystems share a PM slave (this applies mostly to memories), the PMC selects a power state of the PM slave that satisfies all requirements of the requesting subsystems.

The requirements on a PM slave include capability as well as latency requirements. Capability requirements may include a top capability state, some intermediate capability states, an inactive state (but with the configuration retained), and the off state. Latency requirement specifies the maximum time allowed for the PM slave to switch to the top capability state from any other state. If this time limit cannot be met, the PMC will leave the PM slave in the top capability state regardless of other capability requirements.

For more information about `XPm_SetRequirement`, see *OS and Libraries Document Collection (UG643)*.

Self-Suspending

A processing unit can be a cluster of CPUs. The APU is a dual-core Arm Cortex-A72 CPU and RPU a dual-core Arm Cortex-R5F CPU. The RPUs can run independently (split mode) or in fault tolerant mode (lockstep). Currently, these processing units are part of the Default Subsystem.

Any processing unit can suspend itself by calling the `XPm_SelfSuspend` API to inform PMC about its intent. The processing unit must also inform the target state as part of this call. Currently, CPU Idle target state is supported for PU Suspend.

There are two types of target states CPU Idle and Suspend to RAM.

Actions performed by the respective processing units, PMC and PSM are discussed as follows in each case.

- **CPU Idle:**
 - Rich OS-like Linux has the capability to idle and subsequently power-down cores not being used by any process. This helps in power saving. If the workload increases, the OS can also wake up the powered down core. The platform management provides API calls as part of ATF and the XilPM (Client) library.
 - A processing unit can invoke CPU Idle in a bare-metal APU application use case by using `XPm_SelfSuspend` with the target state set as `PM_SUSPEND_STATE_CPU_IDLE`.
- **Suspend to RAM:**
 - The platform management provides the capability to suspend an entire subsystem. If the subsystem uses DDR and no other subsystem uses DDR, XilPM puts the DDR into Self-Refresh mode. This mode eliminates need for the DDRMC to refresh the DRAM.
 - A PM master that is part of subsystem (to be suspended) can invoke subsystem suspend using the `XPm_SelfSuspend` call to the PMC by setting target state as `PM_SUSPEND_STATE_SUSPEND_TO_RAM`.

For more information about `XPm_SelfSuspend` and `XPm_SuspendFinalize`, see *OS and Libraries Document Collection* ([UG643](#)).

Setting a Wake-up Source

The platform management provides the option to power down a PU or a subsystem. The platform management can even power down the entire FPD if none of the FPD devices are in use and existing latency requirements allow this. If the FPD is powered off and the APU is woken up by an interrupt triggered by a device in the LPD or PMC domain, the GIC Proxy must be configured to allow propagation of FPD wake events. The APU can ensure this by calling `XPm_SetWakeUpSource` for all devices that might need to issue wake interrupts.

Before suspending, the PU must call the `XPm_SetWakeUpSource` API and add the slaves as a wake-up source. The PU can then set requirement to zero. However, to set the requirement to zero, the following conditions should be met:

1. No other subsystem can share the devices. In the present case, because only default subsystem is supported, this is not a consideration.
2. No other PM master (that is in Running state) present in the same subsystem, as the PU that is self suspending should use the slave device.

Setting the requirement to zero indicates to the platform management that the subsystem does not require these slaves to be up. After the PU finalizes the suspend procedure, provided no devices under FPD are being used, the PMC powers the entire FPD and configures the GIC proxy to enable propagation of the wake event of the LPD or PMC domain slaves.

For more information about `XPm_SetWakeupSource`, see *OS and Libraries Document Collection* ([UG643](#)).

Resuming Execution

A CPU can be woken up by:

- Wake interrupt triggered by a hardware resource
- Explicit wake request using the `XPm_RequestWakeup` client API

The CPU starts executing from the resume address provided with the `XPm_SelfSuspend` call.

For more information about `XPm_RequestWakeup` and `XPm_SelfSuspend`, see *OS and Libraries Document Collection* ([UG643](#)).

Suspend-Resume Flow

The following figure shows the detailed interactions between different processors for a suspend resume use case.

Figure 37: Versal ACAP APU Suspend/Resume Flow

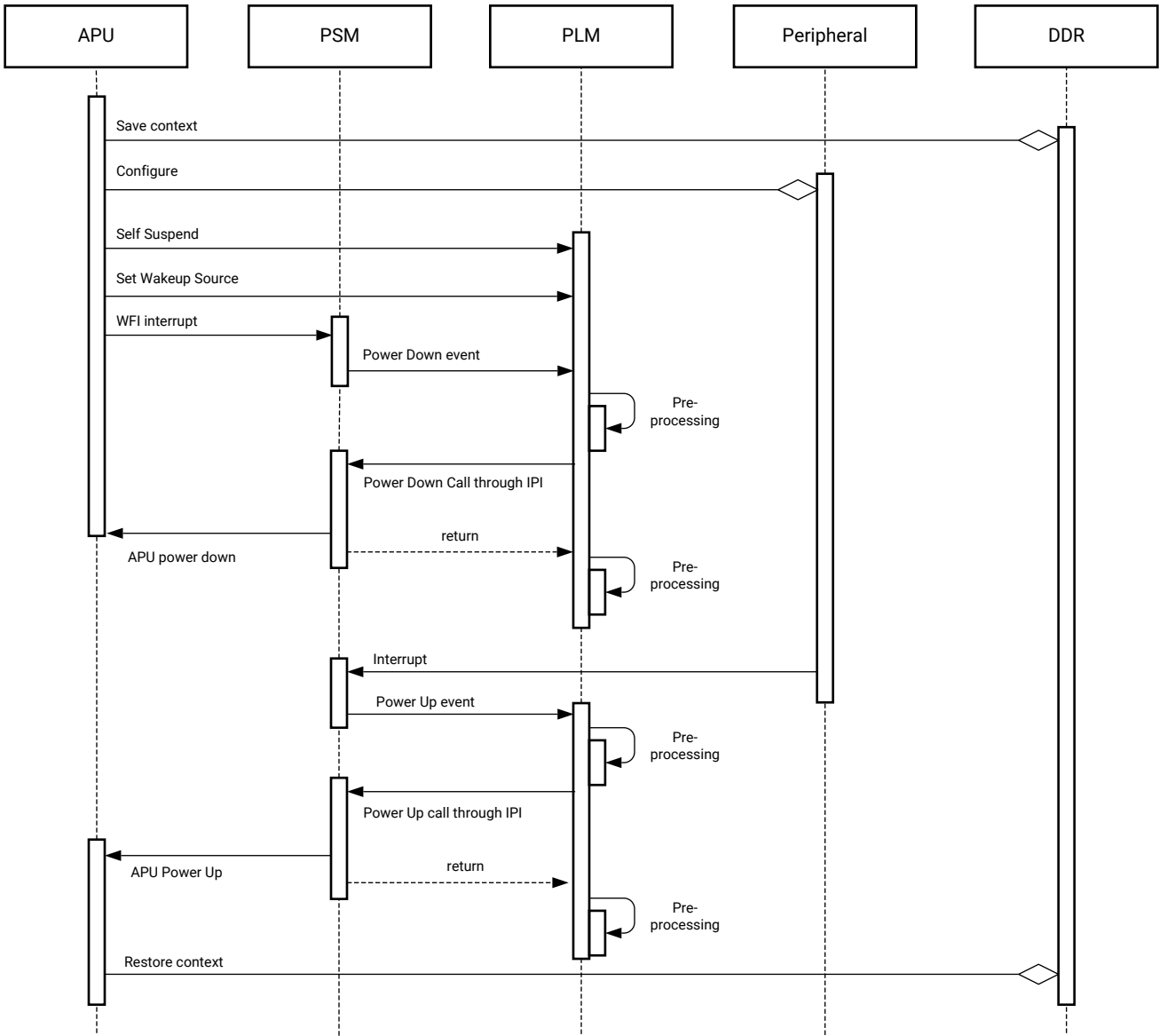

X23866-051220

In this example, a peripheral is set up as a wake up source. Each step is explained as follows:

- **Suspend Flow:**

1. APU saves the CPU context in DDR.
2. Peripheral is configured to be used as a wake up source
3. APU through ATF or XilPM client (if APU bare-metal application is running) informs PMC of its intent to suspend. PLM enables WFI interrupt.
4. Informs PLM of the Wake Up Source.

5. APU interrupts PSM by going into WFI state. If APU runs a bare-metal application, PSM can be interrupted by using `XPm_SuspendFinalize` API.
 6. After receiving the interrupt, a handshake between PSM and PLM occurs through the IPI. PSM powers down by power implementing power gating, asserting reset to APU and clock gating APU.
- **Wake Up Flow:**
 1. The peripheral (configured by the APU to act as a wake up source) interrupts PSM.
 2. PSM handshakes with PLM to initiate APU power up.
 3. After the handshake, PSM powers up the APU. It disables power gating, deassert reset, and disables clock gating on the APU.
 4. APU resumes context stored in the DDR.

Suspending the Entire FPD Domain

To power-down the entire full power domain, the PMC must suspend the APU when none of the FPD devices are in use. After this condition is met, the PMC can power-down the FPD automatically. The PMC powers down the FPD if no latency requirements constrain this action, otherwise the FPD remains powered on.

For information on powering down the FPD, refer to `Suspend to RAM` in [Self-Suspending](#).

Forcefully Powering Down the FPD

There is the option to force the FPD to power-down by calling the function `XPm_ForcePowerdown`. This requires that the requesting PU has proper privileges configured in the PMC. The PMC releases all PM Slaves used by the APU automatically.



IMPORTANT! *This force method is typically not recommended, especially when running complex operating systems on the APU because it could result in loss of data or system corruption, due to the OS not suspending itself gracefully.*

For more information about `XPm_ForcePowerdown`, see *OS and Libraries Document Collection (UG643)*.

Using the API for Clock Management

There are EEMI APIs available that allow processing units to manage clocks in the system. Each clock is identified by a unique `ClockId`. A PM master can use the `XPm_Query` API to obtain a list of `ClockIds` accessible to that processing unit. Before a PM master can modify any attributes of a clock, the master should request the slave device that is associated with that clock. See the `XPm_RequestNode` API in *OS and Libraries Document Collection (UG643)* for more information.

Use the following APIs to get and set a clock's state:

- `XStatus XPm_ClockGetStatus(const u32 ClockId, u32 *const State)`
- `XStatus XPm_ClockEnable(const u32 ClockId)`
- `XStatus XPm_ClockDisable(const u32 ClockId)`

Use the following APIs to configure a clock to operate at a different divider value:

- `XStatus XPm_ClockGetDivider(const u32 ClockId, u32 *const Divider)`
- `XStatus XPm_ClockSetDivider(const u32 ClockId, const u32 Divider)`

Use the following APIs to configure clocks that could be driven by different parents:

- `XStatus XPm_ClockGetParent(const u32 ClockId, u32 *const ParentId)`
- `XStatus XPm_ClockSetParent(const u32 ClockId, const u32 ParentId)`



IMPORTANT! *ParentId is an index to possible clocks that could be configured as a parent of ClockId. In Zynq UltraScale+ MPSoC, the definition of ParentId is not unified between Linux and standalone applications. In Versal ACAP, these EEMI APIs are unified in expecting ParentId to be an index value to possible parent clocks.*

Use the following APIs to configure the rate of reference clocks:

- `int XPm_ClockGetRate(const u32 ClockId, u32 *const Rate)`
- `int XPm_ClockSetRate(const u32 ClockId, const u32 Rate)`



IMPORTANT! *XPm_ClockSetRate() can only be valid during CDO loading. You cannot set the clock rate from XilPM client API.*

Use the following APIs to configure PLLs that are identified by ClockId:

- `XStatus XPm_PllGetMode(const u32 ClockId, u32 *const Value)`
- `XStatus XPm_PllSetMode(const u32 ClockId, const u32 Value)`
- `XStatus XPm_PllGetParameter(const u32 ClockId, const enum XPm_PllConfigParams ParamId, u32 *const Value)`
- `XStatus XPm_PllSetParameter(const u32 ClockId, const enum XPm_PllConfigParams ParamId, const u32 Value)`

See *OS and Libraries Document Collection* ([UG643](#)) for more information about these APIs.

Using the API for Reset Management

There are EEMI APIs available which allow PUs to manage reset lines in the system. Each reset is identified by a unique `ResetId`. In case of Linux as a PM master, a set of available `ResetIds` are obtained from the device tree. Before a PM master can modify state of a reset line, it should request the slave device that is associated with that reset. See the `XPm_RequestNode` API in *OS and Libraries Document Collection* ([UG643](#)) for more information.

Use the following APIs to manage resets:

- `XStatus XPm_ResetGetStatus(const u32 ResetId, u32 *const State)`
 - State is either 1 (asserted), or 2 (released)
- `XStatus XPm_ResetAssert(const u32 ResetId, const u32 Action)`
 - Action is either 0 (reset_release), 1 (reset_assert), or 2 (reset_pulse)

Using the API for Pin Management

There are EEMI APIs available that allow PUs to manage pins in the system. Each pin is identified by a unique `PinId`. A PM master could obtain a list of `PinIds` accessible to that PU by using the `XPm_Query` API.

Use the following APIs to request or release control of a pin:

- `XStatus XPm_PinCtrlRequest(const u32 PinId)`
- `XStatus XPm_PinCtrlRelease(const u32 PinId)`

You can configure a pin for use by different functional units. Use the `XPm_Query` API to obtain a list of functional units accessible to a pin, which is identified by `FunctionId`. Request a pin before assigning a functional unit to a pin. Most functional units are associated with a device. Use the `XPm_RequestNode` API to request the device before assigning it to a pin.

- `XStatus XPm_PinCtrlGetFunction(const u32 PinId, u32 *const FunctionId)`
- `XStatus XPm_PinCtrlSetFunction(const u32 PinId, const u32 FunctionId)`

Use the following APIs to configure a pin for different operating characteristics. For a list of possible `ParamIds` and `ParamVals`, see *OS and Libraries Document Collection* ([UG643](#)).

- `XStatus XPm_PinCtrlGetParameter(const u32 PinId, const u32 ParamId, u32 *const ParamVal)`
- `XStatus XPm_PinCtrlSetParameter(const u32 PinId, const u32 ParamId, const u32 ParamVal)`

Using Miscellaneous APIs

Most of Platform Management APIs can be categorized into groups like clock management, pin management, and device management. However, there are few APIs which do not belong in any specific group. These APIs are considered as Miscellaneous APIs. They include:

- Device control inferences
- General Storage Registers access
- Query information
- Event notifications
- Subsystem Activation

The following sections describe these APIs in detail.

XPm_DevIoctl EEMI API

The `XPm_DevIoctl EEMI` API allows a platform management master to perform specific operations to certain devices.

The following table lists the supported operations in Versal ACAP.

Table 35: XPm_DevIoctl Operations

ID	Name	Description	Arguments			
			Node ID	Arg1	Arg2	Return Value
0	IOCTL_GET_RPU_OPER_MODE	Returns current RPU operating mode	NODE_RPU_0 NODE_RPU_1	-	-	Operating mode: 0: LOCKSTEP 1: SPLIT
1	IOCTL_SET_RPU_OPER_MODE	Configures RPU operating mode	NODE_RPU_0 NODE_RPU_1	Value of operating mode 0: LOCKSTEP 1: SPLIT	-	-
2	IOCTL_RPU_BOOT_ADDR_CONFIG	Configures RPU boot address	NODE_RPU_0 NODE_RPU_1	Value to set for boot address 0: LOVEC/TCM 1: HIVEC/OCM	-	-
3	IOCTL_TCM_COMB_CONFIG	Configures TCM to be in split mode or combined mode	NODE_RPU_0 NODE_RPU_1	Value to set (Split/Combined) 0: SPLIT 1: COMB	-	-

Table 35: Xpm_DeVioctl Operations (cont'd)

ID	Name	Description	Arguments			
			Node ID	Arg1	Arg2	Return Value
4	IOCTL_SET_TAPDELAY_BYPASS	Enable/disable tap delay bypass	NODE_QSPI	Type of tap delay 2: QSPI	Tapdelay Enable/Disable 0: DISABLE 1: ENABLE	-
6	IOCTL_SD_DLL_RESET	Resets DLL logic for the SD device	NODE_SD_0, NODE_SD_1	SD DLL Reset type 0: ASSERT 1: RELEASE 2: PULSE	-	-
7	IOCTL_SET_SD_TAPDELAY	Sets input/output tap delay for the SD device	NODE_SD_0, NODE_SD_1	Type of tap delay to set 0: INPUT 1: OUTPUT	Value to set for the tap delay	-
12	IOCTL_WRITE_GGS	Writes value to GGS register	-	GGS register index (0/1/2/3)	Register value to be written	-
13	IOCTL_READ_GGS	Returns GGS register value	-	GGS register index (0/1/2/3)	-	Register value
14	IOCTL_WRITE_PGGS	Writes value to PGGS register	-	PGGS register index (0/1/2/3)	Register value to be written	-
15	IOCTL_READ_PGGS	Returns PGGS register value	-	PGGS register index (0/1/2/3)	-	Register value
17	IOCTL_SET_BOOT_HEALTH_STATUS	Sets healthy bit value to indicate boot health status to firmware	-	healthy bit value	-	-

Table 35: XPm_DevIoctl Operations (cont'd)

ID	Name	Description	Arguments			
			Node ID	Arg1	Arg2	Return Value
19	IOCTL_PROBE_COUNTER_READ	Read probe counter register of LPD/FPD	FPD/LPD power domain ID 0x4210002U for LPD 0x420C003U for FPD	Register configuration - Counter Number (0 to 7 bit) - Register Type (8 to 15 bit) 0 - LAR_LSR access (Request Type and Counter Number are ignored) 1 - Main Ctl (Counter Number is ignored) 2 - Config Ctl (Counter Number is ignored) 3 - State Period (Counter Number is ignored) 4 - PortSel 5 - Src 6 - Val - Request Type (16 to 23 bit) 0 - Read Request 1 - Read Response 2 - Write Request 3 - Write Response 4 - LPD Read Request (For LPD only) 5 - LPD Read Response (For LPD only) 6 - LPD Write Request (For LPD only) 7 - LPD Write Response (For LPD only)	-	Register value

Table 35: XPm_DevIoctl Operations (cont'd)

ID	Name	Description	Arguments			
			Node ID	Arg1	Arg2	Return Value
20	IOCTL_PROBE_COUNTER_WRITE	Write probe counter register of LPD/FPD	FPD/LPD power domain ID 0x4210002U for LPD 0x420C003U for FPD	Register configuration - Counter Number (0 to 7 bit) - Register Type (8 to 15 bit) 0 - LAR_LSR access (Request Type and Counter Number are ignored) 1 - Main Ctl (Counter Number is ignored) 2 - Config Ctl (Counter Number is ignored) 3 - State Period (Counter Number is ignored) 4 - PortSel 5 - Src - Request Type (16 to 23 bit) 0 - Read Request 1 - Read Response 2 - Write Request 3 - Write Response 4 - LPD Read Request (For LPD only) 5 - LPD Read Response (For LPD only) 6 - LPD Write Request (For LPD only) 7 - LPD Write Response (For LPD only)	Register value to be written	-

Table 35: XPm_DevIoctl Operations (cont'd)

ID	Name	Description	Arguments			
			Node ID	Arg1	Arg2	Return Value
21	IOCTL_OSPI_MUX_SELECT	Select OSPI AXI Multiplexer	NODE_OSPI	Operation mode 0: Select DMA 1: Select Linear 2: Get mode	-	Get mode 0: DMA 1: Linear
22	IOCTL_USB_SET_STATE	Set USB controller in different device power states	NODE_USB_0	Requested power state 0: D0 1: D1 2: D2 3: D3	-	-
23	IOCTL_GET_LAST_RESET_REASON	Get last reset reason of system	-	-	-	0 - The POR button was pressed outside of the system 1 - An internal POR was caused by software 2 - One of the other SSIT slices caused a POR 3 - An error caused a POR 7 - JTAG TAP initiated system reset 8 - Error initiated system reset 9 - Software initiated system reset 10 - One of the other SSIT slices caused a system reset 15 - Invalid reset reason

Table 35: XPm_DevIoctl Operations (cont'd)

ID	Name	Description	Arguments			
			Node ID	Arg1	Arg2	Return Value
24	IOCTL_AIE_ISR_CLEAR	Clear AIE NPI Interrupts	DEV_AIE (0x18224072 U)	4-bit NPI Interrupt Clear Mask (wtc) Bit<3-0> correspond to Interrupt<3-0>	-	-

XPm_GetOpCharacteristic EEMI API

The XPm_GetOpCharacteristic EEMI API allows a PM master to request PMC to return information about an operating characteristic of a component. Currently, the following device characteristics can be requested:

- Temperature of the SoC
- Wake-up latency of Cores, Power Islands and rails, and PLL locking time

XPm_Query EEMI API

The XPm_Query EEMI API allows a platform management master to request specific configuration information from the PLM.

The following table lists the supported operations in Versal™ ACAP.

Table 36: XPm_Query Operations

ID	Name	Description	Arguments		
			Arg1	Arg2	Return Value
1	XPM_QID_CLOCK_GET_NAME	Get the string name associated with a clock id	Clock id	-	Data[0]: Success/Failure Data[1-4]: String name
2	XPM_QID_CLOCK_GET_TOPOLOGY	Get a clock's topology	Clock id	Topology node index	Data[0]: Success/Failure Data[1-3]: 3 nodes of topology start from node index (passed in Arg 2)

Table 36: XPm_Query Operations (cont'd)

ID	Name	Description	Arguments		
			Arg1	Arg2	Return Value
3	XPM_QID_CLOCK_GET_FIXEDFACTOR_PARAMS	Get Fixed Factor value	Clock id	-	Data[0]: Success/Failure Data[1]: Fixed factor value
4	XPM_QID_CLOCK_GET_MUXSOURCES	Get clock's multiplexer sources	Clock id	Parent node index	Data[0]: Success/Failure Data[1-3]: Parents id of a clock, starts from parent index (passed in Arg 2)
5	XPM_QID_CLOCK_GET_ATTRIBUTES	Get clock's attributes	Clock id	-	Data[0]: Success/Failure Data[1] Bit(0): Valid/Invalid clock Data[1] Bit(1): Initial enable requirement Data[1] Bit(2): Clock type (output/external) Data[1] Bit(14:19): Clock node type Data[1] Bit(20-25): Clock node subclass Data[1] Bit(26:31): Clock node class
6	XPM_QID_PINCTRL_GET_NUM_PINS	Get the number of pins available for configuration	-	-	Data[0]: Success/Failure Data[1]: Number of pins

Table 36: XPm_Query Operations (cont'd)

ID	Name	Description	Arguments		
			Arg1	Arg2	Return Value
7	XPM_QID_PINCTRL_GET_NUM_FUNCTIONS	Get the total number of functional units available	-	-	Data[0]: Success/Failure Data[1]: Number of functions
8	XPM_QID_PINCTRL_GET_NUM_FUNCTION_GROUPS	Get the number of groups that a function id belongs	Function id	-	Data[0]: Success/Failure Data[1]: Number of groups
9	XPM_QID_PINCTRL_GET_FUNCTION_NAME	Get the string name associated with a functional unit	Function id	-	Data[0]: Success/Failure Data[1-3]: String name
10	XPM_QID_PINCTRL_GET_FUNCTION_GROUPS	Get group ids that a function id belongs	Function id	Index	Data[0]: Success/Failure Data[1-3]: 6 groups start from index (Arg2), each group is of 16 bits
11	XPM_QID_PINCTRL_GET_PIN_GROUPS	Get group ids that a pin id could belong	Pin id	Index	Data[0]: Success/Failure Data[1-3]: 6 groups start from index (Arg 2), each group is of 16-bits
12	XPM_QID_CLOCK_GET_NUM_CLOCKS	Get the number of clocks	-	-	Data[0]: Success/Failure Data[1]: Number of clocks

Table 36: XPm_Query Operations (cont'd)

ID	Name	Description	Arguments		
			Arg1	Arg2	Return Value
13	XPM_QID_CLOCK_GET_MAX_DIVISOR	Get the maximum divisor value of a clock	Clock id	-	Data[0]: Success/Failure Data[1]: Maximum divisor value
14	XPM_QID_PLD_GET_PARENT	Get the parent of the PL Device Node	PLDevice Id	-	Data[0]: Success/Failure Data[1]: PLDevice Parent

XPm_ActivateSubsystem API

The XPm_ActivateSubsystem API allows the XSDB master to request PMC to activate a subsystem. See [Activation of Subsystem](#) for more details.

This API activates a subsystem by requesting all its pre-allocation devices that are essential for it to be operational. This API accepts a target subsystem ID that needs activation, as an input argument. The format for activating a subsystem is as follows:

```
XPm_ActivateSubsystem(u32 Subsystem ID)
```

This command is only allowed from the XSDB master. Currently, only the default subsystem is supported and is automatically activated before downloading any application binaries on a specific master.

Event Management Framework

The Event Management Framework allows a PU to request the PMC to call its notify callback whenever a qualifying event occurs. One can request to be notified for a specific node or any event related to a specific node. The two qualifying events will cause the invocation of the callback function gets called for below events:

- State change of the node for which callback is registered
- Zero users of the node for which callback is registered
- Error events for which callback is registered

If you are no longer interested in receiving notifications about events related to the node that the callback was previously requested, you can de-register it.

Note: Only the error, device, and power nodes are supported in this release.

For a complete list of the available error events, refer to the *Versal ACAP Technical Reference Manual* ([AM011](#)).

Event Management in Standalone Application

For Standalone application agent needs to use `XPm_Register_Notifier ()` of XilPM Client Lib to gets notify for any specific event(s). If an agent is no longer interested in receiving notification about events related to the node that the callback was previously registered, use `XPm_Register_Notifier ()` for de-registration.

The caller shall initialize the notifier object before invoking the `XPm_RegisterNotifier()` with the following parameters.

- **NodeID:** ID of the node to be notified about.
- **eventId:** ID of the event in question, events (EVENT_STATE_CHANGE, EVENT_ZERO_USERS, EVENT_ERROR_MASK)
- **wake: true::** wake up on event, false: do not wake up (only notify if awake), no buffering/queuing
- **callback:** Pointer to the custom callback function to be called when the notification is available. The callback executes from interrupt context, so you must take special care when implementing the callback. Callback is optional, may be set to NULL.

In case of when any event occurred, the agent will get data in the following format as payload.

Reserved [12-15]	Event Mask [8-11]	NodeID [4-7]	Callback Type [0-3]
Node state [12-15]	Event ID [8-11]	NodeID [4-7]	Callback Type [0-3]

Once the agent catches the notification check for the Callback type. In case of call back type is `PM_NOTIFY_CB`, agent needs to call `XPm_NotifyCb()`.

For more information, refer to the *OS and Libraries Document Collection* ([UG643](#)).

Registering and Unregistering the Event Handler

To register and unregister the event handler, follow these steps:

1. Define callback function wants to call on occurrence of event.

```
void TestNotifyCb(XPm_Notifier* const notifier)
{
    xil_printf("Received notification: Node=0x%x, Event=%d, OPP=%d\n",
               notifier->node, (int)notifier->event, (int)notifier->oppoint);
}
```

2. Define the Notifier Object

```
XPm_Notifier notifier = {
    .callback = TestNotifyCb,
    .node = PM_DEV_USB_0,
    .event = EVENT_STATE_CHANGE,
    .flags = 0,
};
```

3. Use notifier object and register for the event.

```
XPm_RegisterNotifier(&notifier);
```

4. Unregister for the event.

```
XPm_UnregisterNotifier(&notifier);
```

Event Management in Linux

In Linux the event management driver allows an agent driver to register handlers for the platform management events. These events can be power management events such as suspend callback, zero users, device state change, or any error event.

When an agent driver registers for the specific event, the event manager registers those events with the firmware. When any of these registered events occurs, the firmware notifies the ATF through the IPI. The ATF informs the Linux event manager driver through the SGI. During the event manager driver initialization, it informs the ATF about which SGI to use for the communication through the `PM_IOCTL_EEMI_API`.

When the event manager driver gets the SGI interrupt, it reads callback data to know which event has occurred and then calls the respective agent driver handler based on the event. The agent driver can unregister for the event when it does not need the event for which handler was previously registered, to be notified.

Registering and Unregistering the Event Handler

Use the `xlnx_register_event()` API to register handler for the event(s). You can register a single handler for multiple events by using the OR operator on multiple event masks.

```
int xlnx_register_event(const enum pm_api_cb_id cb_type, const u32 node_id,
                       const u32 event, const bool wake, event_cb_func_t cb_fun, void *data)
```

where,

- **cb_type:** Type of callback from `pm_api_cb_id`
 - `PM_NOTIFY_CB` for error events.
 - `PM_INIT_SUSPEND_CB` for suspend callbacks.
- **node_id:** The node ID related to the event.
- **event:** The event mask for the error event.
- **wake:** Flag specifying whether the subsystem should be woken upon event notification.
- **cb_fun:** Function pointer to store the callback function.
- **data:** Pointer for the driver instance.

For example, register and unregister for the `EVENT_ERROR_PMC_ERR1` bit(0) and bit(1) errors:

```
ret = xlnx_register_event(PM_NOTIFY_CB, EVENT_ERROR_PMC_ERR1 , (0x1 | 0x2),
false, pmc_err1_handler, (void *) data);
ret = xlnx_unregister_event(PM_NOTIFY_CB, EVENT_ERROR_PMC_ERR1 , (0x1 |
0x2), pmc_err1_handler);
```

For a complete list of the available error events, refer to the *Versal ACAP Technical Reference Manual* ([AM011](#)).

XilPM Client Implementation Details

The system layer of the platform management is implemented on the Versal ACAP using the IPI. To issue an EEMI API call, a PU writes the API data (API ID and arguments) into the IPI request buffer and then triggers the IPI to the PMC.

After the PMC processes the request, it sends the acknowledgment depending on the particular EEMI API and provided arguments.

Payload Mapping for API Calls to PMC

The following data uniquely identifies each EEMI API call:

- EEMI API identifier (ID)
- EEMI API arguments

See *OS and Libraries Document Collection* ([UG643](#)) for a list of all API identifiers as well as API argument values.

Before initiating an IPI to the PMC, the PU writes the information about the call into the IPI request buffer. Each data written into the IPI buffer is a 32-bit word. Total size of the payload is six 32-bit words—one word is reserved for the EEMI API identifier, while the remaining words are used for the arguments. Writing to the IPI buffer starts from offset zero. The information is mapped as follows:

- Word [0] EEMI API ID
- Word [1:5] EEMI API arguments

The IPI response buffer is used to return the status of the operation as well as up to three values.

- Word [0] success or error code
- Word [1:3] value 1..3

Payload Mapping for API Callbacks from the PMC

The EEMI API includes callback functions, invoked by the PMC, sent to a PU.

- Word [0] EEMI API Callback ID
- Word [1:5] EEMI API arguments

See *OS and Libraries Document Collection* ([UG643](#)) for a list of all API identifiers as well as API argument values.

Issuing EEMI API Calls to the PMC

Before issuing an API call to the PMC, a PU must wait until its previous API call is processed by the PMC. Implement a check for completion of a PMC action by reading the corresponding IPI observation register.

Issue an API call by populating the IPI payload buffer with API data and triggering an IPI interrupt to the PMC. For a blocking API call, the PMC responds by populating the response buffer with the status of the operation and up to 3 values. See Appendix B for a list of all errors that can be sent by the PMC if a PM operation was unsuccessful. The PU must wait until the PMC has finished processing the API call prior to reading the response buffer, to ensure that the data in the response buffer is valid.

Figure 38: Example Flow of Issuing API Call to the PMC

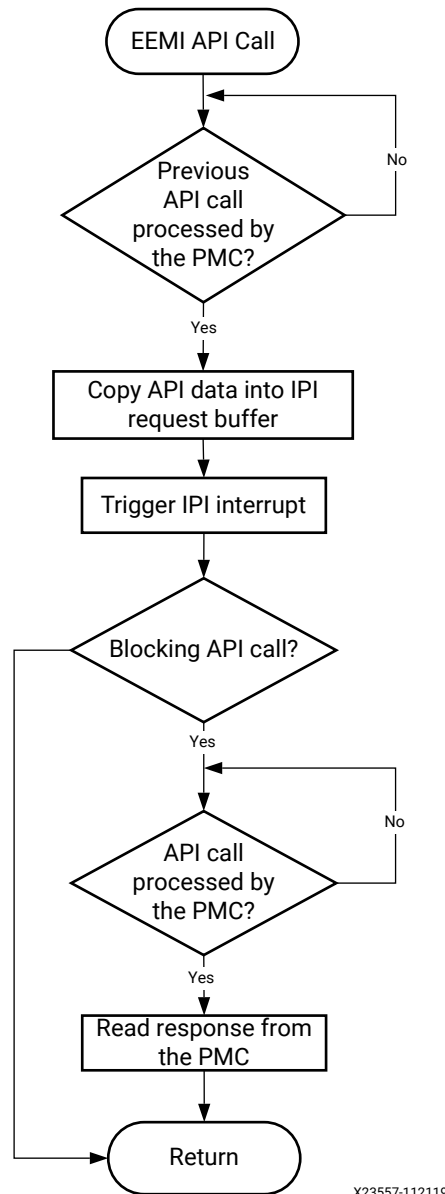

Handling API Callbacks from the PMC

The PMC invokes callback functions to the PU by populating the IPI buffers with the API callback data and triggering an IPI interrupt to the PU. To receive such interrupts, the PU must properly initialize the IPI block and interrupt controller. A single interrupt is dedicated to all callbacks. For this reason, element 0 of the payload buffer contains the API ID, which the PU should use to identify the API callback. The PU should then call the respective API callback function, passing in the arguments obtained from locations 1 to 4 of the IPI request buffer.

The XilPM library contains an implementation of this behavior.

PM Features in Linux

Note: Arm® AArch64 architecture is common between Zynq UltraScale+ MPSoC APU and the Versal™ ACAP APU. The existing architectural reference nomenclature found in the Linux source also applies to Versal devices.

Linux executes at EL1, and the communication between Linux and the ATF software layer is realized using SMC calls. Power management features based on the EEMI API have been ported to the Linux kernel, ensuring that the Linux-centric power management features use the EEMI services provided by the PMC. Additionally, the EEMI API can be accessed directly via `debugfs` for debugging purposes. Note that direct access to the EEMI API through `debugfs` will interfere with the kernel power management operations and may cause unexpected problems. All the Linux power management features presented in this chapter are available in the PetaLinux default configuration.

User Space Platform Management Interface

System Power States

Platform management facilitates the switching of the system or subsystem to the new power state. You can request to change the power state of a subsystem or the entire system.

See [System PM](#) for all the power state of a system and how to enable/disable them.

Power Management for the CPU

You can control CPU power using CPU hot-plugging, CPU idle, and CPU frequencies feature as follows.

CPU Hot-Plugging

This feature can be used to set one or more APU cores on-line and off-line as needed using the CPU hot-plug control interface.

See [CPU Hot-plug](#) for more information.

CPU Idle

Use the CPU idle feature to cut power to individual APU cores when they are idling.

See [CPI Idle](#) for more information.

CPU Frequencies

This feature permits the CPU cores to switch between different operation clock frequencies.

See [CPU Frequency](#) for more information.

Power Management for the Devices

You can control device power with the help of the following features.

Clock Gating

This feature stops device clocks when they are not being used (also called Common Clock Framework).

See [Common clock framework](#) for more information.

Run-time Power Management

This feature powers off devices when they are not being used.

Note: Individual drivers might or might not support run-time power management.

See [Runtime Power Management](#) for more information.

Global General Storage Registers

Four 32-bit storage registers are available for general use. Their values are not preserved after software reboots.

Persistent Global General Storage Registers

Four 32-bit persistent global storage registers are available for general use. Their values are preserved after software reboot. See [Global Storage Registers](#) for more information.

The following registers are reserved.



RECOMMENDED: Xilinx recommends that you do not use reserved registers.

Table 39: Reserved Storage Registers

Register	Description
PMC_GLOBAL_GLOBAL_GEN_STORAGE0, PMC_GLOBAL_GLOBAL_GEN_STORAGE1	Contains the ROM execution time stamp. When PLM is active, it reads these two registers to obtain the execution time of ROM. Registers can be used after loading boot PDI.
PMC_GLOBAL_GLOBAL_GEN_STORAGE2	Contains device security status, updated by ROM. PLM uses this register to determine if KAT needs to be performed.
PMC_GLOBAL_GLOBAL_GEN_STORAGE4	Used by PLM to store ATF handoff parameter address pointer.
PMC_GLOBAL_PERS_GLOB_GEN_STORAGE0	Reserved for XilIPM to save the status of each power domain initialization.
PMC_GLOBAL_PERS_GLOB_GEN_STORAGE1	Not yet used in PLM but intended for data sharing between PLM and debugger.

Debug Interface

The PM platform driver exports a standard `debugfs` interface to access all EEMI services. The interface is only intended for testing and does not contain any checking regarding improper usage, and the number, type, and valid ranges of the arguments.



CAUTION! *Invoking EEMI services directly through this interface can very easily interfere with the kernel power management operations, resulting in unexpected behavior or a system crash.*

See [Debugfs](#) for more information.

PM Linux Drivers

The Versal ACAP power management for Linux is encapsulated in a power management driver, power domain driver, and platform firmware driver. The system-level API functions are exported and can be called by other Linux modules with GPL compatible license.

See [Firmware Driver](#) for more information about platform firmware driver.

Arm Trusted Firmware

The Arm trusted firmware (ATF) executes at EL3. It supports the EEMI API for managing the power state of the slave nodes, by sending PM requests through the IPI-based communication to the PMC. This section is specific to Platform Management support in ATF. For generic information on ATF, see [Trusted Firmware-A Documentation](#).

Event Handling in ATF

The ATF registers for the IPI interrupts during boot. The PLM sends IPI to the ATF when any event occurs along with event data in IPI payload. The ATF then sends an SGI to Linux to notify that some event has occurred. This SGI number is provided by Linux during Event Manager driver initialization using IOCTL EEMI call (`IOCTL_SET_SGI`).

The ATF provides a callback through which Linux can read the IPI data to identify the event that has occurred and sends an IPI acknowledgment to the PLM when Linux reads IPI data.

ATF Application Binary Interface

All APU executable layers below EL3 can communicate indirectly with the PMC through the ATF. The ATF receives all calls made from the lower EL software, consolidates all requests, and sends the requests to the PMC.

Following the Arm® SMC calling convention, the PM communication from the non-secure world to the ATF is organized as SiP Service Calls, using a predefined SMC function identifier and SMC sub-range ownership.

The EEMI API implementation for the APU is compliant only with the SMC64 calling convention. EEMI API calls made from the hypervisor, secure OS, or OS and pass the 32-bit API ID as the SMC Function Identifier, and up to four 32-bit arguments as well. As all PM arguments are 32-bit values, pairs of two are combined into one 64-bit value.

ATF returns up to five 32-bit return values:

- Return status, either success or error and reason
- Additional information from the PM controller

Checking the API Version

Before using the EEMI API to manage the slave nodes, you must check that the EEMI API version implemented in the ATF matches the version implemented in the PLM. EEMI API version is a 32-bit value separated in higher 16-bits of MAJOR and lower 16-bits of MINOR part. Both fields must be the same between the ATF and the PLM.

How to Check the EEMI API Version

The EEMI version implemented in the ATF is defined in the local `EEMI_API_VERSION` flag. The rich OS can invoke the `PM_GET_API_VERSION` function to retrieve the EEMI API version from the PMC. If the versions are different, this function reports an error.

Note: This EEMI API function is version independent; every EEMI version implements it.

Checking the Chip ID

Linux or another rich OS can invoke the `PM_GET_CHIPID` function using SMC to retrieve the chip ID information from the PMC. The return values are as follows:

- TAP idcode register
- TAP version register

For more details, see the *Versal ACAP Technical Reference Manual* ([AM011](#)).

Power State Coordination Interface

The Power State Coordination Interface (PSCI) is a standard interface for controlling the system power state of Arm processors, such as suspend, shutdown, and reboot. For the PSCI specifications, see <http://infocenter.arm.com/help/index.jsp?topic=/com.arm.doc.den0022c/index.html>.

ATF handles the PSCI requests from Linux. ATF only supports PSCI v0.2 (with no backward compatible support for v0.1).

The Linux kernel comes with standard support for PSCI. For information about the binding between the kernel and the ATF/PSCI, see <https://www.kernel.org/doc/Documentation/devicetree/bindings/arm/psci.txt>.

The following table lists the PSCI v0.2 functions that ATF supports.

Table 40: PSCI v0.2 Functions Supported by ATF

Function	Description	Supported?
PSCI Version	Return the implemented PSCI version.	Yes
CPU Suspend	Suspend execution on a core or higher level topology node. This call is intended for use in idle subsystems where the core is expected to return to execution through a wake-up event.	Yes
CPU On	Power up a core. This call is used to power up cores that either: <ul style="list-style-type: none"> Have not yet been booted into the calling supervisory software. Have been previously powered down with a CPU_OFF call. 	Yes
CPU Off	Power down the calling core. This call is intended for use in a hotplug. A core that is powered down by CPU_OFF can only be powered up again in response to a CPU_ON.	Yes
Affinity Info	Enable the caller to request status of an affinity instance.	Yes
Migrate (Optional)	This is used to ask a uniprocessor trusted OS to migrate its context to a specific core.	Yes
Migrate Info Type (Optional)	This function allows a caller to identify the level of multicore support present in the trusted OS.	Yes
Migrate Info Up CPU (Optional)	For a uniprocessor Trusted OS, this function returns the current resident core.	Yes
System Off	Shut down the system.	Yes
System Reset	Reset the system.	Yes

Table 40: PSCI v0.2 Functions Supported by ATF (cont'd)

Function	Description	Supported?
PSCI Features	Introduced in PSCI v1.0. Query API that allows discovering whether a specific PSCI function is implemented and its features.	Yes
CPU Freeze (Optional)	Introduced in PSCI v1.0. Places the core into an IMPLEMENTATION DEFINED low-power state. Unlike CPU_OFF it is still valid for interrupts to be targeted to the core. However, the core must remain in the low power state until it a CPU_ON command is issued for it.	No
CPU Default Suspend (Optional)	Introduced in PSCI v1.0. Will place a core into an IMPLEMENTATION DEFINED low-power state. Unlike CPU_SUSPEND, the caller does not need to specify a power state parameter.	No
Node HW State (Optional)	Introduced in PSCI v1.0. This function is intended to return the true hardware state of a node in the power domain topology of the system.	Yes
System Suspend (Optional)	Introduced in PSCI v1.0. Used to implement suspend to RAM. The semantics are equivalent to a CPU_SUSPEND to the deepest low-power state.	Yes
PSCI Set Suspend Mode (Optional)	Introduced in PSCI v1.0. This function allows setting the mode used by CPU_SUSPEND to coordinate power states.	No
PSCI Stat Residency (Optional)	Introduced in PSCI v1.0. Returns the amount of time the platform has spent in the given power state because cold boot.	Yes
PSCI Stat Count (Optional)	Introduced in PSCI v1.0. Return the number of times the platform has used the given power state because of cold boot.	Yes

PS Management Controller Firmware

The PS management controller (PSM) is a separate, MicroBlaze processor with a triple modular redundancy MicroBlaze implementation in the PS domain. The PSM firmware, that runs on the PSM, is in charge of managing power PS power islands and domains. The PMC leverages functions implemented in the PSM firmware to power up or down the PS power islands and domains. These functions are exposed only to the PLM.

When an EEMI request results in changing the state of a power island or a power domain, the PLM triggers an interrupt handler in the PSM to handle that operation. There is also an IPI channel assigned to the PSM to communicate with the PLM on completion of the operation.

Relationship with PLM

The EEMI service handlers are implemented in the PLM, as one of the modules called a PM Controller (there are other modules running in the PLM to handle other types of services). For more details, see the [Chapter 7: Boot and Configuration](#).

Embedded Energy Management Interface (EEMI)

EEMI API events are software-generated events. The events are triggered using IPI interrupts when a PM master initiates an EEMI API call to the PMC. The PM Controller handles the EEMI request. An EEMI request often triggers a change in the power state, or change in configuration of a resource.

General Flow of an EEMI API Call

The following figure shows the typical API sequence call, starting with the call initiated by a PM master (such as another processing unit).

Figure 39: EEMI API Call Sequence

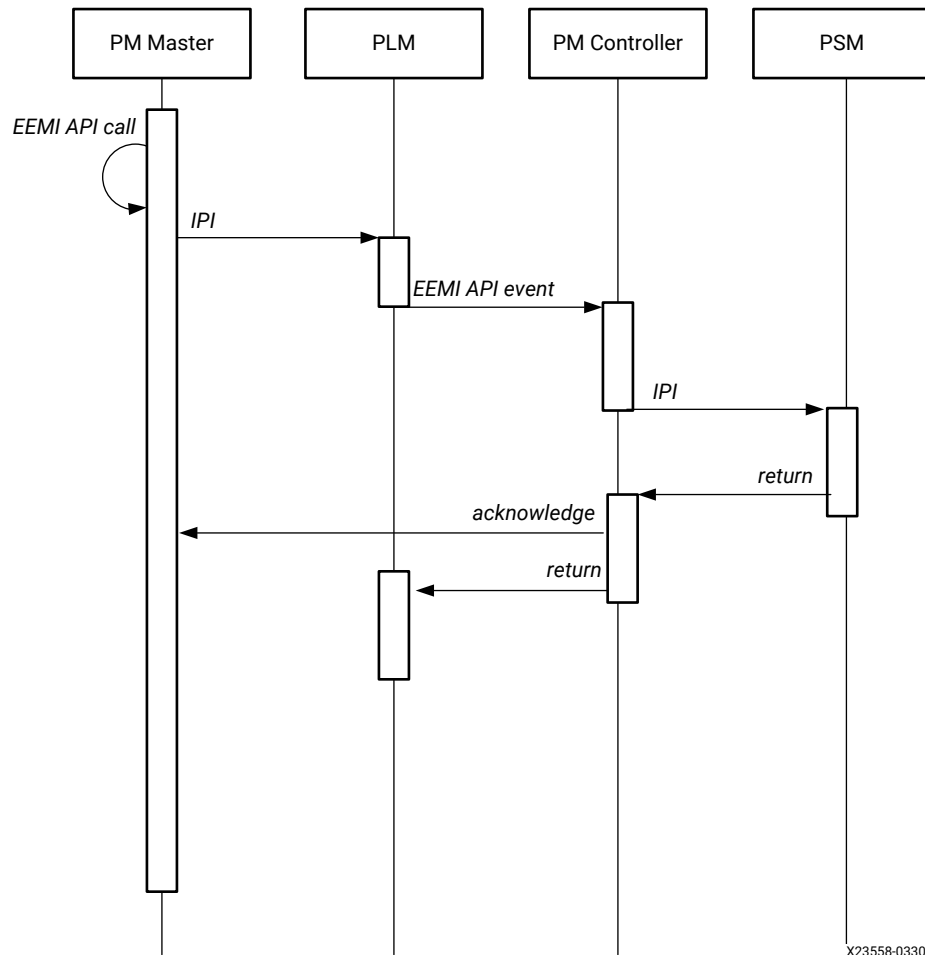

X23558-033020

The figure shows four actors; the first actor represents the PM master, which is either the RPU, APU, or a MicroBlaze processor core. The remaining three actors are the PLM, PMC, and PSM.

First, the PLM receives the IPI interrupt. After the interrupt has been identified as a power management-related interrupt, the IPI arguments are passed to the XilPM server. The XilPM server then processes the API call. If necessary, the XilPM server can call the PSM firmware to perform some power management operations, such as powering on or powering off a power island, or a power domain.

PSM Health Check in PLM

PLM periodically checks whether PSM is alive and healthy by sending IPI notifications to PSMFW. Both PLM and PSM firmware maintain counters and periodically make sure that they are in sync. If PSM is not alive and healthy, PLM throws the PSM keep alive error. The PLM can also notify you about the PSM keep alive error if you have registered for the PSM keep alive error.

Target Development Platforms

This chapter describes the various development platforms available for Versal ACAP, such as boards and kits.

The following platforms are available:

- **AI Core Series:** High-compute series with medium density programmable logic and connectivity capability coupled with AI and DSP acceleration engines.
- **Prime Series:** Mid-range series with medium density PL, signal processing, and connectivity capability.
- **Premium Series:** High-end, high-bandwidth series, rich in networking interfaces, security engines, and providing high compute density.

Boards and Kits

Xilinx provides the Versal ACAP device evaluation kit for developers.

Currently, there are two evaluation kits available for Versal ACAP devices:

- **VCK190:** AI Core series evaluation kit. For more details on the VCK190 board, refer to the *VCK190 Evaluation Board User Guide* ([UG1366](#)).
- **VMK180:** Prime series evaluation kit. For more details on the VMK180 board, refer to *VMK180 Evaluation Board User Guide* (UG1411).

Libraries

See *OS and Libraries Document Collection* ([UG643](#)) for information on API reference for the following Versal ACAP libraries.

- LwIP
- XiIFFS
- XiIFPGA
- XiIMailbox
- XiIPM
- XiISEM

Additional Resources and Legal Notices

Xilinx Resources

For support resources such as Answers, Documentation, Downloads, and Forums, see [Xilinx Support](#).

Documentation Navigator and Design Hubs

Xilinx® Documentation Navigator (DocNav) provides access to Xilinx documents, videos, and support resources, which you can filter and search to find information. To open DocNav:

- From the Vivado® IDE, select **Help** → **Documentation and Tutorials**.
- On Windows, select **Start** → **All Programs** → **Xilinx Design Tools** → **DocNav**.
- At the Linux command prompt, enter `docnav`.

Xilinx Design Hubs provide links to documentation organized by design tasks and other topics, which you can use to learn key concepts and address frequently asked questions. To access the Design Hubs:

- In DocNav, click the **Design Hubs View** tab.
- On the Xilinx website, see the [Design Hubs](#) page.

Note: For more information on DocNav, see the [Documentation Navigator](#) page on the Xilinx website.

References

These documents provide supplemental material useful with this guide:

Xilinx References

1. [PetaLinux Tools](#)
2. [Xilinx Vivado Design Suite – HLx Editions](#)
3. [Xilinx Third-Party Tools](#)
4. [Embedded Software & Ecosystem](#)

Devices Documentation

1. *Versal ACAP AI Engine Architecture Manual* ([AM009](#))
2. *Versal ACAP Technical Reference Manual* ([AM011](#))
3. *Versal Architecture and Product Data Sheet: Overview* ([DS950](#))
4. *Versal ACAP Programmable Network on Chip and Integrated Memory Controller LogiCORE IP Product Guide* ([PG313](#))
5. *OS and Libraries Document Collection* ([UG643](#))
6. *Versal ACAP AI Engine Programming Environment User Guide* ([UG1076](#))
7. *Embedded Energy Management Interface EEMI API Reference Guide* ([UG1200](#))
8. *Versal ACAP Design Guide* ([UG1273](#))
9. *Bootgen User Guide* ([UG1283](#))
10. *Xilinx Embedded Design Tutorials: Versal Adaptive Compute Acceleration Platform* ([UG1305](#))
11. *VCK190 Evaluation Board User Guide* ([UG1366](#))
12. *Versal ACAP QEMU User Guide* ([UG1372](#))
13. *VMK180 Evaluation Board User Guide* ([UG1411](#))

Tools and PetaLinux Documentation

1. *Zynq UltraScale+ MPSoC: Software Developers Guide* ([UG1137](#))
2. *PetaLinux Tools Documentation: Reference Guide* ([UG1144](#))
3. *Bootgen User Guide* ([UG1283](#))
4. *Vitis Unified Software Platform Documentation* ([UG1416](#))

Miscellaneous Links

1. <https://github.com/Xilinx/linux-xlnx/>
2. https://github.com/torvalds/linux/blob/master/drivers/soc/xilinx/zynqmp_pm_domains.c
3. <https://xilinx-wiki.atlassian.net/wiki/spaces/A/pages/18842279/Build+Device+Tree+Blob>
4. <https://xilinx-wiki.atlassian.net/wiki/spaces/A/pages/18841996/Linux#Linux-XilinxLinux>

5. <https://xilinx-wiki.atlassian.net/wiki/spaces/A/pages/18842250/PetaLinux>
6. <https://xilinx-wiki.atlassian.net/wiki/spaces/A/pages/18842316/Linux+Prebuilt+Images>
7. <https://xilinx-wiki.atlassian.net/wiki/spaces/A/pages/18841718/OpenAMP>
8. <https://xilinx-wiki.atlassian.net/wiki/spaces/A/pages/18842530/XEN+Hypervisor>
9. <https://xilinx-wiki.atlassian.net/wiki/spaces/A/pages/18841883/Yocto>

Third-Party References

1. <https://developer.arm.com/docs/ddi0487/latest/arm-architecture-reference-manual-armv8-for-armv8-a-architecture-profile>
2. <https://www.yoctoproject.org/software-overview/downloads/>
3. <https://git.yoctoproject.org/cgiit/cgiit.cgi/meta-xilinx/>
4. <https://www.kernel.org/doc/Documentation/devicetree/bindings/arm/psci.txt>
5. <http://infocenter.arm.com/help/index.jsp?topic=/com.arm.doc.den0022c/index.html>
6. <https://www.kernel.org/doc/Documentation/cpuidle/core.txt>
7. <https://www.kernel.org/doc/Documentation/cpuidle/driver.txt>
8. <https://www.kernel.org/doc/Documentation/cpuidle/governor.txt>
9. <https://www.kernel.org/doc/Documentation/cpuidle/sysfs.txt>
10. <https://www.kernel.org/doc/Documentation/cpuidle/sysfs.txt>
11. <https://www.kernel.org/doc/Documentation/devicetree/bindings/opp/opp.txt>
12. <http://lxr.free-electrons.com/source/Documentation/devicetree/bindings/arm/idlestates.txt>
13. <https://www.kernel.org/doc/Documentation/cpu-hotplug.txt>
14. https://wiki.archlinux.org/index.php/Power_management/Suspend_and_hibernate

Please Read: Important Legal Notices

The information disclosed to you hereunder (the "Materials") is provided solely for the selection and use of Xilinx products. To the maximum extent permitted by applicable law: (1) Materials are made available "AS IS" and with all faults, Xilinx hereby DISCLAIMS ALL WARRANTIES AND CONDITIONS, EXPRESS, IMPLIED, OR STATUTORY, INCLUDING BUT NOT LIMITED TO WARRANTIES OF MERCHANTABILITY, NON-INFRINGEMENT, OR FITNESS FOR ANY PARTICULAR PURPOSE; and (2) Xilinx shall not be liable (whether in contract or tort, including negligence, or under any other theory of liability) for any loss or damage of any kind or nature related to, arising under, or in connection with, the Materials (including your use of the Materials), including for any direct, indirect, special, incidental, or consequential loss or damage

(including loss of data, profits, goodwill, or any type of loss or damage suffered as a result of any action brought by a third party) even if such damage or loss was reasonably foreseeable or Xilinx had been advised of the possibility of the same. Xilinx assumes no obligation to correct any errors contained in the Materials or to notify you of updates to the Materials or to product specifications. You may not reproduce, modify, distribute, or publicly display the Materials without prior written consent. Certain products are subject to the terms and conditions of Xilinx's limited warranty, please refer to Xilinx's Terms of Sale which can be viewed at <https://www.xilinx.com/legal.htm#tos>; IP cores may be subject to warranty and support terms contained in a license issued to you by Xilinx. Xilinx products are not designed or intended to be fail-safe or for use in any application requiring fail-safe performance; you assume sole risk and liability for use of Xilinx products in such critical applications, please refer to Xilinx's Terms of Sale which can be viewed at <https://www.xilinx.com/legal.htm#tos>.

This document contains preliminary information and is subject to change without notice. Information provided herein relates to products and/or services not yet available for sale, and provided solely for information purposes and are not intended, or to be construed, as an offer for sale or an attempted commercialization of the products and/or services referred to herein.

AUTOMOTIVE APPLICATIONS DISCLAIMER

AUTOMOTIVE PRODUCTS (IDENTIFIED AS "XA" IN THE PART NUMBER) ARE NOT WARRANTED FOR USE IN THE DEPLOYMENT OF AIRBAGS OR FOR USE IN APPLICATIONS THAT AFFECT CONTROL OF A VEHICLE ("SAFETY APPLICATION") UNLESS THERE IS A SAFETY CONCEPT OR REDUNDANCY FEATURE CONSISTENT WITH THE ISO 26262 AUTOMOTIVE SAFETY STANDARD ("SAFETY DESIGN"). CUSTOMER SHALL, PRIOR TO USING OR DISTRIBUTING ANY SYSTEMS THAT INCORPORATE PRODUCTS, THOROUGHLY TEST SUCH SYSTEMS FOR SAFETY PURPOSES. USE OF PRODUCTS IN A SAFETY APPLICATION WITHOUT A SAFETY DESIGN IS FULLY AT THE RISK OF CUSTOMER, SUBJECT ONLY TO APPLICABLE LAWS AND REGULATIONS GOVERNING LIMITATIONS ON PRODUCT LIABILITY.

Copyright

© Copyright 2020-2021 Xilinx, Inc. Xilinx, the Xilinx logo, Alveo, Artix, Kintex, Spartan, Versal, Virtex, Vivado, Zynq, and other designated brands included herein are trademarks of Xilinx in the United States and other countries. AMBA, AMBA Designer, Arm, ARM1176JZ-S, CoreSight, Cortex, PrimeCell, Mali, and MPCore are trademarks of Arm Limited in the EU and other countries. PCI, PCIe, and PCI Express are trademarks of PCI-SIG and used under license. All other trademarks are the property of their respective owners.