

## Summary

The Xilinx<sup>®</sup> Varium<sup>™</sup> C1100, shown in the following figure, is a single slot, full height, half length form factor passively-cooled card operating up to a 75W maximum power limit. It supports PCI Express<sup>®</sup> (PCIe<sup>®</sup>) Gen3 x16 or dual Gen4 x8, contains 8 GB of high-bandwidth memory, and Ethernet networking capability with dual QSFP28 connectors capable of 8 x 25 Gb/s. The Varium C1100 is a compute adaptor designed to accelerate memory-bound, compute intensive applications in blockchain, financial computing, machine learning, computational storage, and data search and analytics.

*Figure 1: Varium C1100 Compute Adaptor*



# Product Details

Table 1: Varium C1100 Compute Adaptor Product Details

Specification	C1100
Product SKU	V-C1100-P00G-PQG-020
Total electrical card load <sup>1</sup>	75W
Thermal design power (TDP)	70W
Thermal cooling solution	Passive
Weight	516g
Form factor	Full height, half length
Network interface	2 x QSFP28
PCIe interface <sup>2,3</sup>	Gen3 x16, 2 x Gen4 x8, 1 x Gen4 x8, CCIX
HBM total capacity	8 GB
HBM bandwidth	460 GB/s
Look-up tables (LUTs)	872K
Registers	1,743K
DSP slices	5,952
Maximum distributed RAM	24.6 Mb
36 Kb block RAM	47.3 Mb
288 Kb UltraRAM	640 (180.0 Mb)
GTY transceivers	24
Qualified for deployment	Yes

**Notes:**

1. The Varium C1100 card supports multiple power solutions (see [AUX Power Connector](#)), and the electrical power capabilities can exceed the thermal capabilities. The card can be fully powered from the PCI Express slot. Developers must be aware there is a limitation on the VCCINT current (30A) when using PCIe slot power only. It is recommended to use both the PCIe slot power and the PCIe AUX power connection on the rear of the card to utilize the card's full capabilities. The HBM performance is unaffected by the power solution.
2. The PCIe interface can be configured to support a variety of link widths and speeds. The maximum is Gen3 (8 GT/s) x16, Gen4 (16 GT/s) x8 or CCIX operating at 16 GT/s x8. The PCIe interface can also be configured into dual x8 interfaces and connected to hosts that support PCIe bifurcation.
3. This block operates in compatibility mode for 16.0 GT/s (Gen4) operation. Refer to *UltraScale+ Devices Integrated Block for PCI Express LogiCORE IP Product Guide (PG213)* for details on compatibility mode.

# Card Specifications

## Block Diagram

The following figure shows the components within a Variium C1100 compute adaptor.

Figure 2: C1100 Block Diagram

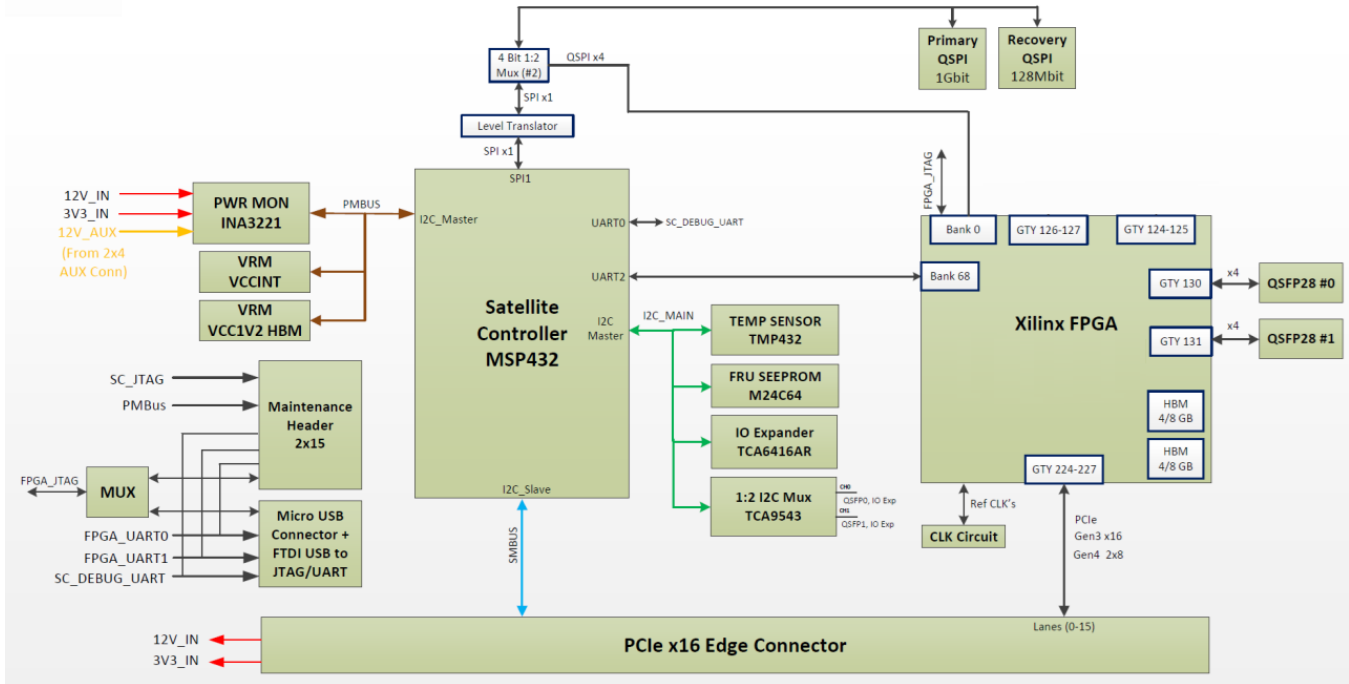

## PCIe Connector/Data Rates

The Variium C1100 compute adaptor uses an UltraScale+™ FPGA containing a PCIE4C block. The PCIE4C block is compliant to the PCI Express Base Specification v3.1 supporting up to 8.0 GT/s (Gen3 x16) and compatible with PCI Express Base Specification v4.0 supporting up to 16.0 GT/s (Gen4 x8). The PCIE4C block is also compliant with CCIX Base Specification Revision 1.0 v0.9, supporting speeds up to 16.0 GT/s. The PCI Express interface can also be configured into dual x8 interfaces and connected to hosts that support PCI Express bifurcation.

Table 2: PCI Express Data Transfer Rate Performance

PCI Express Generation	Performance
Gen 1	2.5 GigaTransfers per second (GT/s)
Gen 2	5.0 GT/s
Gen 3	8.0 GT/s
Gen 4 <sup>1</sup>	16.0 GT/s

**Notes:**

- For a list of limitations when operating at the Gen4 rate, see *UltraScale+ Devices Integrated Block for PCI Express LogiCORE IP Product Guide (PG213)*.

## Network Interfaces

The Varium C1100 card comes with a dual 4-lane QSFP28 that can accept modules up to 3.5W. The QSFP28 can connect interfaces up to 100G using optical modules or cables. A 161.1328125 MHz clock is provided to the QSFP28 interface such that different Ethernet IP cores can be enabled. The Varium C1100 card is shipped with eight unique MAC IDs. These IDs are located on a sticker on the back of the unit and can be retrieved through the Card Management Solution IP. See the *Card Management Solution Subsystem Product Guide (PG348)* for more information.

**Table 3: Network Parameter Description**

Parameter	Description
Network interface type	QSFP28 x2
Targeted use model	100 Gb Ethernet
Operating clock frequency	161.1328125 MHz
Clock precision	IEEE1588
Electrical design power	5W
Thermal design power	3.5W
Thermal restrictions	The QSFP case temperature must be less than 85°C for class 3 optical modules (< 2.5W), and less than 70°C for class 4 optical modules (< 3.5W)

The two QSFP28 port locations on the card, along with link and activity status LEDs are shown in the following figure. QSFP28 port 0 is located closer to the edge connector.

**Figure 3: QSFP28 Ports**

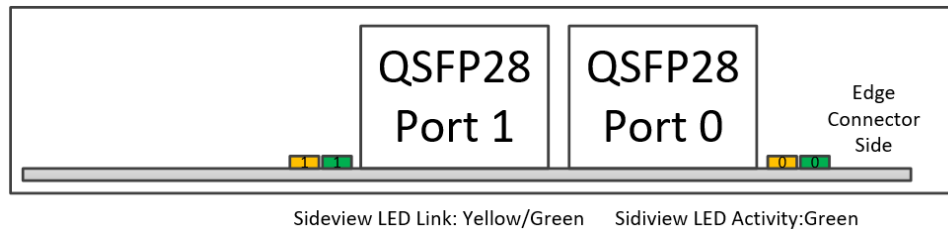

There are two sets of LEDs for each QSFP28 port that are visible from the I/O bracket area. The LED definition is dependent on the port usage and is given in the following table.

**Table 4: Network Link and Activity LED Definition**

Usage	Link LED	Activity LED
100G	Green when physical link is present and operating at the highest supported link rate. Yellow when operating at lower rates. Off in the absence of physical link.	Illuminated or blinking yellow with link activity. Off when there is no activity.
4x25G	Green when all physical links are present and operating at the highest supported link rate. Yellow when any link is operating at a lower rate or is not linked. Off in the absence of physical link on all links.	Illuminated or blinking yellow with link activity on any port. Off when there is no activity on any port.

## Satellite Controller

A TI MSP432 satellite controller resides on the C1100 card to control and monitor voltages, currents and temperatures. The host server board management controller (BMC) can interact with the satellite controller to monitor and control C1100 cards through out-of-band communication. Xilinx supports the PLDM protocol over MCTP over SMBUS, complying with DMTF standards. Refer to the *Alveo Card Out-of-Band Management Specification for Server BMC (XD038)* for more information. When used with the Xilinx provided platform, you can easily monitor for any abnormal operating conditions and react accordingly. If you are not using the platform, Xilinx provides a Card Management Solution IP allowing you to quickly develop and interact with the satellite controller from the FPGA. See the *Card Management Solution Subsystem Product Guide (PG348)* for more information.

## Maintenance Port

The maintenance port allows access to a number of different features and signals including JTAG, UARTs, PMBus, and resets. Connecting the Alveo programming cable to the maintenance port allows access to these features. See the *Alveo Programming Cable User Guide (UG1377)* for more information.

## FPGA Resource Information

The Xilinx Variium C1100 compute adaptor is a custom-built UltraScale+ FPGA that runs optimally (and exclusively) on Variium architecture. The Variium C1100 card features the XCU55N-L2SVH2892E (XCU55N-FSVH2892-2L-E Vivado flow part number), which uses Xilinx stacked silicon interconnect (SSI) technology to deliver breakthrough FPGA capacity, bandwidth, and power efficiency. This technology allows for increased density by combining multiple super logic regions (SLRs).

The following figure shows the two SLR regions of the XCU55N along with the connections for PCIe and QSFP. The HBM is co-located on the XCU55N device and connects directly to SLR0.

Figure 4: Floorplan of the XCU55N Device with Dual QSFP Connection

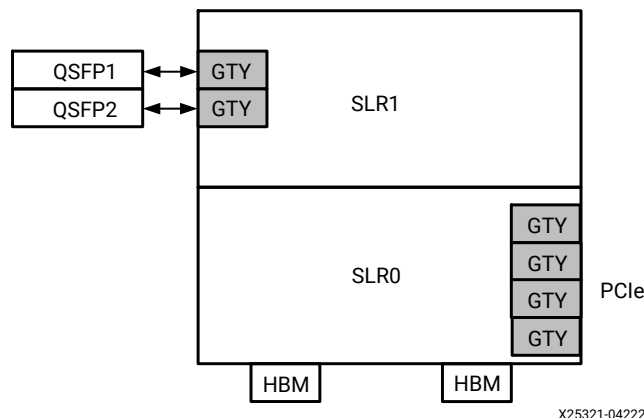

## Qualified Servers

A list of servers on which Alveo cards are fully qualified can be found here: <https://www.xilinx.com/products/boards-and-kits/alveo/qualified-servers.html>.

## Operating System Compatibility

For the most up-to-date operating system support, refer to the *Vitis Unified Software Platform Documentation: Application Acceleration Development* ([UG1393](#)).

## AUX Power Connector

The Varium C1100 compute adaptor includes an 8-pin AUX power connector that provides additional power configurations. All configurations use, at minimum, the 75W PCIe slot power. Connecting a 6-pin or 8-pin AUX power cable provides additional power. The maximum power available for the various AUX power cable configurations is given in the following table.

**Note:** A PCI Express auxiliary power connector is not compatible with an ATX12V/EPS12V power cable source.

*Table 5: Power Availability*

AUX Power Configuration	Maximum Power Available
No AUX power cable connected	75W
2x3 AUX power cable connected	150W
2x4 AUX power cable connected	225W <sup>1</sup>

**Notes:**

- While this configuration supplies a maximum of 225W, the Varium C1100 consumes at most 150W.

## Mechanical

The C1100 card is compliant with the PCIe CEM rev.3.0 Specification as single slot, full height, half length cards.

*Table 6: Card Dimensions*

Parameter	Dimension
Height	4.375 inch (111.15 mm)
PCB thickness ( $\pm 0.13$ mm (0.005 inch))	0.62 inch (1.57 mm)
Primary side width	0.570 inch (14.47 mm)
Secondary side width	0.105 inch (2.67 mm)
Length	6.60 inch (167.65 mm)

## Thermal

### Operating and Storage Temperature Conditions

*Table 7: Operating and Storage Temperatures and Humidity Conditions*

Specification	Condition
Operating temperature	0°C to 55°C
Storage temperature	-40°C to 75°C

Table 7: Operating and Storage Temperatures and Humidity Conditions (cont'd)

Specification	Condition
Operating humidity, non-condensing	8% to 90%, and a dew point of -12°C
Storage humidity, non-condensing	5% to 95%

## Airflow Direction Support

Forced airflow is required at all times when the card is powered on. The card supports front-to-back airflow as illustrated in the following figure. It also supports back-to-front (reverse) airflow.

Figure 5: Recommended Airflow Direction for C1100 Card

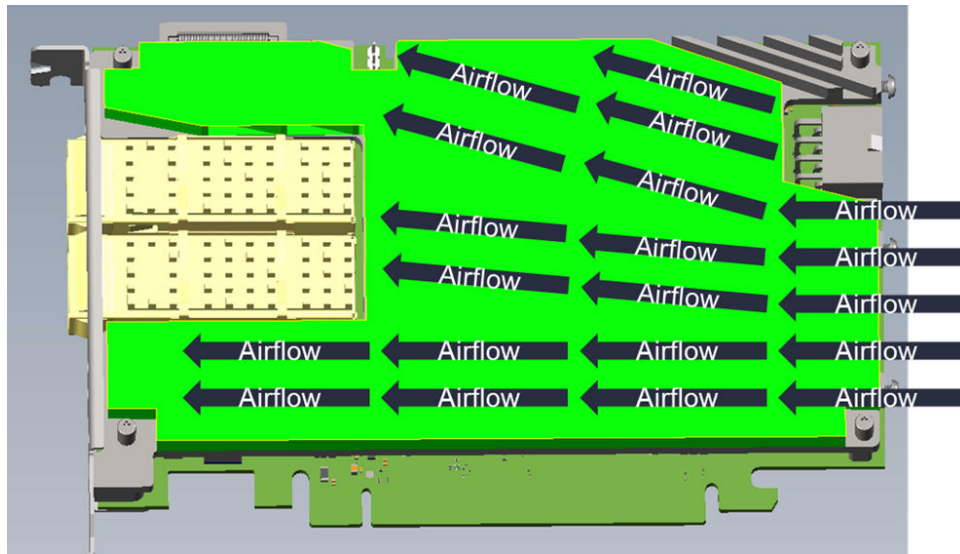

X24095-060820

**Note:** Other environmental conditions are possible, including bidirectional flow. However, this is specific to server configurations, and testing is performed by individual OEMs. Contact your server provider for more information and options.

## Operating Conditions

### Inlet Temperature versus Airflow Requirement in Server

The following tables provide the required airflow rate and airflow speed to the Variium C1100 card under various operating conditions.

**Note:** The data in the following tables is preliminary and subject to change. Thermal tests performed on cards without QSFP modules results in more FPGA power being consumed compared with tests performed with QSFP modules.



**Table 8: Inlet Temperature versus Airflow Requirement of PCIe Card Slot (98.4 mm x 20.33 mm) for Normal Flow at Sea Level for 85°C Optical with 115W Total Card Power**

Inlet Temperature to the Card (°C)	With QSFP			Without QSFP		
	Cubic Feet per Minute (CFM)	Linear Feet per Minute (LFM)	Static Pressure (inwg)	Cubic Feet per Minute (CFM)	Linear Feet per Minute (LFM)	Static Pressure (inwg)
25	6.8	315	0.15	6.6	307	0.16
30	7.9	367	0.20	7.7	358	0.20
35	9.3	434	0.26	9.1	424	0.27
40	11.3	525	0.37	11.0	512	0.37
45	14.0	652	0.54	13.6	632	0.53
50	18.1	840	0.86	17.3	801	0.80
55	24.6	1141	1.53	22.7	1055	1.32

**Table 9: Inlet Temperature versus Airflow Requirement of PCIe Card Slot (98.4 mm x 20.33 mm) for Normal Flow at 1200m above Sea Level for 85°C Optical with 115W Total Card Power**

Inlet Temperature to the Card (°C)	With QSFP			Without QSFP		
	Cubic Feet per Minute (CFM)	Linear Feet per Minute (LFM)	Static Pressure (inwg)	Cubic Feet per Minute (CFM)	Linear Feet per Minute (LFM)	Static Pressure (inwg)
25	7.3	336	0.17	7.1	328	0.18
30	8.5	394	0.22	8.3	384	0.23
35	10.0	466	0.30	9.8	456	0.30
40	12.1	564	0.42	11.9	551	0.41
45	15.1	702	0.62	14.6	680	0.60
50	19.5	906	0.99	18.6	864	0.92
55	26.5	1232	1.77	24.5	1139	1.52

**Table 10: Inlet Temperature versus Airflow Requirement of PCIe Card Slot (98.4 mm x 20.33 mm) for Normal Flow at Sea Level for 85°C Optical with 135W Total Card Power**

Inlet Temperature to the Card (°C)	With QSFP			Without QSFP		
	Cubic Feet per Minute (CFM)	Linear Feet per Minute (LFM)	Static Pressure (inwg)	Cubic Feet per Minute (CFM)	Linear Feet per Minute (LFM)	Static Pressure (inwg)
25	8.7	401	0.23	8.7	402	0.24
30	10.1	466	0.30	10.1	470	0.32
35	12.0	552	0.40	12.0	557	0.42
40	14.5	667	0.57	14.5	672	0.59
45	17.9	828	0.84	17.9	829	0.85
50	23.0	1068	1.35	22.7	1052	1.31
55	31.2	1450	2.41	29.8	1385	2.18



**Table 11: Inlet Temperature versus Airflow Requirement of PCIe Card Slot (98.4 mm x 20.33 mm) for Normal Flow at 1200m above Sea Level for 85°C Optical with 135W Total Card Power**

Inlet Temperature to the Card (°C)	With QSFP			Without QSFP		
	Cubic Feet per Minute (CFM)	Linear Feet per Minute (LFM)	Static Pressure (inwg)	Cubic Feet per Minute (CFM)	Linear Feet per Minute (LFM)	Static Pressure (inwg)
25	9.3	428	0.27	9.3	431	0.27
30	10.9	500	0.34	10.9	504	0.36
35	12.9	592	0.46	12.9	598	0.48
40	15.6	717	0.65	15.6	723	0.67
45	19.2	892	0.97	19.2	893	0.97
50	24.8	1151	1.56	24.4	1134	1.51
55	33.7	1565	2.79	32.2	1494	2.52

**Table 12: Inlet Temperature versus Airflow Requirement of PCIe Card Slot (98.4 mm x 20.33 mm) for Normal Flow at Sea Level for 85°C Optical with 150W Total Card Power**

Inlet Temperature to the Card (°C)	With QSFP			Without QSFP		
	Cubic Feet per Minute (CFM)	Linear Feet per Minute (LFM)	Static Pressure (inwg)	Cubic Feet per Minute (CFM)	Linear Feet per Minute (LFM)	Static Pressure (inwg)
25	10.4	483	0.30	10.4	481	0.33
30	12.1	562	0.40	12.1	562	0.43
35	14.3	664	0.53	14.3	666	0.58
40	17.3	803	0.76	17.3	804	0.81
45	21.3	989	1.13	21.3	991	1.18
50	27.1	1259	1.82	27.1	1258	1.83
55	36.6	1698	3.25	35.6	1655	3.06

**Table 13: Inlet Temperature versus Airflow Requirement of PCIe Card Slot (98.4 mm x 20.33 mm) for Normal Flow at 1200m above Sea Level for 85°C Optical with 150W Total Card Power**

Inlet Temperature to the Card (°C)	With QSFP			Without QSFP		
	Cubic Feet per Minute (CFM)	Linear Feet per Minute (LFM)	Static Pressure (inwg)	Cubic Feet per Minute (CFM)	Linear Feet per Minute (LFM)	Static Pressure (inwg)
25	11.1	515	0.36	11.1	515	0.37
30	13.0	604	0.45	13.0	603	0.49
35	15.4	715	0.61	15.4	715	0.66
40	18.6	864	0.86	18.6	864	0.92
45	23.0	1068	1.29	23.0	1067	1.35
50	29.2	1356	2.09	29.2	1356	2.10
55	39.5	1832	3.77	38.5	1787	3.53

**Table 14: Inlet Temperature versus Airflow Requirement of PCIe Card Slot (104.57 mm x 13.18 mm) for Reverse Flow at Sea Level for 85°C Optical with 115W Total Card Power**

Inlet Temperature to the Card (°C)	With QSFP			Without QSFP		
	Cubic Feet per Minute (CFM)	Linear Feet per Minute (LFM)	Static Pressure (inwg)	Cubic Feet per Minute (CFM)	Linear Feet per Minute (LFM)	Static Pressure (inwg)
25	8.6	582	0.71	10.1	681	0.49
30	10.0	673	0.92	11.7	788	0.64
35	11.7	789	1.24	13.7	924	0.86
40	13.9	940	1.73	16.3	1101	1.20
45	17.0	1144	2.52	19.9	1341	1.75
50	21.2	1429	3.86	24.9	1675	2.69
55	27.4	1848	6.35	32.2	2167	4.43

**Table 15: Inlet Temperature versus Airflow Requirement of PCIe Card Slot (104.57 mm x 13.18 mm) for Reverse Flow at 1200m above Sea Level for 85°C Optical with 115W Total Card Power**

Inlet Temperature to the Card (°C)	With QSFP			Without QSFP		
	Cubic Feet per Minute (CFM)	Linear Feet per Minute (LFM)	Static Pressure (inwg)	Cubic Feet per Minute (CFM)	Linear Feet per Minute (LFM)	Static Pressure (inwg)
25	9.2	623	0.80	10.8	730	0.55
30	10.7	722	1.05	12.5	845	0.73
35	12.6	847	1.42	14.7	992	0.99
40	15.0	1011	1.99	17.6	1184	1.38
45	18.3	1232	2.90	21.4	1443	2.02
50	22.9	1540	4.46	26.8	1806	3.11
55	29.6	1994	7.36	34.7	2339	5.14

**Table 16: Inlet Temperature versus Airflow Requirement of PCIe Card Slot (104.57 mm x 13.18 mm) for Reverse Flow at Sea Level for 85°C Optical with 135W Total Card Power**

Inlet Temperature to the Card (°C)	With QSFP			Without QSFP		
	Cubic Feet per Minute (CFM)	Linear Feet per Minute (LFM)	Static Pressure (inwg)	Cubic Feet per Minute (CFM)	Linear Feet per Minute (LFM)	Static Pressure (inwg)
25	11.3	760	1.16	12.9	872	0.77
30	13.0	879	1.52	15.0	1009	1.02
35	15.3	1030	2.06	17.5	1183	1.38
40	18.2	1228	2.88	20.9	1410	1.93
45	22.2	1494	4.21	25.5	1716	2.82
50	27.7	1867	6.48	31.8	2145	4.34
55	35.8	2414	10.69	41.2	2775	7.18

**Table 17: Inlet Temperature versus Airflow Requirement of PCIe Card Slot (104.57 mm x 13.18 mm) for Reverse Flow at 1200m above Sea Level for 85°C Optical with 135W Total Card Power**

Inlet Temperature to the Card (°C)	With QSFP			Without QSFP		
	Cubic Feet per Minute (CFM)	Linear Feet per Minute (LFM)	Static Pressure (inwg)	Cubic Feet per Minute (CFM)	Linear Feet per Minute (LFM)	Static Pressure (inwg)
25	12.1	814	1.32	13.9	934	0.88
30	14.0	943	1.74	16.0	1082	1.16
35	16.4	1106	2.36	18.8	1270	1.58
40	19.6	1320	3.31	22.5	1516	2.22
45	23.9	1609	4.85	27.4	1848	3.25
50	29.9	2012	7.50	34.3	2312	5.03
55	38.6	2605	12.41	44.4	2995	8.34

**Table 18: Inlet Temperature versus Airflow Requirement of PCIe Card Slot (104.57 mm x 13.18 mm) for Reverse Flow at Sea Level for 85°C Optical with 150W Total Card Power**

Inlet Temperature to the Card (°C)	With QSFP			Without QSFP		
	Cubic Feet per Minute (CFM)	Linear Feet per Minute (LFM)	Static Pressure (inwg)	Cubic Feet per Minute (CFM)	Linear Feet per Minute (LFM)	Static Pressure (inwg)
25	13.4	906	1.62	15.2	1026	1.05
30	15.5	1048	2.13	17.6	1186	1.38
35	18.2	1228	2.88	20.6	1391	1.88
40	21.7	1464	4.04	24.6	1659	2.64
45	26.4	1781	5.91	30.0	2019	3.86
50	33.0	2225	9.12	37.4	2523	5.96
55	42.7	2877	15.08	48.4	3264	9.88

**Table 19: Inlet Temperature versus Airflow Requirement of PCIe Card Slot (104.57 mm x 13.18 mm) for Reverse Flow at 1200m above Sea Level for 85°C Optical with 150W Total Card Power**

Inlet Temperature to the Card (°C)	With QSFP			Without QSFP		
	Cubic Feet per Minute (CFM)	Linear Feet per Minute (LFM)	Static Pressure (inwg)	Cubic Feet per Minute (CFM)	Linear Feet per Minute (LFM)	Static Pressure (inwg)
25	14.4	971	1.84	16.3	1099	1.20
30	16.7	1124	2.43	18.9	1273	1.58
35	19.6	1319	3.31	22.2	1494	2.15
40	23.3	1574	4.65	26.5	1783	3.03
45	28.4	1918	6.82	32.2	2174	4.46
50	35.6	2399	10.56	40.3	2720	6.91
55	46.1	3105	17.52	52.3	3522	11.48

## Regulatory Compliance Statements

## FCC Class A Products

**Note:** These devices are for use with UL Listed Servers or I.T.E.

### Safety Compliance

The following safety standards apply to all products listed above.

- EU LVD Directive 2014/35/EU
- IEC 62368-1:2014 (2nd Edition)

## EMC Compliance

The following standards apply.

### Class A Products

- FCC Part 15 – Radiated & Conducted Emissions (USA)
- CAN ICES-3(A)/NMB-3(A) – Radiated & Conducted Emissions (Canada)
- CISPR 32 – Radiated & Conducted Emissions (International)
- EN55032: 2015 – Radiated & Conducted Emissions (European Union)
- EN55035:2017 – Immunity (European Union)
- EMC Directive 2014/30/EU
- VCCI (Class A)– Radiated & Conducted Emissions (Japan)
- CNS13438 – Radiated & Conducted Emissions (Taiwan)
- CNS 15663 - RoHS (Taiwan)
- AS/NZS CISPR 32 – Radiated and Conducted Emissions (Australia/New Zealand)
- Article 58-2 of Radio Waves Act, Clause 3 (Korea)

### Regulatory Compliance Markings

When required, these products are provided with the following Product Certification Markings:

- UL Listed Accessories Mark for the USA and Canada
- CE mark
- FCC markings
- VCCI marking
- Australian C-Tick mark
- Korea MSIP mark
- Taiwan BSMI mark
- German GS mark

## FCC Class A User Information

The Class A products listed above comply with Part 15 of the FCC Rules. Operation is subject to the following two conditions:

1. This device may not cause harmful interference.
2. This device must accept any interference received, including interference that may cause undesired operation.

---

 **IMPORTANT!** *This equipment has been tested and found to comply with the limits for a Class A digital device, pursuant to Part 15 of the FCC rules. These limits are designed to provide reasonable protection against harmful interference when the equipment is operated in a commercial environment. This equipment generates, uses, and can radiate radio frequency energy and, if not installed and used in accordance with the instructions, may cause harmful interference to radio communications. Operation of this equipment in a residential area is likely to cause harmful interference, in which case the user will be required to correct the interference at his or her own expense.*

---

 **IMPORTANT!** *Cet équipement a été testé et jugé conforme à la Class A digital device, conformément à la règle 15 du standard FCC. Ces limites sont conçues pour fournir des protections contre des interférences nuisibles lorsque l'équipement est utilisé dans un environnement commercial. Cet équipement génère, utilise et peut émettre des énergies de radio-fréquence et, s'il n'est pas installé et utilisé conformément aux instructions, peut nuire aux communications radio. L'exploitation de cet équipement dans une zone résidentielle est susceptible de causer des interférences nuisibles, auquel cas l'utilisateur peut être tenu de prendre des mesures adéquates à ses propres frais.*

---

 **WICHTIG!** *Dieses Gerät wurde getestet und entspricht den Grenzwerten für digitale Geräte der Klasse A gemäß Teil 15 der FCC-Bestimmungen. Diese Grenzwerte bieten einen angemessenen Schutz gegen schädliche Interferenzen, wenn das Gerät in einer gewerblichen Umgebung betrieben wird. Dieses Gerät erzeugt und verwendet Hochfrequenzenergie und kann diese abstrahlen. Wenn es nicht gemäß den Anweisungen installiert und verwendet wird, kann dies Funkstörungen verursachen. Der Betrieb dieses Geräts in einem Wohngebiet kann schädliche Interferenzen verursachen. In diesem Fall muss der Benutzer die Interferenz auf eigene Kosten beheben.*

---

 **CAUTION!** *If the device is changed or modified without permission from Xilinx, the user may void his or her authority to operate the equipment.*

---

 **ATTENTION!** *Si l'appareil est modifié sans l'autorisation de Xilinx, l'utilisateur peut annuler son habilité à utiliser l'équipement.*

---

 **VORSICHT!** *Wenn das Gerät ohne Erlaubnis von Xilinx geändert wird, kann der Benutzer seine Berechtigung zum Betrieb des Geräts verlieren.*

---

## Canadian Compliance (Industry Canada)

CAN ICES-3(A)/NMB-3(A)

## China RoHS Compliance

- SJ/T 11363-2006, 11364-2006, and GB/T 26572-2011
- RoHS 3 directive 2015/863
- EU 2015/863

## VCCI Class A Statement

この装置は、クラス A 情報技術装置です。この装置を家庭環境で使用すると電波妨害を引き起こすことがあります。この場合には使用者が適切な対策を構ずるよう要求されることがあります。

VCCI-A

## KCC Notice Class A (Republic of Korea Only)

<p>A급 기기 (업무용 방송통신기기)</p> <p><b>CLASS A device</b> (commercial broadcasting and communication equipment)</p>	<p>이 기기는 업무용(A급)으로 전자파적합등록을 한 기기이오니 판매자 또는 사용자는 이 점을 주의하시기 바라며, 가정외의 지역에서 사용하는 것을 목적으로 합니다.</p> <p>This device has been approved by EMC registration. Distributors or users pay attention to this point. This device is usually aimed to be used in other area except at home</p>
--	---

## BSMI Class A Notice (Taiwan)

警告使用者:

此為甲類資訊技術設備，於居住環境中使用時，可能會造成射頻擾動，在此種情況下，使用者會被要求採取某些適對的對策。

## EU WEEE Logo

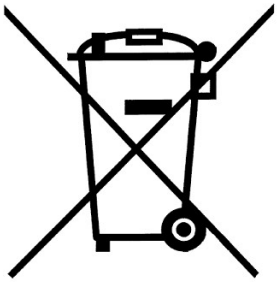

## Manufacturer Declaration European Community



### Manufacturer Declaration

Xilinx declares that the equipment described in this document is in conformance with the requirements of the European Council Directive listed below:

- Low Voltage Directive 2014/35/EU
- EMC Directive 2014/30/EU

These products follow the provisions of the European Directive 2014/53/EU.

Dette produkt er i overensstemmelse med det europæiske direktiv 2014/53/EU.

Dit product is in navolging van de bepalingen van Europees Directief 2014/53/EU.

Tämä tuote noudattaa EU-direktiivin 2014/53/EU määräyksiä.

Ce produit est conforme aux exigences de la Directive Européenne 2014/53/EU.

Dieses Produkt entspricht den Bestimmungen der Europäischen Richtlinie 2014/53/EU.

Pessi vara stenst reglugerð Evrópska Efnahags Bandalagsins númer 2014/53/EU.

Questo prodotto è conforme alla Direttiva Europea 2014/53/EU.

Dette produktet er i henhold til bestemmelsene i det europeiske direktivet 2014/53/EU.

Este produto cumpre com as normas da Diretiva Europeia 2014/53/EU.

Este producto cumple con las normas del Directivo Europeo 2014/53/EU.

Denna produkt har tillverkats i enlighet med EG-direktiv 2014/53/EU.

This declaration is based upon compliance of the Class A products listed above to the following standards:

EN 55032 (CISPR 32 Class A) RF Emissions Control.

EN 55024:2010 (CISPR 24) Immunity to Electromagnetic Disturbance.

EN 50581:2012 - Technical documentation for the assessment of electrical and electronic products with respect to the restriction of hazardous substances.

---

 **CAUTION!** *In a domestic environment, Class A products may cause radio interference, in which case the user may be required to take adequate measures.*

---

 **ATTENTION!** *Dans un environnement domestique, les produits de Classe A peuvent causer des interférences radio, auquel cas l'utilisateur peut être tenu de prendre des mesures adéquates.*

---

 **VORSICHT!** *In einer häuslichen Umgebung können Produkte der Klasse A Funkstörungen verursachen. In diesem Fall muss der Benutzer möglicherweise geeignete Maßnahmen ergreifen.*

---

## Responsible Party

Xilinx, Inc.  
 2100 Logic Drive, San Jose, CA 95124  
 United States of America  
 Phone: (408) 559-7778



## References

These documents provide supplemental material useful with this data sheet:

1. *Alveo Programming Cable User Guide* ([UG1377](#))
2. *Varium C1100 Compute Adaptor Installation Guide* (UG1525)
3. *Alveo Card Out-of-Band Management Specification for Server BMC* ([XD038](#))
4. *Card Management Solution Subsystem Product Guide* ([PG348](#))

## Revision History

The following table shows the revision history for this document.

Section	Revision Summary
<b>09/17/2021 Version 1.0</b>	
Initial release.	N/A

## Please Read: Important Legal Notices

The information disclosed to you hereunder (the "Materials") is provided solely for the selection and use of Xilinx products. To the maximum extent permitted by applicable law: (1) Materials are made available "AS IS" and with all faults, Xilinx hereby **DISCLAIMS ALL WARRANTIES AND CONDITIONS, EXPRESS, IMPLIED, OR STATUTORY, INCLUDING BUT NOT LIMITED TO WARRANTIES OF MERCHANTABILITY, NON-INFRINGEMENT, OR FITNESS FOR ANY PARTICULAR PURPOSE;** and (2) Xilinx shall not be liable (whether in contract or tort, including negligence, or under any other theory of liability) for any loss or damage of any kind or nature related to, arising under, or in connection with, the Materials (including your use of the Materials), including for any direct, indirect, special, incidental, or consequential loss or damage (including loss of data, profits, goodwill, or any type of loss or damage suffered as a result of any action brought by a third party) even if such damage or loss was reasonably foreseeable or Xilinx had been advised of the possibility of the same. Xilinx assumes no obligation to correct any errors contained in the Materials or to notify you of updates to the Materials or to product specifications. You may not reproduce, modify, distribute, or publicly display the Materials without prior written consent. Certain products are subject to the terms and conditions of Xilinx's limited warranty, please refer to Xilinx's Terms of Sale which can be viewed at <https://www.xilinx.com/legal.htm#tos>; IP cores may be subject to warranty and support terms contained in a license issued to you by Xilinx. Xilinx products are not designed or intended to be fail-safe or for use in any application requiring fail-safe performance; you assume sole risk and liability for use of Xilinx products in such critical applications, please refer to Xilinx's Terms of Sale which can be viewed at <https://www.xilinx.com/legal.htm#tos>.

## **AUTOMOTIVE APPLICATIONS DISCLAIMER**

AUTOMOTIVE PRODUCTS (IDENTIFIED AS "XA" IN THE PART NUMBER) ARE NOT WARRANTED FOR USE IN THE DEPLOYMENT OF AIRBAGS OR FOR USE IN APPLICATIONS THAT AFFECT CONTROL OF A VEHICLE ("SAFETY APPLICATION") UNLESS THERE IS A SAFETY CONCEPT OR REDUNDANCY FEATURE CONSISTENT WITH THE ISO 26262 AUTOMOTIVE SAFETY STANDARD ("SAFETY DESIGN"). CUSTOMER SHALL, PRIOR TO USING OR DISTRIBUTING ANY SYSTEMS THAT INCORPORATE PRODUCTS, THOROUGHLY TEST SUCH SYSTEMS FOR SAFETY PURPOSES. USE OF PRODUCTS IN A SAFETY APPLICATION WITHOUT A SAFETY DESIGN IS FULLY AT THE RISK OF CUSTOMER, SUBJECT ONLY TO APPLICABLE LAWS AND REGULATIONS GOVERNING LIMITATIONS ON PRODUCT LIABILITY.

## **Copyright**

© Copyright 2021 Xilinx, Inc. Xilinx, the Xilinx logo, Alveo, Artix, Kintex, Spartan, Versal, Virtex, Vivado, Zynq, and other designated brands included herein are trademarks of Xilinx in the United States and other countries. OpenCL and the OpenCL logo are trademarks of Apple Inc. used by permission by Khronos. PCI, PCIe, and PCI Express are trademarks of PCI-SIG and used under license. All other trademarks are the property of their respective owners.